

اجزای پمپ دو پروانه فنسی سری F2C

DIMENSIONS AND N.W./DIMENSIONES Y PESOS/DIMENSIONS ET POIDS/РАЗМЕРЫ И ВЕС

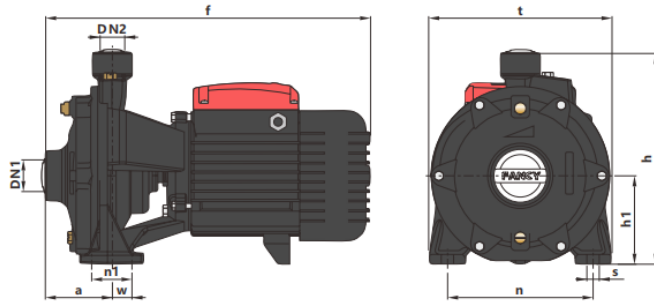

MODEL MODELO MODÈLE МОДЕЛЬ	DIMENSIONS/DIMENSIONES DIMENSIONS/РАЗМЕРЫ											GW Kg
	DN1	DN2	a	f	w	s	h	h1	n	n1	t	
F2C25/135	40	25	77	382	35	10.5	225	95	164	35	200	23
F2C25/140M	40	25	77	382	35	10.5	225	95	164	35	200	25
F2C160/160	32	25	85	413	32	10.5	268	109	185	64	231	29
F2C25/160B	40	25	85	413	32	10.5	268	109	185	64	231	29
F2C32/160B	40	32	85	413	32	10.5	268	109	185	64	231	29
F2C32/160A	40	32	85	464	32	11.5	269	112	185	64	231	36
F2C25/160A	40	25	85	464	32	11.5	269	112	185	64	231	36
F2C32/200C	40	32	85	464	32	11.5	269	112	185	64	231	39

جدول مشخصات

TECHNICAL DATA/DATOS TÉCNICOS/DONNÉES TECHNIQUES/ТЕХНИЧЕСКИЕ ДАННЫЕ

50Hz n=2900l/min

MODEL MODELO MODÈLE МОДЕЛЬ		DN mm	Power Potencia Puissance Мощность		Material	Q=Delivery/Caudal/Débit/Подача											
1-ph	3-ph		kw	hp		GPM 0	2.6	7.9	13.2	19.8	26.4	37.0	39.6	42.3	44.9	47.6	55.5
						m ³ /h 0	0.6	1.8	3	4.5	6	8.4	9	9.6	10.2	10.8	12.6
						l/min 0	10	30	50	75	100	140	150	160	170	180	210
						H=Head(m)/Altura(m)/Hauteur(m)/Общий напор в метрах водяного столба (м)											
F2Cm25/135	F2C25/135	40x25	1.1	1.5	Brass	46	45	42	39	34	29	19	16	12	-	-	-
F2Cm25/140M	F2C25/140M	40x25	1.5	2	Brass	50	49	46	42	38	33	24	22	19	16	14	-
F2Cm160/160	F2C160/160	32x25	1.5	2	Brass	52.5	52	48	44	37	30	11	-	-	-	-	-
F2Cm25/160B	F2C25/160B	40x25	1.5	2	Brass	52.5	52	49	46	41	34	18	12	-	-	-	-
F2Cm32/160B	F2C32/160B	40x32	1.5	2	Brass	52.5	52	48	45	41	36	28	25	22	-	-	-
F2Cm32/160A	F2C32/160A	40x32	2.2	3	Brass	61	60	58	55	50	45	34	30	25	20	-	-
F2Cm25/160A	F2C25/160A	40x25	2.2	3	Brass	61	60	58	55	50	45	34	30	25	20	-	-
F2Cm32/200C	F2C32/200C	40x32	3	4	Brass	66	65	62	59	56	52	44	42	40	38	36	30