

**General Purpose
Energy Efficient
Induction Motors
series 2SIE**

IE2

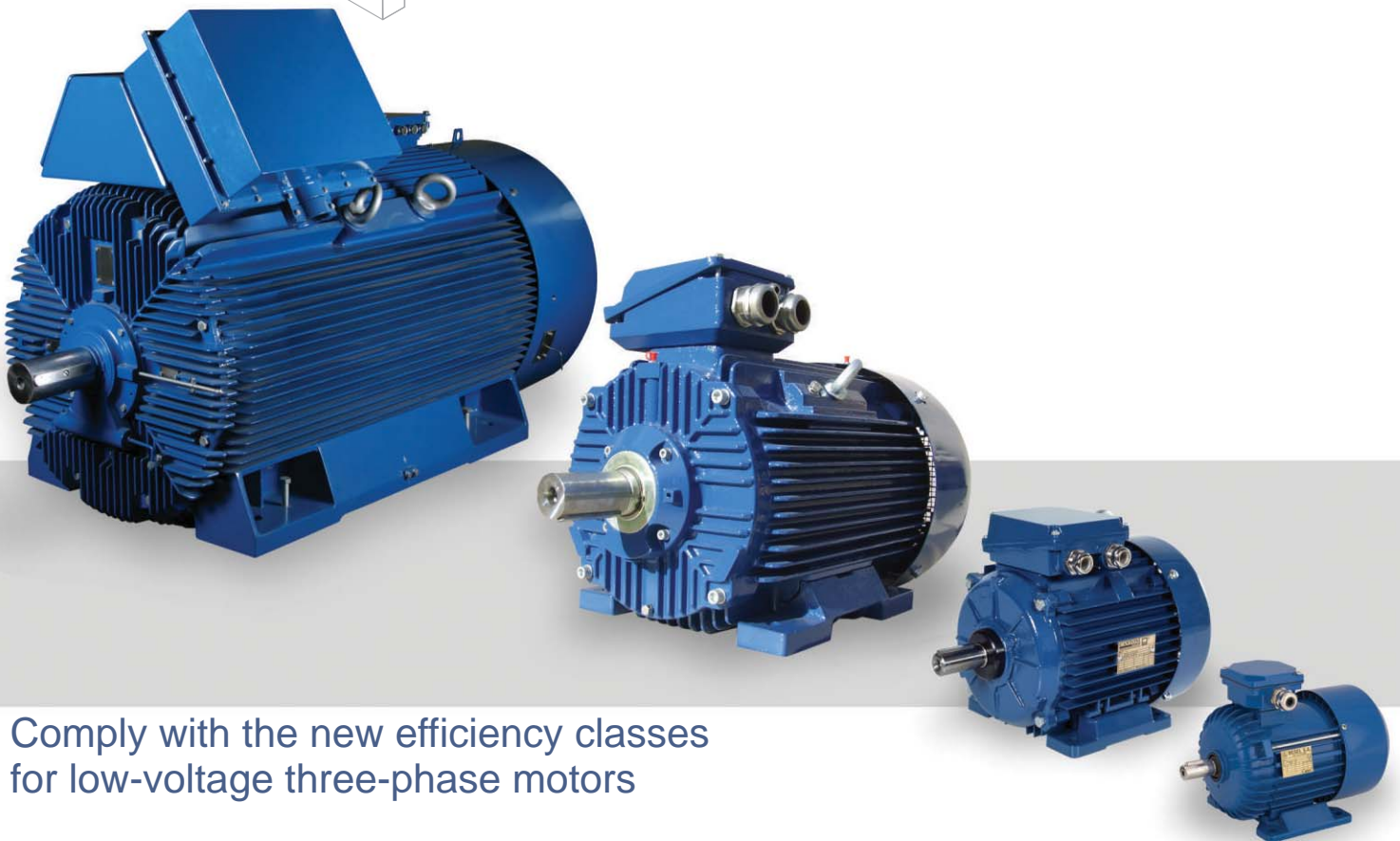

Comply with the new efficiency classes
for low-voltage three-phase motors

IEC 60034-30 standard and EU Regulation 640/2009

Product Catalogue

New efficiency classes for the low-voltage three-phase motors (IE = International Efficiency).

Along with the international discussion on energy efficiency a worldwide harmonized energy efficiency classification system has been established for low-voltage three-phase asynchronous motors.

For many years low-voltage three-phase motors in the European Union have been sold in three efficiency classes EFF3, EFF2 and EFF1. Aside from this, many different efficiency classification systems have been introduced and well-proven in many countries all over the world.

This was the reason for the International Electrotechnical Commission IEC to develop and publish an energy efficiency standard which replaces all previous national issues. In parallel IEC developed and issued a new standard for determining motor efficiency. The new standard IEC 60034-30 defines and harmonizes worldwide the efficiency classes IE1, IE2 and IE3 for low-voltage three-phase motors in the power range from 0.75 kW to 375 kW (2p=2, 4, 6):

- IE1 = Standard Efficiency
- IE2 = High Efficiency
- IE3 = Premium Efficiency

From now motors can be offered and sold with the new classes IE1, IE2 and IE3. In that case the efficiency has to be determined according to the new requirements given in the IEC 60034-2-1 standard.

According to the Commission Regulation (EC) No 640/2009 (introduced in July 2009) the required efficiency class of general-purpose motors (introduced to the market in future) will be as follows:

From 16 June 2011, motors placed for the first-time on the market shall have a minimum efficiency class of IE2.

From 1 January 2015: motors with a rated output between 7.5 - 375 kW shall have a minimum efficiency class of IE3, or IE2 if they are operated/equipped with electronic speed control (VSD).

From 1 January 2017: motors with a rated output between 0.75 - 375 kW shall have a minimum efficiency class of IE3, or IE2 if they are operated/equipped with electronic speed control (VSD).

Electronic speed control is carried out using a frequency converter (VSD) that adjusts the speed of the motor - and therefore the torque produced - based on the energy needed.

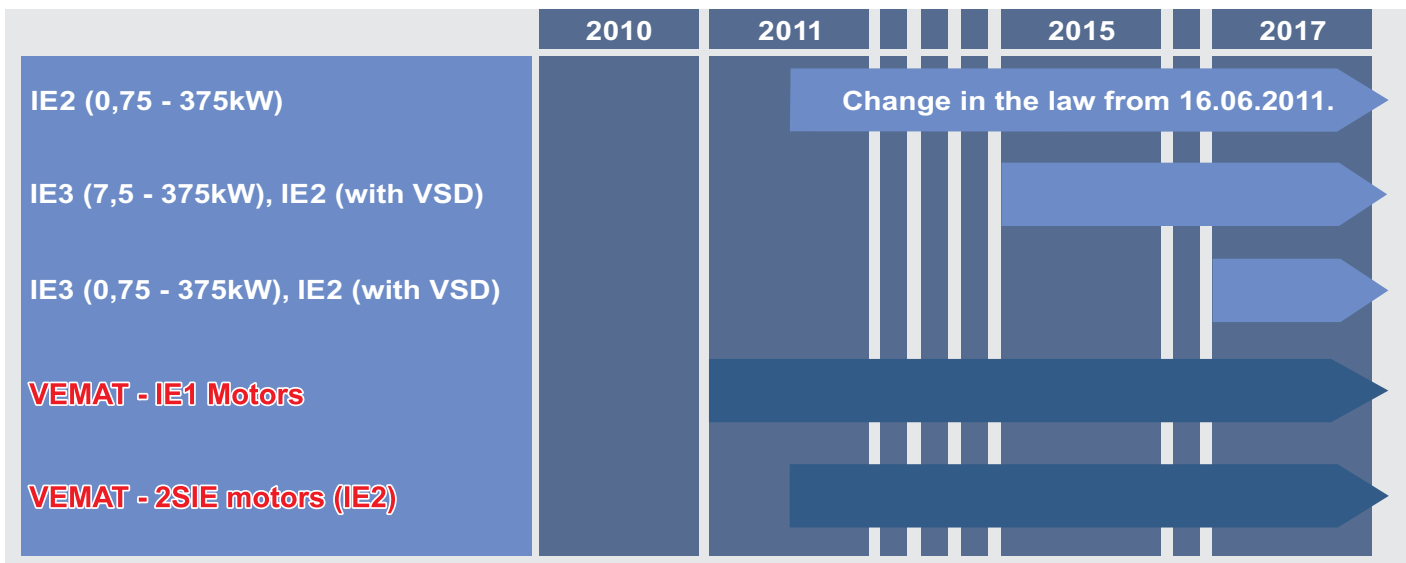

EFFICIENCY OF MOTORS

VEMAT Motori has in offer general purpose standard efficiency motors of Sg (Sh) series which fulfil IE1 class requirements according to the IEC 60034-30 standard (General Purpose 3-Phase Induction Motors Product Catalogue).

Comparison between the efficiency of VEMAT Motori (for example 2p=4) and efficiency class IE1/IE2 requirements according to the IEC 60034-30.

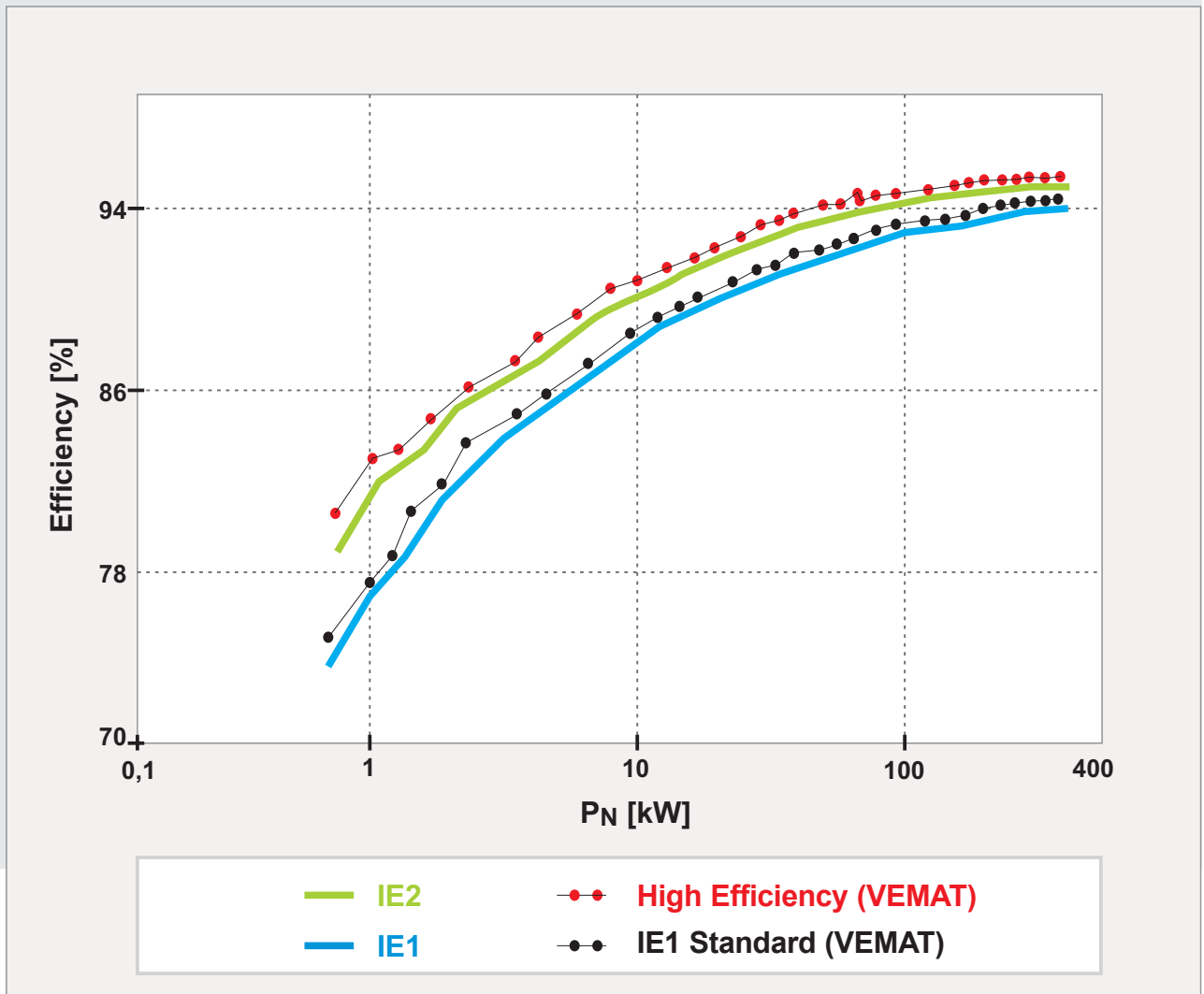

The efficiency class system specified under IEC 60034-30 is valid for low voltage three phase squirrel cage induction motors with the following specifications:

- Rated voltage up to 1,000 V
- Rated output between 0.75 kW and 375 kW
- Either 2, 4 or 6 poles
- Rated on the basis of continuous duty (S1) or intermittent periodic duty (S3) with cyclic duration factor of 80% or higher
- Capable of operating direct on-line
- Rated for operating conditions in accordance with IEC 60034-1 (temperature, installation altitude, etc.)

Motors with flanges, feet and/or shafts with mechanical dimensions different from IEC 60072-1 are also covered by this standard.

RATINGS - TOLERANCES

Permissible deviations between real values and catalogue values according to the IEC 60034-1:

| | |
|---|---|
| Power factor $\cos \varphi$ | $\Delta \cos \varphi = -1/6 (1 - \cos \varphi_N)$ |
| Efficiency η | $\Delta \eta = -15\% (100 - \eta_N)$ for $P_N \leq 150 \text{ kW}$ $\Delta \eta = -10\% (100 - \eta_N)$ for $P_N > 150 \text{ kW}$ |
| Speed n | $\Delta n = \pm 20\% (n_s - n_N)$ for $P_N > 1 \text{ kW}$ $\Delta n = \pm 30\% (n_s - n_N)$ for $P_N \leq 1 \text{ kW}$ |
| Locked rotor current I_L/I_N Locked rotor torque T_L/T_N | $\Delta(I_L/I_N) = +20\% (I_L/I_N)$ $\min(T_L/T_N) = -15\% (T_L/T_N)$ $\max(T_L/T_N) = +25\% (T_L/T_N)$ |
| Breakdown torque T_B/T_N | $\Delta(T_B/T_N) = -10\% (T_B/T_N)$ |
| Moment of inertia J [kgm ²] | $\Delta J = \pm 10\% J$ |
| Sound pressure level L_{pA} [dB] | $\Delta L_{pA} = +3 \text{ dB / A}$ |

STANDARDS

The electric motors are manufactured according to the international standards:

| | |
|---|---------------|
| Rating and performance | IEC 60034-1 |
| Methods for determining losses and efficiency | IEC 60034-2-1 |
| Classification of degrees of protection | IEC 60034-5 |
| Methods of cooling | IEC 60034-6 |
| Symbols of construction and mounting arrangements | IEC 60034-7 |
| Terminal markings and direction of rotation | IEC 60034-8 |
| Noise limits | IEC 60034-9 |
| Dimensions and output of electric machines | IEC 60072-1 |
| Vibration limits | IEC 60034-14 |

New IEC standards regarding efficiency classes (IEC 60034-30) and efficiency measurements (IEC 60034-2-1)

The resulting efficiency values differ from those obtained under the previous IEC 60034-2:1996 testing standard. It must be noted that the efficiency values are only comparable if they are obtained using the same measuring method.

EU Regulation 640/2009

Commission Regulation 640/2009, adapted on 22 July 2009, specifies the requirements regarding the ecodesign of electric motors and the use of electronic speed control (VSD).

IE1

IE2

IE3

All the motors are manufactured in Quality Assurance System consistent with ISO 9001.

ISO9001

The motors covered by the present catalogue comply with the regulations and standards effective in other countries, consistent with IEC standards.

IEC

All the motors described in the present catalogue are provided with CE mark.

CE

INSULATION CLASSIFICATION

The insulation system of an electric motor is determined by a given insulation class on the basis of its thermal resistance. This thermal resistance should be guaranteed by the entire set of electric insulating materials used in the motor insulating system.

Thermal resistance classification is related to the temperature of the hotspot in the insulation occurring during rated operating conditions of the electric motor, allowing for the highest permissible rise in average temperature.

This rise should be selected so that at the highest permissible ambient temperature, the temperature of the hotspot in insulation will not exceed the value assigned to a given thermal resistance class.

Symbols of thermal resistance classes (permissible insulation temperatures at 40°C ambient temperature)

| Symbol | Temperature [°C] |
|--------|------------------|
| A | 105 |
| E | 120 |
| B | 130 |
| F | 155 |
| H | 180 |

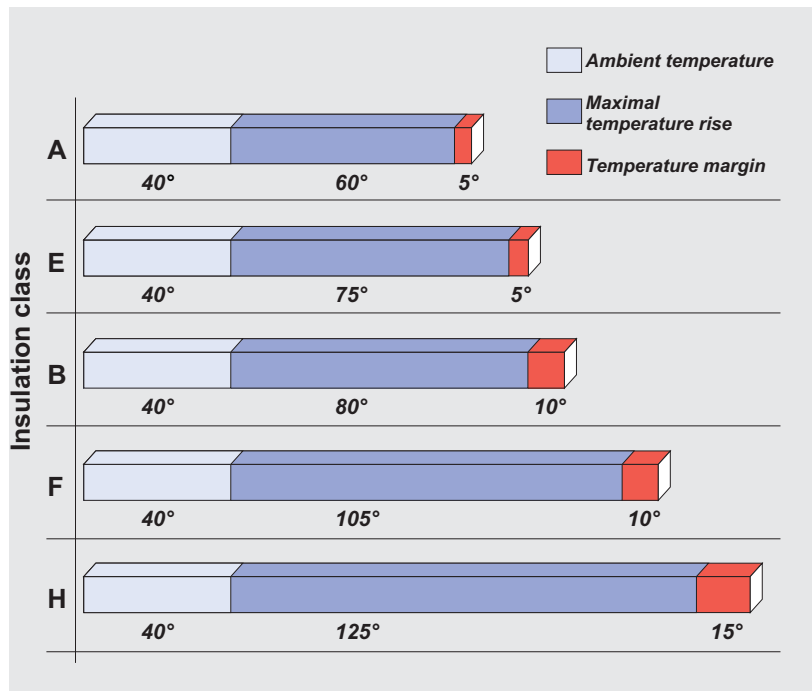

Insulation class F in an electric motor means that at ambient temperature of 40°C the temperature rise of the winding may be max. 105°C with the additional temperature margin of 10°C (under specified measuring conditions in accordance with the IEC 60034-1 standard).

Class F

The standard motors made by VEMAT Motori in their basic version have the insulation class F while the temperature rise is for class B. This means longer life for motors.

For special request we can deliver motors equipped with insulation class H.

Strengthened insulation system gives possibility to safe operation with converters.

MOTOR FEET

Motors with frame size ≤ 112 have screwed feet.
 Motors with frame size 132 have screwed feet or feet integrated with the motor housing.
 Motors with frame size 160 and 180 have feet integrated with the motor housing.
 Motors with frame size > 180 have screwed feet.
 Motors with frame size 315 have screwed feet or feet integrated with the motor housing.
 Motors with frame size 355 have feet integrated with the motor housing.

TERMINAL BOX

The terminal boxes of low voltage motors have threaded inlet holes designed for mounting cable glands. The box contains a terminal board with marked terminals making possible connection of supply cables.

In addition, terminal boxes may be provided with additional terminals connected to the ends of thermal protection or anticondensation heater circuits and extra glands to connect these circuits.

Low voltage high-power motors contain terminal boxes with cable gland seals.

The circuits of thermal protection and anticondensation heaters are connected to separate terminal boxes.

Inside the boxes there are special clamps used to ground the supply cable armouring.

VIBRATION LEVEL AND NOISE LEVEL

The rotor balancing method guarantees that a standard vibration level A is maintained in accordance with the IEC 60034-14 and a standard sound power level is maintained in accordance with the IEC 60034-9. On customer's demand the motors can be made with reduced vibration or noise level.

level A

INTERNATIONAL PROTECTION IP

According to the IEC 60034-5 standard the electric motors are provided with IP code which determines the degree of protection (ensured by the housing) against penetration of solid matter and fluids.

IP55

| PROTECTION AGAINST PENETRATION OF SOLID MATTER | | PROTECTION AGAINST PENETRATION OF FLUIDS | | MECHANICAL PROTECTION | | | |
|--|---------------|---|---|-----------------------|---|-----------------------|-------------------------|
| 1st digit | DESCRIPTION | 2nd digit | DESCRIPTION | 3rd digit | DESCRIPTION | | |
| | | | | 0 | No protection | | |
| 0 | Not protected | 0 | Not protected | 1 | Striking energy: 0.15 J | | |
| | 1 | Protected against solid bodies larger than 50 mm | 1 | | Protected against vertically falling drops of water | 2 | Striking energy: 0.20 J |
| | 2 | Protected against solid bodies larger than 12 mm | 2 | | Protected against vertically falling drops of water up to 15° | 3 | Striking energy: 0.37 J |
| | 3 | Protected against solid bodies larger than 2.5 mm | 3 | | Protected against rain up to 60° | 4 | Striking energy: 0.50 J |
| | 4 | Protected against solid bodies larger than 1 mm | 4 | | Protected against rain falling from any direction | 5 | Striking energy: 0.70 J |
| | 5 | Protected against deposition of dust | 5 | | Protected against sprayed water from any direction | 6 | Striking energy: 1 J |
| | 6 | Totally protected against deposition of dust | 6 | | Protected against temporary immersion | 7 | Striking energy: 2 J |
| | | 7 | Protected against immersion between 0.15 and 1 m | | 8 | Striking energy: 5 J | |
| | | 8 | Protected against immersion at preset pressure and time | | 9 | Striking energy: 10 J | |
| | | | | | 10 | Striking energy: 20 J | |

All VEMAT standard motors are manufactured with IP 55 degree of protection according to the standard in force (IEC 60034-5). The following table lists its characteristics.





Each size 80 to 180 motor is equipped with seal rings on the control side and on the opposite side. Labyrinth seals protect the motors from size 200 and above.

The terminal board box is sealed with a gasket.

Motors with a higher degree of protection are available on request.

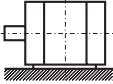
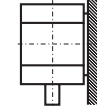
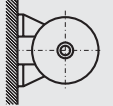
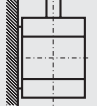
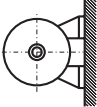
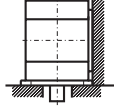
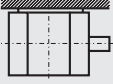
MOUNTING ARRANGEMENTS

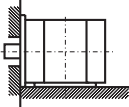
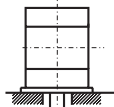
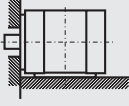
According to the IEC 60034-7 standard

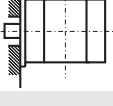
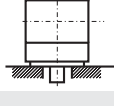
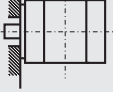
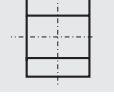
| | Horizontal shaft | | | Vertical shaft | | | |
|---|------------------|--------|--|---|-----------------------|------------|----------|
| | Designation | | Frame size | Designation | | Frame size | |
| | Code II | Code I | | Code II | Code I | | |
|  | IM 1001 | IM B3 | 80 ÷ 355 |  | IM 1011 | IM V5 | 80 ÷ 315 |
|  | IM 1051 | IM B6 | 80 ÷ 280 |  | IM 1031 | IM V6 | 80 ÷ 315 |
|  | IM 1061 | IM B7 | 80 ÷ 280 |  | IM 2011 or IM 2111 | IM V15 | 80 ÷ 355 |
|  | IM 1071 | IM B8 | 80 ÷ 280 |  | IM 2031 or IM 2131 | IM V36 | 80 ÷ 355 |
|  | IM 2001 | IM B35 | 80 ÷ 355 |  | IM 3011 | IM V1 | 80 ÷ 355 |
|  | IM 2101 | IM B34 | 80 ÷ 132 |  | IM 3031 | IM V3 | 80 ÷ 280 |
|  | IM 3001 | IM B5 | 80 ÷ 315 without 2SIEK 315 MC without 2SIEK 315 MD |  | IM 3611 | IM V18 | 80 ÷ 180 |
|  | IM 3601 | IM B14 | 80 ÷ 132 |  | IM 3631 | IM V19 | 80 ÷ 180 |

BEARINGS

| Frame size | Number of poles | Bearings | Mechanical Size | Type of construction | No. of poles, 2p | D.E. bearing | N.D.E. bearing |
|------------|-----------------|----------|-----------------|----------------------|------------------|--------------|----------------|
| 2SIE 80 | 2 ÷ 6 | 6204 2Z | 2SIE 315 ML | IM1001 (B3) | 4 ÷ 6 | 6319 C3 | 6314 C3 |
| 2SIE 90 | 2 ÷ 6 | 6205 2Z | 2SIEL 315 ML | IM2001 (B35) | 4 ÷ 6 | 6319 C3 | 6314 C3 |
| 2SIE 100 | 2 ÷ 6 | 6206 2Z | | | | | |
| 2SIE 112 | 2 ÷ 6 | 6306 2Z | | | | | |
| 2SIE 132 | 2 ÷ 6 | 6308 2Z | 2SIE 355 ML | IM1001 (B3) | 2 | 6217 C3 | 6217 C3 |
| 2SIE 160 | 2 ÷ 6 | 6309 2Z | 2SIEL 355 ML | IM2001 (B35) | 4 ÷ 6 | 6222 C3 | 6222 C3 |
| 2SIE 180 | 2 ÷ 6 | 6311 2Z | 2SIEK 355 ML | IM3011 (V1) | 4 ÷ 6 | 6322 C3 | 6322 C3 |
| 2SIE 200 | 2 ÷ 6 | 6312 C3 | | | | | |
| 2SIE 225 | 2 ÷ 6 | 6313 C3 | | | | | |
| 2SIE 250 | 2 ÷ 6 | 6315 C3 | | | | | |
| 2SIE 280 | 2 | 6315 C3 | 2SIE 355 H | IM1001 (B3) | 2 | 6217 C3 | 6217 C3 |
| 2SIE 280 | 4 ÷ 6 | 6318 C3 | 2SIEL 355 H | IM2001 (B35) | 4 ÷ 6 | 6322 C3 | 6322 C3 |
| 2SIE 315 | 2 | 6315 C3 | 2SIEK 355 H | IM3011 (V1) | 4 ÷ 6 | 6322 C3 | 6322 C3 |
| 2SIE 315 | 4 ÷ 6 | 6318 C3 | | | | | |

The bearings in basic version of motors for horizontal duty.

The bearings in basic version of motors for horizontal and vertical duty.

PERMISSIBLE LOADS ON THE SHAFT END

| Frame size | Number of poles | Horizontal operation | | Vertical operation | | | Frame size | Number of poles | Horizontal operation | | Vertical operation | | |
|-------------|-----------------|----------------------|-----------------|--------------------|----------|----------|-------------|-----------------|----------------------|-----------------|--------------------|----------|----------|
| | | | | | | | | | | | | | |
| | | $F_R(x=0)$ | $F_R(x = \max)$ | F_p | F_{a1} | F_{a2} | | | $F_R(x=0)$ | $F_R(x = \max)$ | F_p | F_{a1} | F_{a2} |
| | | [kN] | | [kN] | | | | | [kN] | | [kN] | | |
| 2SIE 80 | 2 | 0,33 | 0,27 | 0,09 | 0,06 | 0,12 | 2SIE 225 S | 4 | 4,20 | 3,40 | 3,20 | 2,50 | 4,10 |
| 2SIE 80 | 4 | 0,44 | 0,37 | 0,12 | 0,09 | 0,15 | 2SIE 225 M | 2 | 3,30 | 2,80 | 2,50 | 1,90 | 3,30 |
| 2SIE 90 | 2 | 0,68 | 0,44 | 0,68 | 0,35 | 0,38 | 2SIE 225 M | 4 | 4,10 | 3,30 | 3,20 | 2,30 | 4,20 |
| 2SIE 90 | 4 | 0,78 | 0,44 | 0,78 | 0,35 | 0,38 | 2SIE 225 M | 6 | 4,70 | 3,80 | 4,00 | 3,00 | 5,30 |
| 2SIE 90 | 6 | 0,96 | 0,44 | 0,96 | 0,35 | 0,38 | 2SIE 250 M | 2 | 4,10 | 3,40 | 3,10 | 2,30 | 4,10 |
| 2SIE 100 | 2 | 0,88 | 0,46 | 0,90 | 0,28 | 0,40 | 2SIE 250 M | 4 | 5,20 | 4,30 | 3,90 | 2,90 | 5,20 |
| 2SIE 100 | 4 | 1,06 | 0,46 | 0,98 | 0,38 | 0,40 | 2SIE 250 M | 6 | 5,60 | 4,60 | 5,00 | 3,60 | 6,70 |
| 2SIE 100 | 6 | 1,20 | 0,46 | 1,10 | 0,38 | 0,40 | 2SIE 280 S | 2 | 3,90 | 3,30 | 3,10 | 2,00 | 4,40 |
| 2SIE 112 | 2 | 1,00 | 0,48 | 1,00 | 0,40 | 0,45 | 2SIE 280 S | 4 | 6,70 | 5,70 | 5,00 | 3,60 | 6,80 |
| 2SIE 112 | 4 | 1,45 | 0,48 | 1,40 | 0,40 | 0,45 | 2SIE 280 S | 6 | 7,70 | 6,60 | 5,80 | 4,20 | 7,70 |
| 2SIE 112 | 6 | 1,62 | 0,48 | 1,60 | 0,40 | 0,45 | 2SIE 280 M | 2 | 3,80 | 3,20 | 3,00 | 1,90 | 4,50 |
| 2SIE 132 | 2 | 1,82 | 0,66 | 1,90 | 0,43 | 0,60 | 2SIE 280 M | 4 | 6,50 | 5,50 | 4,90 | 3,40 | 6,90 |
| 2SIE 132 | 4 | 2,10 | 0,66 | 2,20 | 0,45 | 0,60 | 2SIE 280 M | 6 | 7,40 | 6,30 | 5,70 | 3,90 | 7,90 |
| 2SIE 132 | 6 | 2,80 | 0,66 | 2,80 | 0,50 | 0,60 | 2SIE 315 S | 2 | 3,60 | 3,10 | 3,00 | 1,60 | 4,70 |
| 2SIE 160 | 2 | 2,22 | 0,98 | 2,30 | 0,92 | 0,95 | 2SIE 315 S | 4 | 6,20 | 5,20 | 4,90 | 3,10 | 7,20 |
| 2SIE 160 | 4 | 2,40 | 0,98 | 2,40 | 0,92 | 0,95 | 2SIE 315 S | 6 | 7,00 | 5,90 | 5,60 | 3,80 | 7,80 |
| 2SIE 160 | 6 | 2,85 | 1,10 | 2,90 | 0,98 | 1,00 | 2SIE 315 MA | 2 | 3,30 | 2,80 | 2,90 | 1,40 | 4,80 |
| 2SIE 180 | 2 | 2,92 | 1,30 | 3,00 | 1,10 | 1,20 | 2SIE 315 MB | 2 | 2,90 | 2,50 | 2,80 | 1,10 | 5,00 |
| 2SIE 180 | 4 | 3,60 | 1,30 | 3,60 | 1,10 | 1,30 | 2SIE 315 MA | 4 | 5,80 | 4,80 | 4,70 | 2,70 | 7,30 |
| 2SIE 180 | 6 | 4,00 | 1,80 | 4,10 | 1,40 | 1,70 | 2SIE 315 MB | 4 | 5,40 | 4,50 | 4,60 | 2,40 | 7,50 |
| 2SIE 200 LA | 2 | 3,00 | 2,50 | 2,30 | 1,80 | 2,90 | 2SIE 315 MA | 6 | 6,20 | 5,20 | 5,30 | 2,70 | 8,70 |
| 2SIE 200 LB | 2 | 3,00 | 2,50 | 2,30 | 1,80 | 2,90 | 2SIE 315 MB | 6 | 5,60 | 4,80 | 5,20 | 2,00 | 9,20 |
| 2SIE 200 L | 4 | 3,70 | 3,10 | 2,80 | 2,00 | 3,90 | 2SIE 315MC | 2 | 2,40 | 2,10 | 2,40 | 0,40 | 5,00 |
| 2SIE 200 LA | 6 | 4,30 | 3,60 | 3,60 | 2,90 | 4,60 | 2SIE 315MC | 4 | 6,50 | 5,50 | 5,60 | 3,00 | 9,00 |
| 2SIE 200 LB | 6 | 4,20 | 3,50 | 3,60 | 2,80 | 4,60 | 2SIE 315MC | 6 | 7,50 | 6,30 | 6,40 | 3,30 | 10,50 |
| | | | | | | | 2SIE 315MD | 6 | 7,50 | 6,30 | 6,40 | 3,30 | 10,50 |

VERSION WITH ROLLER BEARINGS for motors 315 and 355

| Mechanical Size | Type of construction | No. of poles, 2p | D.E. bearing | N.D.E. bearing |
|-----------------|----------------------|------------------|--------------|----------------|
| 2SIE 315 ML | IM1001 (B3) | 4 ÷ 6 | NU319 EM1C3 | 6314 C3 |
| 2SIE 355 ML | IM1001 (B3) | 4 ÷ 6 | NU222 EM1C3 | 6222 C3 |
| 2SIE 355 H | IM1001 (B3) | 4 ÷ 6 | NU322 EM1C3 | 6322 C3 |

| Motor type | Number of poles | Length of shaft extension E(mm) | Horizontal mounting | | | Vertical operation |
|-------------|-----------------|---------------------------------|---------------------------|-------|--------------------------|--------------------|
| | | | Permissible radial forces | | Permissible axial forces | |
| | | | FX0 | FXmax | FA | |
| 2SIE 315 ML | 4 | 170 | 27 | 13 | 3,5 | on request |
| | 6 | 170 | 29 | 13 | 4 | on request |
| 2SIE 355 ML | 4 | 210 | 22 | 19 | 5 | on request |
| | 6 | 210 | 23 | 19 | 5,5 | on request |
| 2SIE 355 H | 4 | 210 | 27 | 17 | 6 | on request |
| | 6 | 210 | 29 | 15 | 7 | on request |

Value of radial force F_R acting on the shaft end for a given belt pulley diameter is calculated according to the following formula:

$$F_R = \frac{19600 \times P \times k}{D_K \times n} \text{ [N]}$$

where: P - motor output [kW]
 D_K - belt pulley diameter [m]
 n - speed [rpm]
 k - belt tension factor:
 for V-belts $k=2,2$
 for flat belts $k=3$

Value of force F_R acting on any point of the shaft end (between points $X=\max$ and $X=0$) may be calculated according to the following formula:

$$F_R = F_{X0} - \frac{X}{E} \times (F_{X0} - F_{XMAX}) \text{ [N]}$$

where: F_{X0} - value of F_R force acting on the beginning of the shaft end
 F_{XMAX} - value of F_R force acting on the end of the shaft end
 E - length of the shaft end

HOUSING, END SHIELDS, FEET

| Frame size [mm] | Motor housing | End shields | Feet |
|-----------------|---------------|-------------|-----------------------------------|
| 80 | Aluminium | Aluminium | Aluminium - screwed |
| 90 | Aluminium | Aluminium | Aluminium - screwed |
| 100 | Aluminium | Aluminium | Aluminium - screwed |
| 112 | Aluminium | Cast iron | Aluminium - screwed |
| 132 | Cast iron | Cast iron | Cast iron - screwed |
| 160 | Cast iron | Cast iron | Cast iron - integrated |
| 180 | Cast iron | Cast iron | Cast iron - integrated |
| 200 | Cast iron | Cast iron | Cast iron - screwed |
| 225 | Cast iron | Cast iron | Cast iron - screwed |
| 250 | Cast iron | Cast iron | Cast iron - screwed |
| 280 | Cast iron | Cast iron | Cast iron - screwed |
| 315 | Cast iron | Cast iron | Cast iron - screwed or integrated |
| 355 | Cast iron | Cast iron | Cast iron - integrated |

In motors of frame size 80, 90 and 100: on request end shields may be made of cast iron.

In motors of frame size 132: feet may be integrated with housing.

Motor housing

aluminium

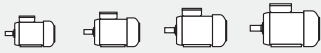

80 90 100 112

 aluminium  cast iron

cast iron

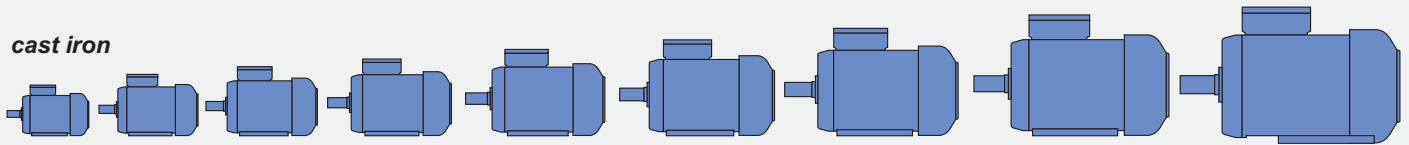

132 160 180 200 225 250 280 315 355

Other specifications dependent on the frame size:

| Frame size | Degree of protection | Position of the terminal box | Number of terminals | Number of cable outlets | Optional rotation of the terminal box | Glands | Temperature sensors in winding | Bearing lubrication on the run | Thermal protection of bearings |
|------------|----------------------|------------------------------|---------------------|-------------------------|---------------------------------------|--------|--------------------------------|--------------------------------|--------------------------------|
| 80 | IP 55 | top | 6 | 1 | 180° | M 20 | on request | no | no |
| 90 | IP 55 | top | 6 | 2 | 180° | M 20 | on request | no | no |
| 100 | IP 55 | top | 6 | 2 | 180° | M 20 | on request | no | no |
| 112 | IP 55 | top | 6 | 2 | 180° | M 25 | on request | no | no |
| 132 | IP 55 | top | 6 | 2 | 180° | M 25 | on request | no | no |
| 160 | IP 55 | top | 6 | 2 | 180° | M 40 | on request | on request | on request |
| 180 | IP 55 | top | 6 | 2 | 180° | M 40 | on request | on request | on request |
| 200 | IP 55 | top | 6 | 2 | 4 × 90° | M 50 | PTC | yes | on request |
| 225 | IP 55 | top | 6 | 2 | 4 × 90° | M 50 | PTC | yes | on request |
| 250 | IP 55 | top | 6 | 2 | 4 × 90° | M 63 | PTC | yes | on request |
| 280 | IP 55 | top | 6 | 2 | 4 × 90° | M 63 | PTC | yes | on request |
| 315 | IP 55 | top | 6 | 2 | 4 × 90° | M 76 | PTC | yes | on request |
| 355ML | IP 55 | top | 6 | 2 | 4 × 90° | M 76 | PTC Mark A | yes | on request |
| 355H | IP 55 | top | 6 | 2 | 4 × 90° | M 90 | Pt 100 | yes | Pt 100 |

DESCRIPTION OF THE CATALOGUE VERSION

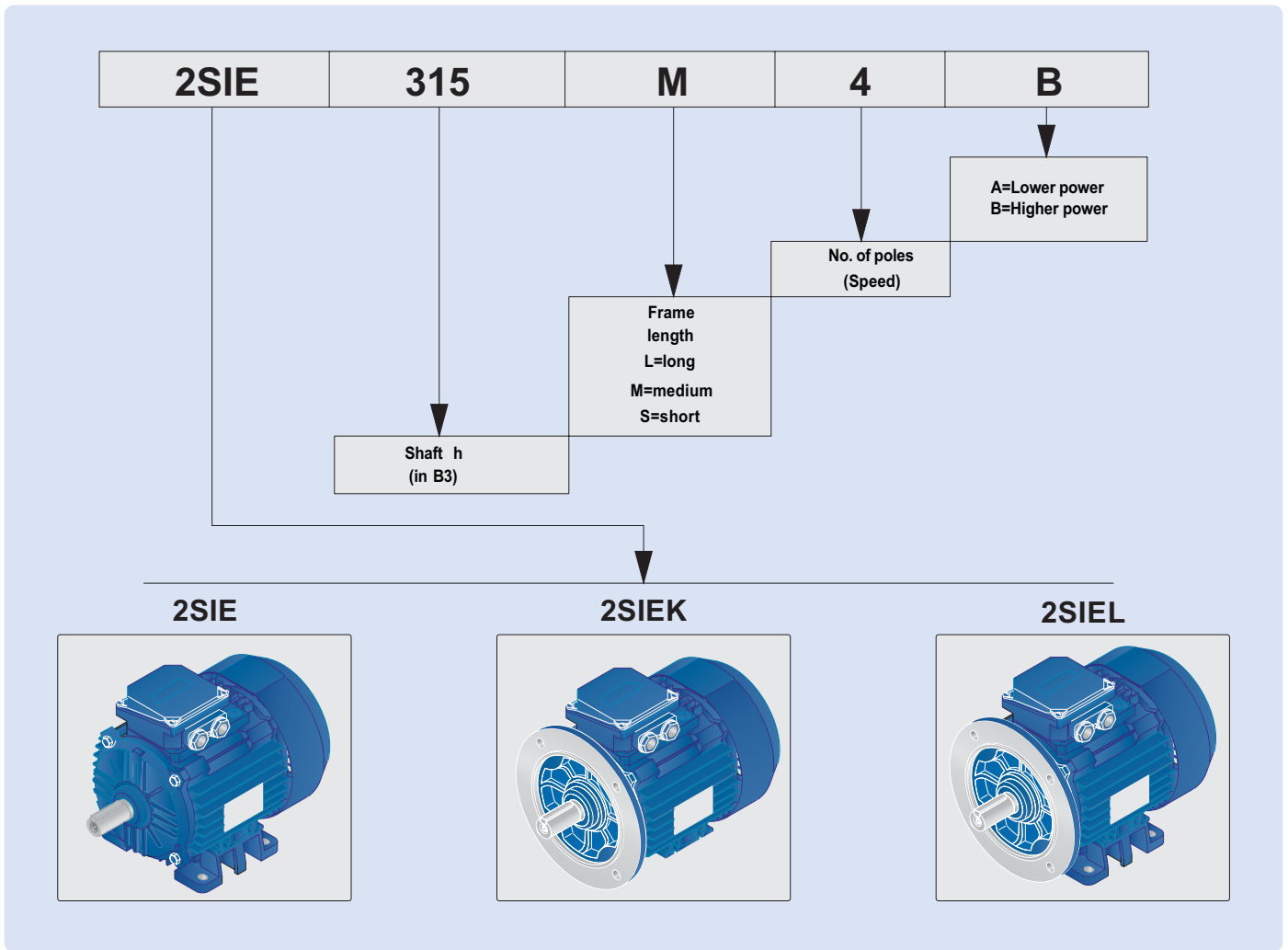

ORDERING INFORMATION

Orders for motors should specify:

- motor type designation,
- rated output,
- rated speed,
- operating duty,
- supply voltage and connection,
- frequency,
- mounting arrangements, end shield material,
- degree of protection,
- type of machine driven,
- other details of regarding special requests,

and information concerning additional accessories e.g.

- thermal protection,
- anticondensation heaters,
- vibration sensors,
- etc.

When ordering high-power or special purpose motors one should also indicate:

- required direction of rotation,
- required degree of interior protection,
- method of start-up,
- method of coupling with the driven unit (gears, dimensions of belt pulleys, etc.),
- type of machine driven (nature of load), including the moment of inertia J or flywheel effect GD^2 brought to the motor shaft,
- other customer's specifications.

When ordering spare parts one should specify:

- full designation of the motor type including its serial number (provided on the nameplate) or catalogue number,
- degree of protection,
- mounting arrangement,
- name of part,
- number of pieces.

As part of our development program, we reserve the right to alter or amend any of the specifications without giving prior notice

HIGH EFFICIENCY IE2

TECHNICAL DATA

| Item | Type | Rated output | | Rated speed n_N [min ⁻¹] | Rated torque T_N [Nm] | Efficiency | | | Power factor $\cos \varphi_N$ [-] | Full load current | | | Locked rotor torque T_L/T_N [-] | Locked rotor current I_L/I_N [-] | Breakdown torque T_B/T_N [-] | Moment of Inertia J [kgm ²] | Weight [kg] |
|---|--------------|--------------|------|--|-------------------------------|--------------|----------------------------|----------------------------|---|----------------------------|------|------|---|--|--------------------------------------|---|----------------|
| | | P_N | | | | η_N [%] | I_N at rated voltage [A] | I_N at rated voltage [A] | | I_N at rated voltage [A] | | | | | | | |
| | | [kW] | [HP] | | | | | | | | 50% | 75% | | | | | |
| 2p=2 n_s=3000 rpm f=50Hz | | | | | | | | | | | | | | | | | |
| 1 | 2SIE 80-2A | 0,75 | 1 | 2840 | 2,52 | 72,0 | 76,5 | 79,0 | 0,74 | 3,3 | 2,0 | 1,9 | 3,2 | 5,0 | 3,0 | 0,0008 | 8,5 |
| 2 | 2SIE 80-2B | 1,1 | 1,5 | 2840 | 3,7 | 77,0 | 80,0 | 80,0 | 0,75 | 4,8 | 2,8 | 2,7 | 3,4 | 5,5 | 3,4 | 0,0011 | 9,8 |
| 3 | 2SIE 90S2 | 1,5 | 2 | 2880 | 5 | 80,0 | 82,0 | 81,8 | 0,81 | 5,7 | 3,5 | 3,3 | 3,3 | 7,6 | 3,4 | 0,0014 | 13,9 |
| 4 | 2SIE 90L2 | 2,2 | 3 | 2870 | 7,3 | 83,4 | 84,4 | 83,5 | 0,81 | 8,2 | 4,9 | 4,7 | 3,7 | 7,3 | 3,7 | 0,0016 | 17,3 |
| 5 | 2SIE 100L2 | 3 | 4 | 2915 | 9,8 | 82,8 | 84,7 | 84,6 | 0,83 | 10,7 | 6,5 | 6,2 | 3,1 | 8,3 | 3,3 | 0,0039 | 26,7 |
| 6 | 2SIE 112M2 | 4 | 5,5 | 2915 | 13,1 | 86,9 | 87,3 | 86,3 | 0,87 | 13,4 | 8,1 | 7,7 | 2,4 | 8,5 | 2,7 | 0,006 | 33,5 |
| 7 | 2SIE 132S2A | 5,5 | 7,5 | 2930 | 17,9 | 88,5 | 89,2 | 87,5 | 0,90 | 17,5 | 10,6 | 10,1 | 2,7 | 8,8 | 3,4 | 0,014 | 59,5 |
| 8 | 2SIE 132S2B | 7,5 | 10 | 2920 | 24,5 | 88,2 | 89,1 | 88,6 | 0,92 | 23,1 | 13,9 | 13,2 | 2,7 | 8,5 | 3,3 | 0,017 | 70,8 |
| 9 | 2SIE 160M2A | 11 | 15 | 2940 | 35,7 | 89,4 | 90,3 | 90,0 | 0,87 | 35,3 | 21,4 | 20,3 | 2,0 | 7,2 | 2,7 | 0,042 | 96 |
| 10 | 2SIE 160M2B | 15 | 20 | 2935 | 48,8 | 90,6 | 91,0 | 90,3 | 0,89 | 46,9 | 28,3 | 26,9 | 2,0 | 7,0 | 2,8 | 0,048 | 103 |
| 11 | 2SIE 160L2 | 18,5 | 25 | 2935 | 60,2 | 92,2 | 92,3 | 91,5 | 0,91 | 55,8 | 33,8 | 32,1 | 2,3 | 7,7 | 2,9 | 0,059 | 118 |
| 12 | 2SIE 180M2 | 22 | 30 | 2945 | 71,3 | 90,8 | 91,7 | 91,3 | 0,88 | 68,7 | 41,6 | 39,5 | 2,6 | 7,5 | 3,2 | 0,062 | 156 |
| 13 | 2SIE 200L2A | 30 | 40 | 2952 | 97 | 92,0 | 92,7 | 92,3 | 0,90 | 91 | 55 | 52 | 2,0 | 6,3 | 2,6 | 0,15 | 265 |
| 14 | 2SIE 200L2B | 37 | 50 | 2954 | 120 | 93,6 | 93,5 | 92,7 | 0,91 | 110 | 66 | 63 | 1,8 | 6,0 | 2,5 | 0,18 | 283 |
| 15 | 2SIE 225M2 | 45 | 60 | 2967 | 145 | 93,2 | 93,6 | 93,1 | 0,90 | 135 | 82 | 78 | 1,5 | 6,2 | 2,8 | 0,26 | 380 |
| 16 | 2SIE 250M2 | 55 | 75 | 2959 | 177 | 93,8 | 93,9 | 93,3 | 0,91 | 163 | 98 | 94 | 1,8 | 5,7 | 2,3 | 0,42 | 492 |
| 17 | 2SIE 280S2 | 75 | 100 | 2978 | 241 | 94,0 | 94,4 | 94,1 | 0,91 | 220 | 133 | 127 | 1,5 | 6,9 | 2,9 | 0,76 | 655 |
| 18 | 2SIE 280M2 | 90 | 125 | 2972 | 289 | 93,4 | 94,2 | 94,2 | 0,91 | 264 | 160 | 152 | 1,5 | 6,5 | 2,4 | 0,95 | 688 |
| 19 | 2SIE 315S2 | 110 | 150 | 2978 | 353 | 94,1 | 94,7 | 94,5 | 0,92 | 318 | 193 | 183 | 1,7 | 7,0 | 2,9 | 0,98 | 883 |
| 20 | 2SIE 315M2A | 132 | 175 | 2979 | 423 | 94,5 | 95,0 | 94,8 | 0,92 | 379 | 229 | 218 | 1,9 | 7,5 | 3,1 | 1,15 | 950 |
| 21 | 2SIE 315M2B | 160 | 220 | 2975 | 514 | 95,1 | 95,3 | 94,9 | 0,93 | 453 | 274 | 261 | 1,8 | 6,6 | 2,7 | 1,40 | 1037 |
| 22 | 2SIE 315M2C | 200 | 270 | 2979 | 641 | 95,3 | 95,6 | 95,3 | 0,93 | - | 342 | 325 | 2,2 | 7,7 | 3,0 | 1,74 | 1111 |
| 23 | 2SIE 355ML2 | 200 | 270 | 2987 | 639 | 94,0 | 95,2 | 95,6 | 0,90 | - | 353 | 336 | 1,9 | 8,0 | 3,4 | 2,8 | 1600 |
| 24 | 2SIE 355ML2A | 250 | 340 | 2982 | 801 | 94,7 | 95,6 | 95,7 | 0,91 | - | 435 | 414 | 1,8 | 7,0 | 2,8 | 2,8 | 1600 |
| 25 | 2SIE 355ML2B | 315 | 430 | 2982 | 1009 | 95,0 | 95,7 | 95,7 | 0,91 | - | 548 | 522 | 1,9 | 7,3 | 3,0 | 3,0 | 1680 |
| 26 | 2SIE 355H2D | 355 | 480 | 2985 | 1136 | 94,7 | 95,5 | 95,7 | 0,91 | - | 617 | 588 | 1,7 | 7,4 | 2,7 | 4,9 | 2140 |
| 2p=4 n_s=1500 rpm f=50Hz | | | | | | | | | | | | | | | | | |
| 27 | 2SIE 80-4B | 0,75 | 1 | 1400 | 5,12 | 70,0 | 77,0 | 80,0 | 0,65 | 3,7 | 2,3 | 2,2 | 3,1 | 4,2 | 3,2 | 0,00209 | 9,6 |
| 28 | 2SIE 90S4 | 1,1 | 1,5 | 1425 | 7,4 | 79,1 | 81,3 | 81,4 | 0,76 | 4,5 | 2,7 | 2,6 | 2,7 | 6,1 | 3,2 | 0,0031 | 16,3 |
| 29 | 2SIE 90L4 | 1,5 | 2 | 1425 | 10,1 | 81,2 | 83,2 | 82,8 | 0,76 | 6,0 | 3,6 | 3,4 | 2,8 | 6,4 | 3,3 | 0,0036 | 19 |
| 30 | 2SIE 100L4A | 2,2 | 3 | 1440 | 14,6 | 84,6 | 85,5 | 84,7 | 0,83 | 7,9 | 4,7 | 4,5 | 2,4 | 7,3 | 2,8 | 0,007 | 25,5 |
| 31 | 2SIE 100L4B | 3 | 4 | 1445 | 19,8 | 84,3 | 86,1 | 86,0 | 0,76 | 11,5 | 6,9 | 6,6 | 3,4 | 8,0 | 3,6 | 0,0077 | 30 |
| 32 | 2SIE 112M4 | 4 | 5,5 | 1450 | 26,3 | 86,9 | 87,7 | 87,0 | 0,79 | 14,6 | 8,8 | 8,4 | 2,0 | 6,7 | 2,9 | 0,0115 | 35,5 |
| 33 | 2SIE 132S4 | 5,5 | 7,5 | 1460 | 36 | 87,0 | 88,2 | 88,0 | 0,80 | 19,6 | 11,9 | 11,3 | 2,5 | 7,9 | 3,2 | 0,031 | 69 |
| 34 | 2SIE 132M4 | 7,5 | 10 | 1460 | 49,1 | 88,5 | 89,2 | 88,7 | 0,80 | 26,5 | 16,1 | 15,3 | 2,4 | 7,5 | 3,3 | 0,036 | 73,5 |
| 35 | 2SIE 160M4 | 11 | 15 | 1470 | 71,5 | 89,3 | 90,3 | 89,8 | 0,81 | 38,0 | 22,9 | 21,8 | 2,0 | 7,1 | 2,8 | 0,057 | 106 |
| 36 | 2SIE 160L4 | 15 | 20 | 1470 | 97,4 | 90,7 | 91,3 | 90,6 | 0,81 | 51,3 | 31,1 | 29,5 | 2,1 | 7,3 | 3,0 | 0,07 | 126 |
| 37 | 2SIE 180M4 | 18,5 | 25 | 1470 | 120,2 | 90,2 | 91,3 | 91,2 | 0,86 | 59,2 | 35,8 | 34,0 | 2,8 | 7,5 | 3,0 | 0,139 | 169 |
| 38 | 2SIE 180L4 | 22 | 30 | 1460 | 143,9 | 91,4 | 92,0 | 91,6 | 0,86 | 70,1 | 42,4 | 40,3 | 2,8 | 7,3 | 2,9 | 0,144 | 180 |
| 39 | 2SIE 200L4 | 30 | 40 | 1474 | 194 | 93,0 | 93,1 | 92,4 | 0,87 | 93 | 56 | 54 | 1,9 | 5,6 | 2,3 | 0,31 | 285 |
| 40 | 2SIE 225S4 | 37 | 50 | 1484 | 238 | 92,9 | 93,5 | 93,2 | 0,85 | 117 | 71 | 67 | 2,0 | 7,0 | 2,7 | 0,49 | 368 |
| 41 | 2SIE 225M4 | 45 | 60 | 1485 | 289 | 93,0 | 93,8 | 93,6 | 0,84 | 144 | 87 | 83 | 2,1 | 7,6 | 2,8 | 0,55 | 395 |
| 42 | 2SIE 250M4 | 55 | 75 | 1479 | 355 | 93,0 | 93,9 | 93,5 | 0,90 | 164 | 99 | 94 | 1,8 | 6,0 | 2,1 | 0,79 | 478 |
| 43 | 2SIE 280S4 | 75 | 100 | 1489 | 481 | 94,1 | 94,6 | 94,2 | 0,89 | 225 | 136 | 129 | 2,0 | 7,0 | 2,5 | 1,37 | 678 |
| 44 | 2SIE 280M4 | 90 | 125 | 1486 | 578 | 94,5 | 94,7 | 94,3 | 0,88 | 272 | 165 | 157 | 1,7 | 6,2 | 2,2 | 1,50 | 700 |

FOOT MOUNTED MOTORS - IM B3



DIMENSIONAL DRAWINGS

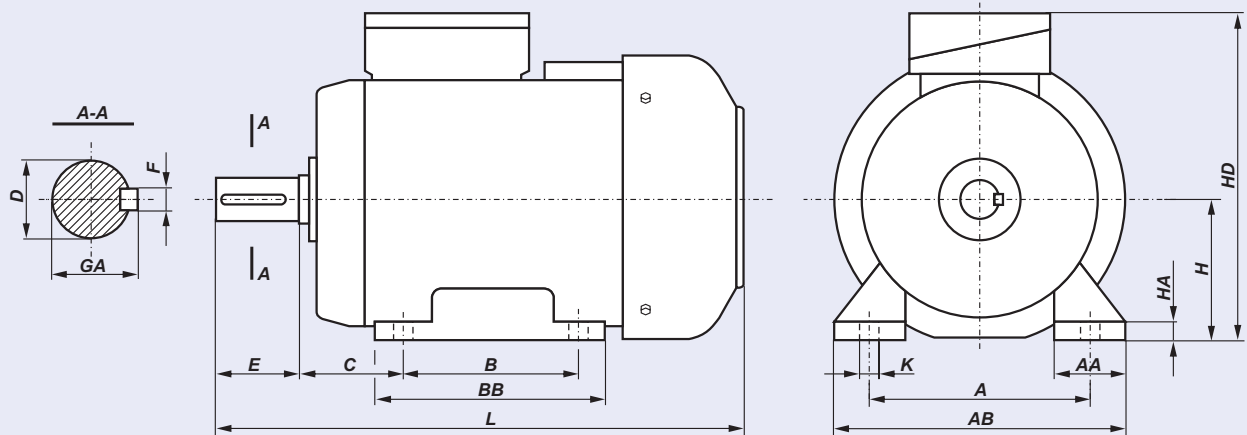

| Motor type | A | B | C | D | E | F | GA | H | K | AA | AB | BB | HA | HD | L |
|---------------------|-----|-----|-----|------|-----|------|------|-----|----|----|-----|-----|----|-----|-----|
| 2SIE 80-A | 125 | 100 | 50 | 19j6 | 40 | 6h9 | 21,5 | 80 | 10 | 55 | 160 | 130 | 9 | 200 | 266 |
| 2SIE 80-B | 125 | 100 | 50 | 19j6 | 40 | 6h9 | 21,5 | 80 | 10 | 55 | 160 | 130 | 9 | 200 | 278 |
| 2SIE 90S-2,4,6 | 140 | 100 | 56 | 24j6 | 50 | 8h9 | 27 | 90 | 10 | 50 | 170 | 153 | 10 | 220 | 330 |
| 2SIE 90L-2 | 140 | 125 | 56 | 24j6 | 50 | 8h9 | 27 | 90 | 10 | 50 | 170 | 153 | 10 | 220 | 330 |
| 2SIE 90L-4,6 | 140 | 125 | 56 | 24j6 | 50 | 8h9 | 27 | 90 | 10 | 50 | 170 | 153 | 10 | 220 | 355 |
| 2SIE 100L-2, 4A | 160 | 140 | 63 | 28j6 | 60 | 8h9 | 31 | 100 | 12 | 45 | 200 | 172 | 14 | 240 | 420 |
| 2SIE 100L-4B | 160 | 140 | 63 | 28j6 | 60 | 8h9 | 31 | 100 | 12 | 45 | 200 | 172 | 14 | 240 | 440 |
| 2SIE 100L-6 | 160 | 140 | 63 | 28j6 | 60 | 8h9 | 31 | 100 | 12 | 45 | 200 | 172 | 14 | 240 | 376 |
| 2SIE 112M-2,6 | 190 | 140 | 70 | 28j6 | 60 | 8h9 | 31 | 112 | 12 | 54 | 230 | 174 | 14 | 276 | 384 |
| 2SIE 112M-4 | 190 | 140 | 70 | 28j6 | 60 | 8h9 | 31 | 112 | 12 | 54 | 230 | 174 | 14 | 276 | 411 |
| 2SIE 132S-2B,6 | 216 | 140 | 89 | 38k6 | 80 | 10h9 | 41 | 132 | 12 | 56 | 278 | 182 | 16 | 310 | 463 |
| 2SIE 132S-2B,4 | 216 | 140 | 89 | 38k6 | 80 | 10h9 | 41 | 132 | 12 | 56 | 278 | 220 | 16 | 310 | 501 |
| 2SIE 132M-4,6A,6B | 216 | 178 | 89 | 38k6 | 80 | 10h9 | 41 | 132 | 12 | 56 | 278 | 220 | 16 | 310 | 501 |
| 2SIE 160M-2A,2B,4,6 | 254 | 210 | 108 | 42k6 | 110 | 12h9 | 45 | 160 | 15 | 60 | 305 | 256 | 20 | 370 | 612 |
| 2SIE 160L-2,4,6 | 254 | 254 | 108 | 42k6 | 110 | 12h9 | 45 | 160 | 15 | 60 | 305 | 300 | 20 | 370 | 656 |
| 2SIE 180M-2,4 | 279 | 241 | 121 | 48k6 | 110 | 14h9 | 51,5 | 180 | 15 | 70 | 350 | 320 | 26 | 408 | 705 |
| 2SIE 180L-4,6 | 279 | 279 | 121 | 48k6 | 110 | 14h9 | 51,5 | 180 | 15 | 70 | 350 | 320 | 26 | 408 | 705 |

FOOT MOUNTED MOTORS - IM B3

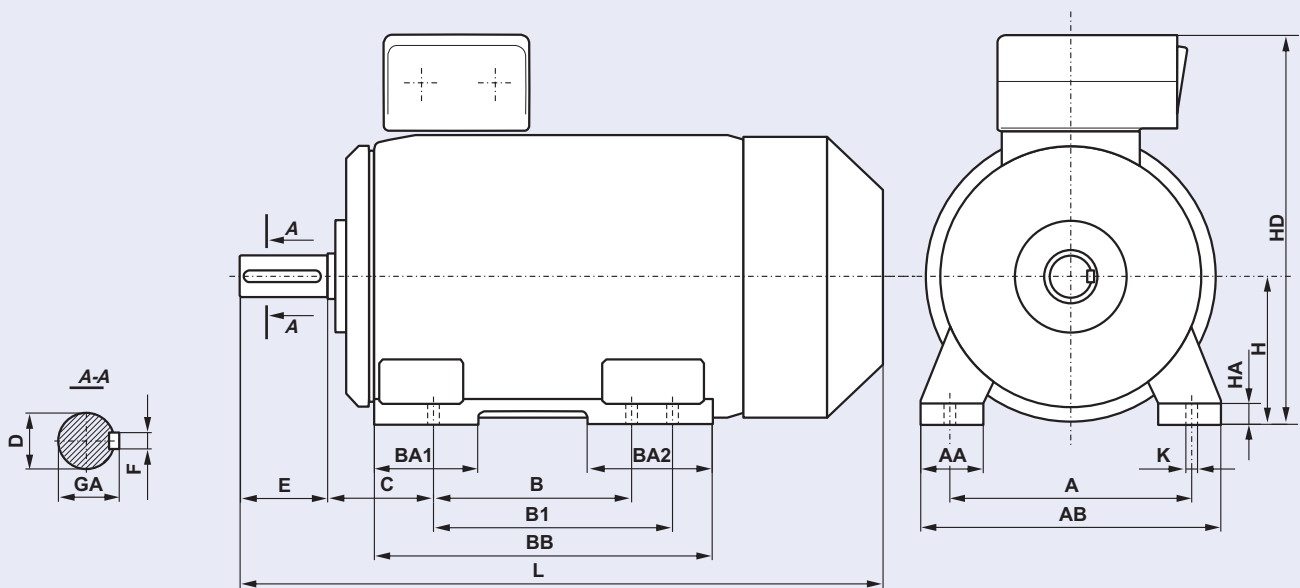

DIMENSIONAL DRAWINGS

| Motor type | A | B | B1 | C | D | E | F | GA | H | HA | K | AA | AB | BA1 | BA2 | BB | HD | L |
|--------------------|-----|-----|-----|-----|-----|-----|----|------|-----|----|----|-----|-----|-----|-----|------|-----|------|
| 2SIE200 | 318 | 305 | - | 133 | 55 | 110 | 16 | 59 | 200 | 32 | 19 | 80 | 400 | 113 | 113 | 380 | 520 | 850 |
| 2SIE225S4 | 356 | 286 | 311 | 149 | 60 | 140 | 18 | 64 | 225 | 34 | 19 | 85 | 440 | 115 | 115 | 380 | 570 | 960 |
| 2SIE225M2 | 356 | 286 | 311 | 149 | 55 | 110 | 16 | 59 | 225 | 34 | 19 | 85 | 440 | 115 | 115 | 380 | 570 | 930 |
| 2SIE225M4-6 | 356 | 286 | 311 | 149 | 60 | 140 | 18 | 64 | 225 | 34 | 19 | 85 | 440 | 115 | 115 | 380 | 570 | 960 |
| 2SIE250M2 | 406 | 349 | - | 168 | 60 | 140 | 18 | 64 | 250 | 37 | 24 | 90 | 480 | 135 | 135 | 445 | 635 | 1010 |
| 2SIE250M4-6 | 406 | 349 | - | 168 | 65 | 140 | 18 | 69 | 250 | 37 | 24 | 90 | 480 | 135 | 135 | 445 | 635 | 1040 |
| 2SIE280S2 | 457 | 368 | 419 | 190 | 65 | 140 | 18 | 69 | 280 | 40 | 24 | 105 | 550 | 130 | 165 | 520 | 720 | 1135 |
| 2SIE280S4-6 | 457 | 368 | 419 | 190 | 75 | 140 | 20 | 79,5 | 280 | 40 | 24 | 105 | 550 | 130 | 165 | 520 | 720 | 1135 |
| 2SIE280M2 | 457 | 368 | 419 | 190 | 65 | 140 | 18 | 69 | 280 | 40 | 24 | 105 | 550 | 130 | 165 | 520 | 720 | 1135 |
| 2SIE280M4-6 | 457 | 368 | 419 | 190 | 75 | 140 | 20 | 79,5 | 280 | 40 | 24 | 105 | 550 | 130 | 165 | 520 | 720 | 1135 |
| 2SIE315S2 | 508 | 406 | 457 | 216 | 65 | 140 | 18 | 69 | 315 | 48 | 28 | 135 | 610 | 135 | 205 | 600 | 805 | 1325 |
| 2SIE315S4-6 | 508 | 406 | 457 | 216 | 80 | 170 | 22 | 85 | 315 | 48 | 28 | 135 | 610 | 135 | 205 | 600 | 805 | 1355 |
| 2SIE315M2A;B;C;D | 508 | 406 | 457 | 216 | 65 | 140 | 18 | 69 | 315 | 48 | 28 | 135 | 610 | 135 | 205 | 600 | 805 | 1325 |
| 2SIE315M4-6A;B;C;D | 508 | 406 | 457 | 216 | 80 | 170 | 22 | 85 | 315 | 48 | 28 | 135 | 610 | 135 | 205 | 600 | 805 | 1355 |
| 2SIE 315 ML (4, 6) | 508 | 457 | 508 | 216 | 80 | 170 | 22 | 85 | 315 | 40 | 28 | 120 | 620 | 150 | 180 | 637 | 865 | 1345 |
| 2SIE 355 ML (2) | 610 | 560 | 630 | 254 | 80 | 170 | 22 | 85 | 355 | 50 | 28 | 150 | 720 | 250 | 300 | 890 | 935 | 1580 |
| 2SIE 355 ML (4, 6) | 610 | 560 | 630 | 254 | 100 | 210 | 28 | 106 | 355 | 50 | 28 | 150 | 720 | 250 | 300 | 890 | 935 | 1620 |
| 2SIE 355 H (2) | 610 | 900 | - | 200 | 70 | 140 | 20 | 74,5 | 355 | 45 | 28 | 160 | 730 | 265 | 265 | 1045 | 995 | 1800 |
| 2SIE 355 H (4, 6) | 610 | 900 | - | 200 | 100 | 210 | 28 | 106 | 355 | 45 | 28 | 160 | 730 | 265 | 265 | 1045 | 995 | 1870 |

FLANGE MOUNTED MOTORS - IM B5, IM V1

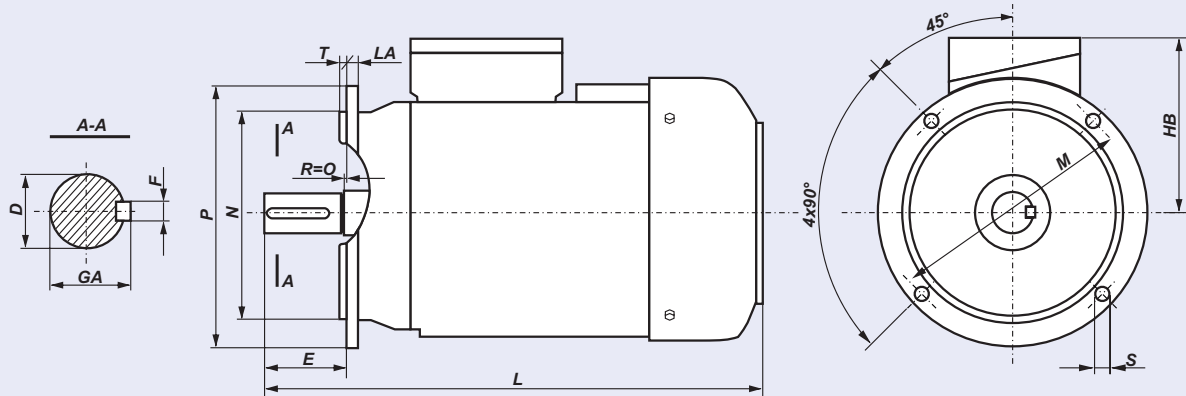

DIMENSIONAL DRAWINGS

| Motor type | D | E | F | GA | M | N | P | LA | T | S | HB | L |
|-----------------------|-------|-----|------|------|-----|-------|-----|------|-----|----|-----|------|
| 2SIEK 80-A | 19j6 | 40 | 6h9 | 21,5 | 165 | 130j6 | 200 | 10 | 3,5 | 12 | 120 | 266 |
| 2SIEK 80-B | 19j6 | 40 | 6h9 | 21,5 | 165 | 130j6 | 200 | 10 | 3,5 | 12 | 120 | 278 |
| 2SIEK 90S-2,4,6 | 24j6 | 50 | 8h9 | 27 | 165 | 130j6 | 200 | 8 | 3,5 | 12 | 130 | 330 |
| 2SIEK 90L-2 | 24j6 | 50 | 8h9 | 27 | 165 | 130j6 | 200 | 8 | 3,5 | 12 | 130 | 330 |
| 2SIEK 90L-4,6 | 24j6 | 50 | 8h9 | 27 | 165 | 130j6 | 200 | 8 | 3,5 | 12 | 130 | 355 |
| 2SIEK 100L-2, 4A | 28j6 | 60 | 8h9 | 31 | 215 | 180j6 | 250 | 11 | 4 | 15 | 140 | 420 |
| 2SIEK 100L-4B | 28j6 | 60 | 8h9 | 31 | 215 | 180j6 | 250 | 11 | 4 | 15 | 140 | 440 |
| 2SIEK 100L-6 | 28j6 | 60 | 8h9 | 31 | 215 | 180j6 | 250 | 11 | 4 | 15 | 140 | 376 |
| 2SIEK 112M-2,6 | 28j6 | 60 | 8h9 | 31 | 215 | 180j6 | 250 | 12 | 4 | 15 | 164 | 384 |
| 2SIEK 112M-4 | 28j6 | 60 | 8h9 | 31 | 215 | 180j6 | 250 | 12 | 4 | 15 | 164 | 411 |
| 2SIEK 132S-2A,6 | 38k6 | 80 | 10h9 | 41 | 265 | 230j6 | 300 | 12 | 4 | 15 | 178 | 463 |
| 2SIEK 132S-2B,4 | 38k6 | 80 | 10h9 | 41 | 265 | 230j6 | 300 | 12 | 4 | 15 | 178 | 501 |
| 2SIEK 132M-4,6A,6B | 38k6 | 80 | 10h9 | 41 | 265 | 230j6 | 300 | 12 | 4 | 15 | 178 | 501 |
| 2SIEK 160M-2A,2B,4,6 | 42k6 | 110 | 12h9 | 45 | 300 | 250j6 | 350 | 13 | 5 | 19 | 210 | 612 |
| 2SIEK 160L-2,4,6 | 42k6 | 110 | 12h9 | 45 | 300 | 250j6 | 350 | 13 | 5 | 19 | 210 | 656 |
| 2SIEK 180M-2,4 | 48k6 | 110 | 14h9 | 51,5 | 300 | 250j6 | 350 | 13 | 5 | 19 | 228 | 705 |
| 2SIEK 180L-4,6 | 48k6 | 110 | 14h9 | 51,5 | 300 | 250j6 | 350 | 13 | 5 | 19 | 228 | 705 |
| 2SIEK 200 | 55 | 110 | 16 | 59 | 350 | 300 | 400 | 16,5 | 5 | 19 | 320 | 850 |
| 2SIEK 225S4 | 60 | 140 | 18 | 64 | 400 | 350 | 450 | 18 | 5 | 19 | 345 | 960 |
| 2SIEK 225M2 | 55 | 110 | 16 | 59 | 400 | 350 | 450 | 18 | 5 | 19 | 345 | 930 |
| 2SIEK 225M4-6 | 60 | 140 | 18 | 64 | 400 | 350 | 450 | 18 | 5 | 19 | 345 | 960 |
| 2SIEK 250M2 | 60 | 140 | 18 | 64 | 500 | 450 | 550 | 23 | 5 | 19 | 385 | 1010 |
| 2SIEK 250M4-6 | 65 | 140 | 18 | 69 | 500 | 450 | 550 | 23 | 5 | 19 | 385 | 1040 |
| 2SIEK 280S2 | 65 | 140 | 18 | 69 | 500 | 450 | 550 | 23 | 5 | 19 | 440 | 1135 |
| 2SIEK 280S4-6 | 75 | 140 | 20 | 79,5 | 500 | 450 | 550 | 23 | 5 | 19 | 440 | 1135 |
| 2SIEK 280M2 | 65 | 140 | 18 | 69 | 500 | 450 | 550 | 23 | 5 | 19 | 440 | 1135 |
| 2SIEK 280M4-6 | 75 | 140 | 20 | 79,5 | 500 | 450 | 550 | 23 | 5 | 19 | 440 | 1135 |
| 2SIEK 315S2 | 65 | 140 | 18 | 69 | 600 | 550 | 660 | 23 | 6 | 24 | 490 | 1325 |
| 2SIEK 315S4-6 | 80 | 170 | 22 | 85 | 600 | 550 | 660 | 23 | 6 | 24 | 490 | 1355 |
| 2SIEK 315M2A;B;C;D* | 65 | 140 | 18 | 69 | 600 | 550 | 660 | 23 | 6 | 24 | 490 | 1325 |
| 2SIEK 315M4-6A;B;C;D* | 80 | 170 | 22 | 85 | 600 | 550 | 660 | 23 | 6 | 24 | 490 | 1355 |
| 2SIEK 355 ML (4 - 6)* | 100m6 | 210 | 28h9 | 106 | 740 | 680 | 800 | 24 | 6 | 22 | 580 | 1620 |
| 2SIEK 355 H (4 - 6)* | 100m6 | 210 | 28h9 | 106 | 740 | 680 | 800 | 24 | 6 | 22 | 638 | 1955 |

* only in vertical position IM V1

FOOT/FLANGE MOUNTED MOTORS - IM B35

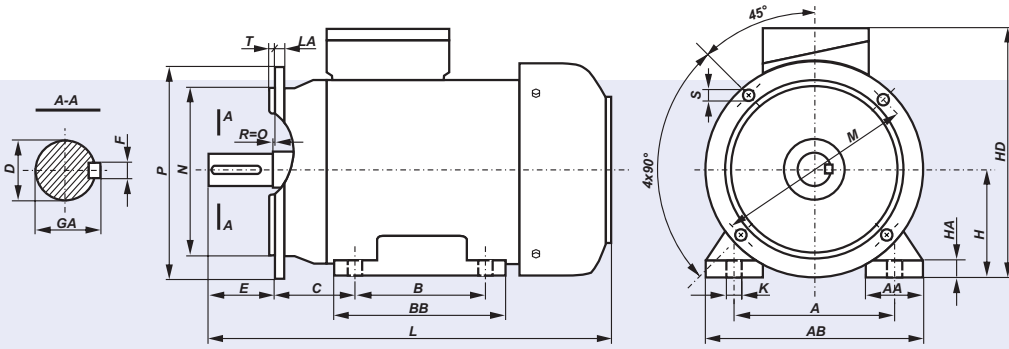

| Motor type | A | B | C | D | E | F | GA | H | K | M | N | P | S | LA | T | AA | AB | BB | HA | HD |
|----------------------|-----|-----|-----|------|-----|------|------|-----|----|-----|-------|-----|----|----|-----|----|-----|-----|----|-----|
| 2SIE 80-A | 125 | 100 | 50 | 19j6 | 40 | 6h9 | 21,5 | 80 | 10 | 165 | 130j6 | 200 | 12 | 10 | 3,5 | 55 | 160 | 130 | 9 | 200 |
| 2SIE 80-B | 125 | 100 | 50 | 19j6 | 40 | 6h9 | 21,5 | 80 | 10 | 165 | 130j6 | 200 | 12 | 10 | 3,5 | 55 | 160 | 130 | 9 | 200 |
| 2SIEL 90S-2,4,6 | 140 | 100 | 56 | 24j6 | 50 | 8h9 | 27 | 90 | 10 | 165 | 130j6 | 200 | 12 | 8 | 3,5 | 50 | 170 | 153 | 10 | 220 |
| 2SIEL 90L-2 | 140 | 125 | 56 | 24j6 | 50 | 8h9 | 27 | 90 | 10 | 165 | 130j6 | 200 | 12 | 8 | 3,5 | 50 | 170 | 153 | 10 | 220 |
| 2SIEL 90L-4,6 | 140 | 125 | 56 | 24j6 | 50 | 8h9 | 27 | 90 | 10 | 165 | 130j6 | 200 | 12 | 8 | 3,5 | 50 | 170 | 153 | 10 | 220 |
| 2SIEL 100L-2, 4A | 160 | 140 | 63 | 28j6 | 60 | 8h9 | 31 | 100 | 12 | 215 | 180j6 | 250 | 15 | 11 | 4 | 45 | 200 | 172 | 14 | 240 |
| 2SIEL 100L-4B | 160 | 140 | 63 | 28j6 | 60 | 8h9 | 31 | 100 | 12 | 215 | 180j6 | 250 | 15 | 11 | 4 | 45 | 200 | 172 | 14 | 240 |
| 2SIEL 100L-6 | 160 | 140 | 63 | 28j6 | 60 | 8h9 | 31 | 100 | 12 | 215 | 180j6 | 250 | 15 | 11 | 4 | 45 | 200 | 172 | 14 | 240 |
| 2SIEL 112M-2,6 | 190 | 140 | 70 | 28j6 | 60 | 8h9 | 31 | 112 | 12 | 215 | 180j6 | 250 | 15 | 12 | 4 | 54 | 230 | 174 | 14 | 276 |
| 2SIEL 112M-4 | 190 | 140 | 70 | 28j6 | 60 | 8h9 | 31 | 112 | 12 | 215 | 180j6 | 250 | 15 | 12 | 4 | 54 | 230 | 174 | 14 | 276 |
| 2SIEL 132S-2A,6 | 216 | 140 | 89 | 38k6 | 80 | 10h9 | 41 | 132 | 12 | 265 | 230j6 | 300 | 15 | 12 | 4 | 56 | 278 | 182 | 16 | 310 |
| 2SIEL 132S-2B,4 | 216 | 140 | 89 | 38k6 | 80 | 10h9 | 41 | 132 | 12 | 265 | 230j6 | 300 | 15 | 12 | 4 | 56 | 278 | 182 | 16 | 310 |
| 2SIEL 132M-4,6A,6B | 216 | 178 | 89 | 38k6 | 80 | 10h9 | 41 | 132 | 12 | 265 | 230j6 | 300 | 15 | 12 | 4 | 56 | 278 | 182 | 16 | 310 |
| 2SIEL 160M-2A,2B,4,6 | 254 | 210 | 108 | 42k6 | 110 | 12h9 | 45 | 160 | 15 | 300 | 250j6 | 350 | 19 | 13 | 5 | 60 | 305 | 256 | 20 | 370 |
| 2SIEL 160L-2,4,6 | 254 | 254 | 108 | 42k6 | 110 | 12h9 | 45 | 160 | 15 | 300 | 250j6 | 350 | 19 | 13 | 5 | 60 | 305 | 300 | 20 | 370 |
| 2SIEL 180M-2,4 | 279 | 241 | 121 | 48k6 | 110 | 14h9 | 51,5 | 180 | 15 | 300 | 250j6 | 350 | 19 | 13 | 5 | 70 | 350 | 320 | 26 | 408 |
| 2SIEL 180L-4,6 | 279 | 279 | 121 | 48k6 | 110 | 14h9 | 51,5 | 180 | 15 | 300 | 250j6 | 350 | 19 | 13 | 5 | 70 | 350 | 320 | 26 | 408 |

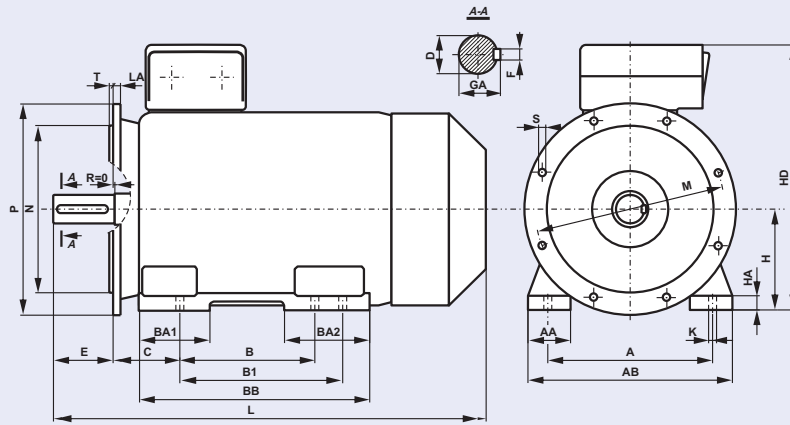

| Motor type | A | B | B1 | C | D | E | F | GA | H | HA | K | AA | AB | BA1 | BA2 | BB | HD | LA | P | M | N | S | T | L |
|----------------------|-----|-----|-----|-----|-----|-----|----|------|-----|----|----|-----|-----|-----|-----|------|-----|------|-----|-----|-----|----|---|------|
| 2SIEL 200 | 318 | 305 | - | 133 | 55 | 110 | 16 | 59 | 200 | 32 | 19 | 80 | 400 | 113 | 113 | 380 | 520 | 16,5 | 400 | 350 | 300 | 19 | 5 | 850 |
| 2SIEL 225S4 | 356 | 286 | 311 | 149 | 60 | 140 | 18 | 64 | 225 | 34 | 19 | 85 | 440 | 115 | 115 | 380 | 570 | 18 | 450 | 400 | 350 | 19 | 5 | 960 |
| 2SIEL 225M2 | 356 | 286 | 311 | 149 | 55 | 110 | 16 | 59 | 225 | 34 | 19 | 85 | 440 | 115 | 115 | 380 | 570 | 18 | 450 | 400 | 350 | 19 | 5 | 930 |
| 2SIEL 225M4-6 | 356 | 286 | 311 | 149 | 60 | 140 | 18 | 64 | 225 | 34 | 19 | 85 | 440 | 115 | 115 | 380 | 570 | 18 | 450 | 400 | 350 | 19 | 5 | 960 |
| 2SIEL 250M2 | 406 | 349 | - | 168 | 60 | 140 | 18 | 64 | 250 | 37 | 24 | 90 | 480 | 135 | 135 | 445 | 635 | 23 | 550 | 500 | 450 | 19 | 5 | 1010 |
| 2SIEL 250M4-6 | 406 | 349 | - | 168 | 65 | 140 | 18 | 69 | 250 | 37 | 24 | 90 | 480 | 135 | 135 | 445 | 635 | 23 | 550 | 500 | 450 | 19 | 5 | 1040 |
| 2SIEL 280S2 | 457 | 368 | 419 | 190 | 65 | 140 | 18 | 69 | 280 | 40 | 24 | 105 | 550 | 130 | 165 | 520 | 720 | 23 | 550 | 500 | 450 | 19 | 5 | 1135 |
| 2SIEL 280S4-6 | 457 | 368 | 419 | 190 | 75 | 140 | 20 | 79,5 | 280 | 40 | 24 | 105 | 550 | 130 | 165 | 520 | 720 | 23 | 550 | 500 | 450 | 19 | 5 | 1135 |
| 2SIEL 280M2 | 457 | 368 | 419 | 190 | 65 | 140 | 18 | 69 | 280 | 40 | 24 | 105 | 550 | 130 | 165 | 520 | 720 | 23 | 550 | 500 | 450 | 19 | 5 | 1135 |
| 2SIEL 280M4-6 | 457 | 368 | 419 | 190 | 75 | 140 | 20 | 79,5 | 280 | 40 | 24 | 105 | 550 | 130 | 165 | 520 | 720 | 23 | 550 | 500 | 450 | 19 | 5 | 1135 |
| 2SIEL 315S2 | 508 | 406 | 457 | 216 | 65 | 140 | 18 | 69 | 315 | 48 | 28 | 135 | 610 | 135 | 205 | 600 | 805 | 23 | 660 | 600 | 550 | 24 | 6 | 1325 |
| 2SIEL 315S4-6 | 508 | 406 | 457 | 216 | 80 | 170 | 22 | 85 | 315 | 48 | 28 | 135 | 610 | 135 | 205 | 600 | 805 | 23 | 660 | 600 | 550 | 24 | 6 | 1355 |
| 2SIEL 315M2A;B;C;D | 508 | 406 | 457 | 216 | 65 | 140 | 18 | 69 | 315 | 48 | 28 | 135 | 610 | 135 | 205 | 600 | 805 | 23 | 660 | 600 | 550 | 24 | 6 | 1325 |
| 2SIEL 315M4-6A;B;C;D | 508 | 406 | 457 | 216 | 80 | 170 | 22 | 85 | 315 | 48 | 28 | 135 | 610 | 135 | 205 | 600 | 805 | 23 | 660 | 600 | 550 | 24 | 6 | 1355 |
| 2SIEL 315 ML (4,6) | 508 | 457 | 508 | 216 | 80 | 170 | 22 | 85 | 315 | 40 | 28 | 120 | 620 | 150 | 180 | 637 | 865 | 22 | 660 | 600 | 550 | 22 | 6 | 1345 |
| 2SIEL 355 ML (2) | 610 | 560 | 630 | 254 | 80 | 170 | 22 | 85 | 355 | 50 | 28 | 150 | 720 | 250 | 300 | 890 | 935 | 24 | 800 | 740 | 680 | 22 | 6 | 1580 |
| 2SIEL 355 ML (4,6) | 610 | 560 | 630 | 254 | 100 | 210 | 28 | 106 | 355 | 50 | 28 | 150 | 720 | 250 | 300 | 890 | 935 | 24 | 800 | 740 | 680 | 22 | 6 | 1620 |
| 2SIEL 355 H (2) | 610 | 900 | - | 254 | 70 | 140 | 20 | 74,5 | 355 | 45 | 28 | 160 | 730 | 265 | 265 | 1045 | 995 | 24 | 800 | 740 | 680 | 22 | 6 | 1854 |
| 2SIEL 355 H (4,6) | 610 | 900 | - | 254 | 100 | 210 | 28 | 106 | 355 | 45 | 28 | 160 | 730 | 265 | 265 | 1045 | 995 | 24 | 800 | 740 | 680 | 22 | 6 | 1924 |

DIMENSIONAL DRAWINGS

FLANGE MOUNTED MOTORS - IM B14



DIMENSIONAL DRAWINGS

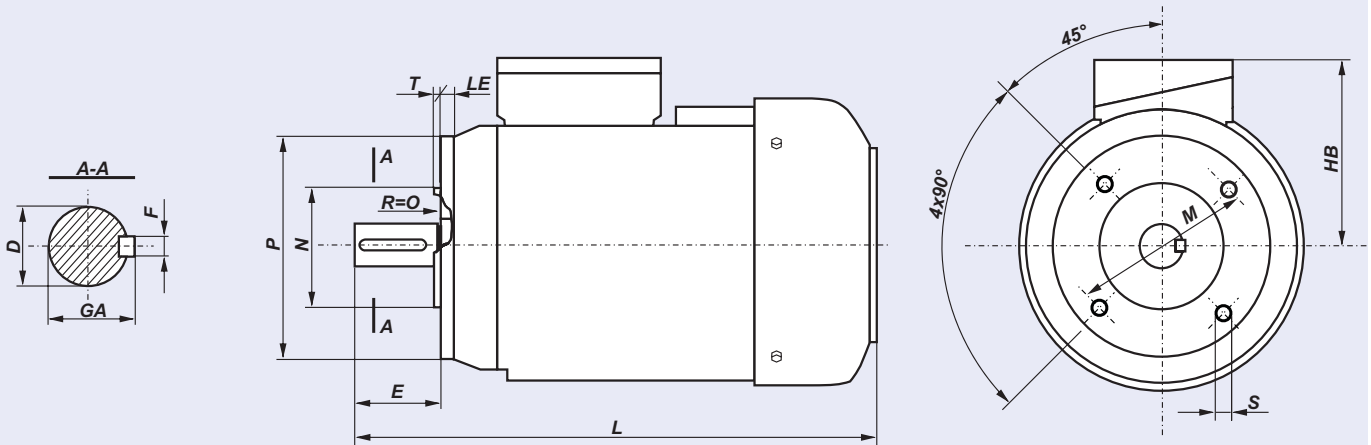

| Motor type | Flange | D | E | F | GA | M | N | P | S | T | LE | HB | L |
|-------------------|--------|------|----|------|------|-----|-------|-----|-----|-----|----|-----|-----|
| 2SIEK 80- .A1 | B14/C1 | 19j6 | 40 | 6h9 | 21,5 | 130 | 110j6 | 160 | M8 | 3,5 | 14 | 120 | 266 |
| 2SIEK 80- .A2 | B14/C2 | 19j6 | 40 | 6h9 | 21,5 | 100 | 80j6 | 120 | M6 | 3 | 12 | 120 | 266 |
| 2SIEK 80- .B1 | B14/C1 | 19j6 | 40 | 6h9 | 21,5 | 130 | 110j6 | 160 | M8 | 3,5 | 14 | 120 | 278 |
| 2SIEK 80- .B2 | B14/C2 | 19j6 | 40 | 6h9 | 21,5 | 100 | 80j6 | 120 | M6 | 3 | 12 | 120 | 278 |
| 2SIEK 90S ... | B14/C1 | 24j6 | 50 | 8h9 | 27 | 130 | 110j6 | 160 | M8 | 3,5 | 10 | 130 | 330 |
| 2SIEK 90S ... | B14/C2 | 24j6 | 50 | 8h9 | 27 | 115 | 95j6 | 140 | M8 | 3 | 10 | 130 | 330 |
| 2SIEK 90L ... | B14/C1 | 24j6 | 50 | 8h9 | 27 | 130 | 110j6 | 160 | M8 | 3,5 | 10 | 130 | 330 |
| 2SIEK 90L ... | B14/C2 | 24j6 | 50 | 8h9 | 27 | 115 | 95j6 | 140 | M8 | 3 | 10 | 130 | 330 |
| 2SIEK 100L2,4A | B14/C1 | 28j6 | 60 | 8h9 | 31 | 165 | 130j6 | 200 | M10 | 3,5 | 12 | 140 | 420 |
| 2SIEK 100L2,4A | B14/C2 | 28j6 | 60 | 8h9 | 31 | 130 | 110j6 | 160 | M8 | 3,5 | 12 | 140 | 420 |
| 2SIEK 100L4B | B14/C1 | 28j6 | 60 | 8h9 | 31 | 165 | 130j6 | 200 | M10 | 3,5 | 12 | 140 | 440 |
| 2SIEK 100L4B | B14/C2 | 28j6 | 60 | 8h9 | 31 | 130 | 110j6 | 160 | M8 | 3,5 | 12 | 140 | 440 |
| 2SIEK 100L6 | B14/C1 | 28j6 | 60 | 8h9 | 31 | 165 | 130j6 | 200 | M10 | 3,5 | 12 | 140 | 376 |
| 2SIEK 100L6 | B14/C2 | 28j6 | 60 | 8h9 | 31 | 130 | 110j6 | 160 | M8 | 3,5 | 12 | 140 | 376 |
| 2SIEK 112M2,6 | B14/C1 | 28j6 | 60 | 8h9 | 31 | 165 | 130j6 | 200 | M10 | 3,5 | 12 | 164 | 384 |
| 2SIEK 112M2,6 | B14/C2 | 28j6 | 60 | 8h9 | 31 | 130 | 110j6 | 160 | M8 | 3,5 | 12 | 164 | 384 |
| 2SIEK 112M4 | B14/C1 | 28j6 | 60 | 8h9 | 31 | 165 | 130j6 | 200 | M10 | 3,5 | 12 | 164 | 411 |
| 2SIEK 112M4 | B14/C2 | 28j6 | 60 | 8h9 | 31 | 130 | 110j6 | 160 | M8 | 3,5 | 12 | 164 | 411 |
| 2SIEK 132S2A,6 | B14/C1 | 38k6 | 80 | 10h9 | 41 | 215 | 180j6 | 250 | M12 | 4 | 12 | 178 | 463 |
| 2SIEK 132S2A,6 | B14/C2 | 38k6 | 80 | 10h9 | 41 | 165 | 130j6 | 200 | M10 | 3,5 | - | 178 | 463 |
| 2SIEK 132S2B,4 | B14/C1 | 38k6 | 80 | 10h9 | 41 | 215 | 180j6 | 250 | M12 | 4 | 12 | 178 | 501 |
| 2SIEK 132S2B,4 | B14/C2 | 38k6 | 80 | 10h9 | 41 | 165 | 130j6 | 200 | M10 | 3,5 | - | 178 | 501 |
| 2SIEK 132M4,6A,6B | B14/C1 | 38k6 | 80 | 10h9 | 41 | 215 | 180j6 | 250 | M12 | 4 | 12 | 178 | 501 |
| 2SIEK 132M4,6A,6B | B14/C2 | 38k6 | 80 | 10h9 | 41 | 165 | 130j6 | 200 | M10 | 3,5 | - | 178 | 501 |

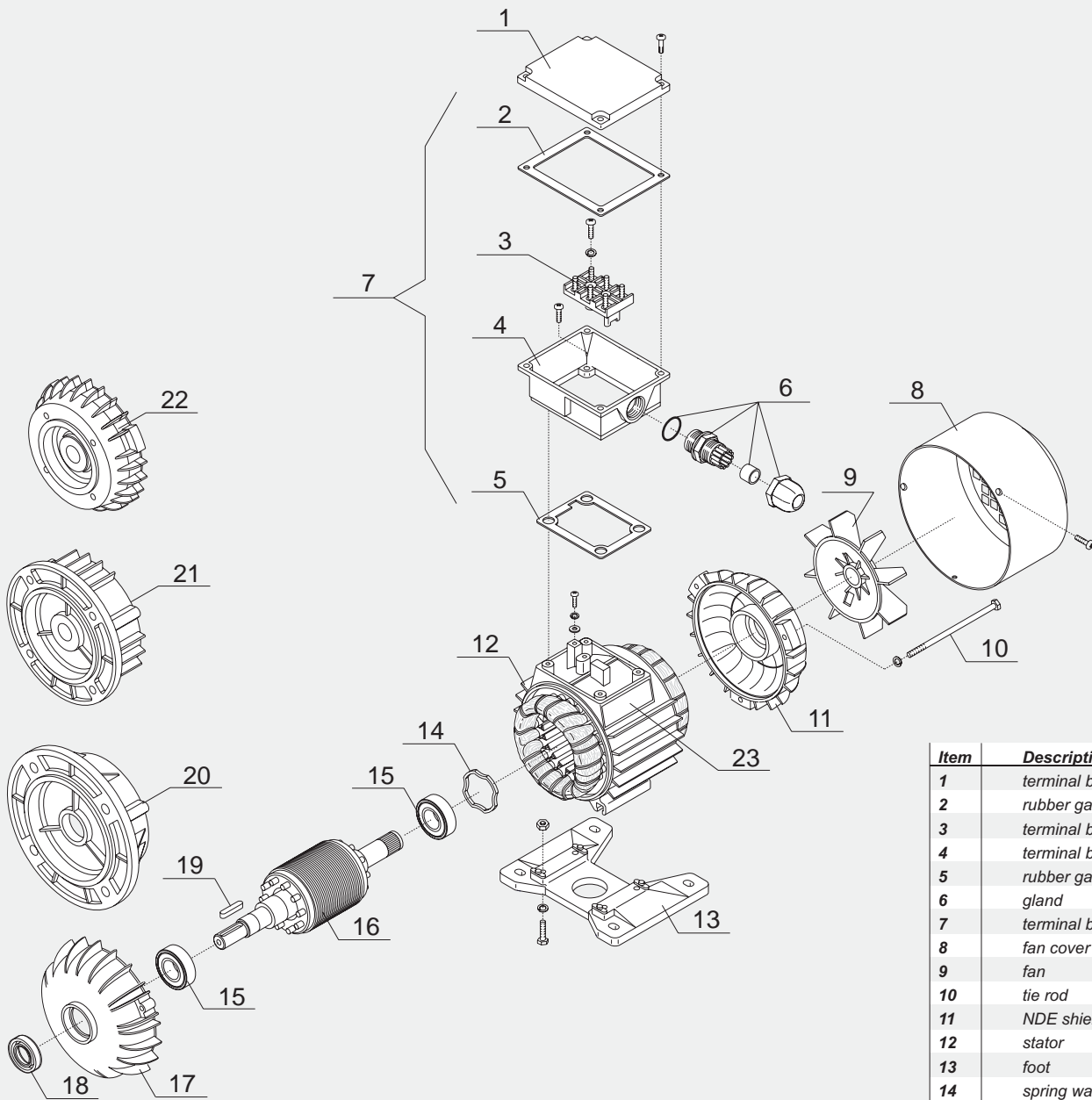

| Item | Description |
|------|-----------------------|
| 1 | terminal box cover |
| 2 | rubber gasket |
| 3 | terminal board |
| 4 | terminal box |
| 5 | rubber gasket |
| 6 | gland |
| 7 | terminal box complete |
| 8 | fan cover |
| 9 | fan |
| 10 | tie rod |
| 11 | NDE shield |
| 12 | stator |
| 13 | foot |
| 14 | spring washer |
| 15 | bearing |
| 16 | rotor |
| 17 | DE shield |
| 18 | shaft seal |
| 19 | key |
| 20 | flange B5 |
| 21 | flange B14/C1 |
| 22 | flange B14/C2 |
| 23 | name plate |

DE - drive end
NDE - non drive end

LIST OF MOTOR PARTS

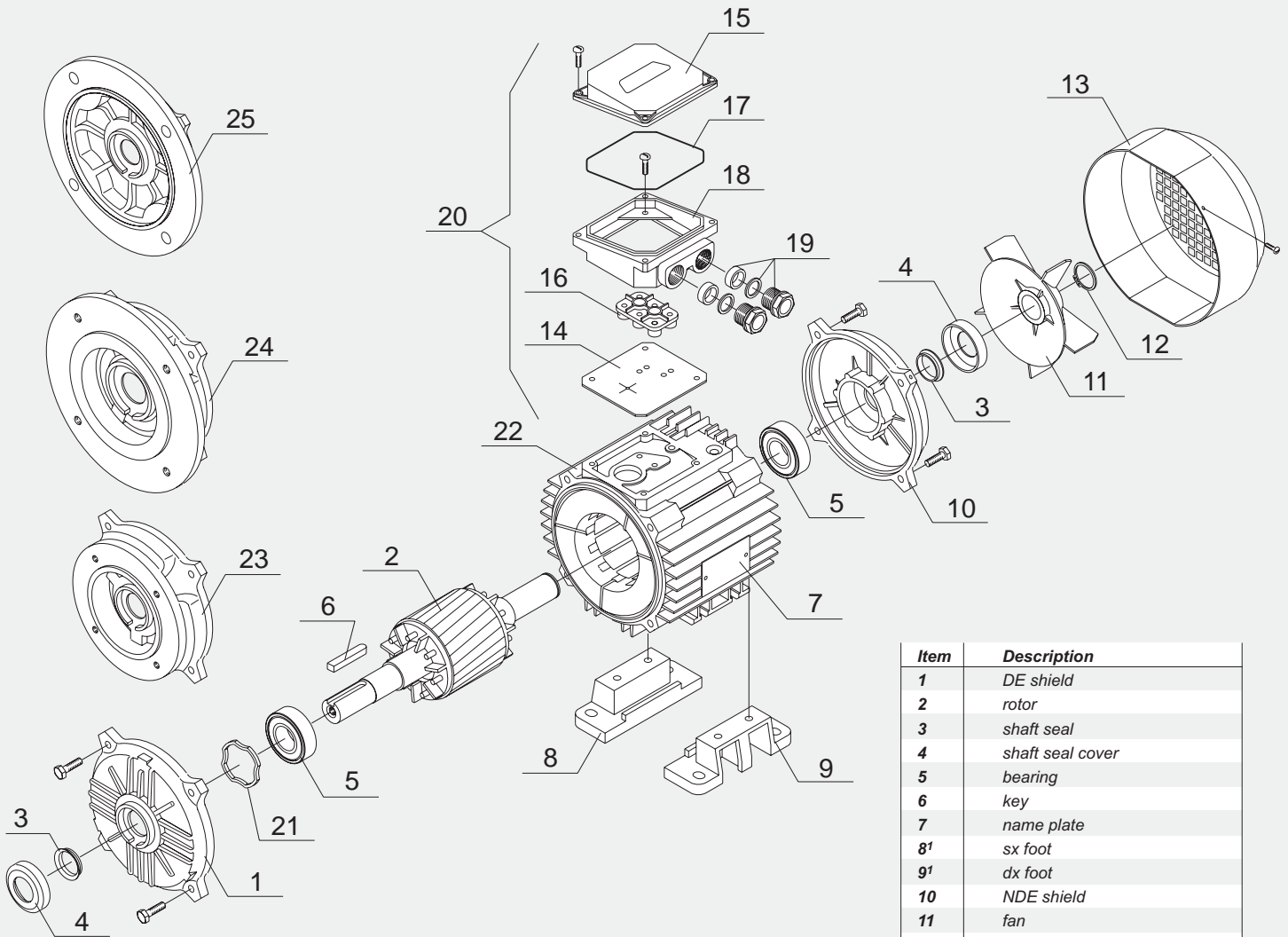

| Item | Description |
|-----------------|-----------------------|
| 1 | DE shield |
| 2 | rotor |
| 3 | shaft seal |
| 4 | shaft seal cover |
| 5 | bearing |
| 6 | key |
| 7 | name plate |
| 8 ¹ | sx foot |
| 9 ¹ | dx foot |
| 10 | NDE shield |
| 11 | fan |
| 12 | seeger ring |
| 13 | fan cover |
| 14 | rubber gasket |
| 15 | terminal box cover |
| 16 | terminal board |
| 17 | rubber gasket |
| 18 | terminal box |
| 19 | glands |
| 20 | terminal box complete |
| 21 | spring washer |
| 22 | stator |
| 23 ² | flange B14/C2 |
| 24 ² | flange B14/C1 |
| 25 | flange B5 |

DE - drive end
NDE - non drive end

1 - for frame size 132 feet can be screwed or integrated with the motor housing, for frame size 160 -180 feet are integrated with the motor housing.
2 - only for frame size 90 - 132.

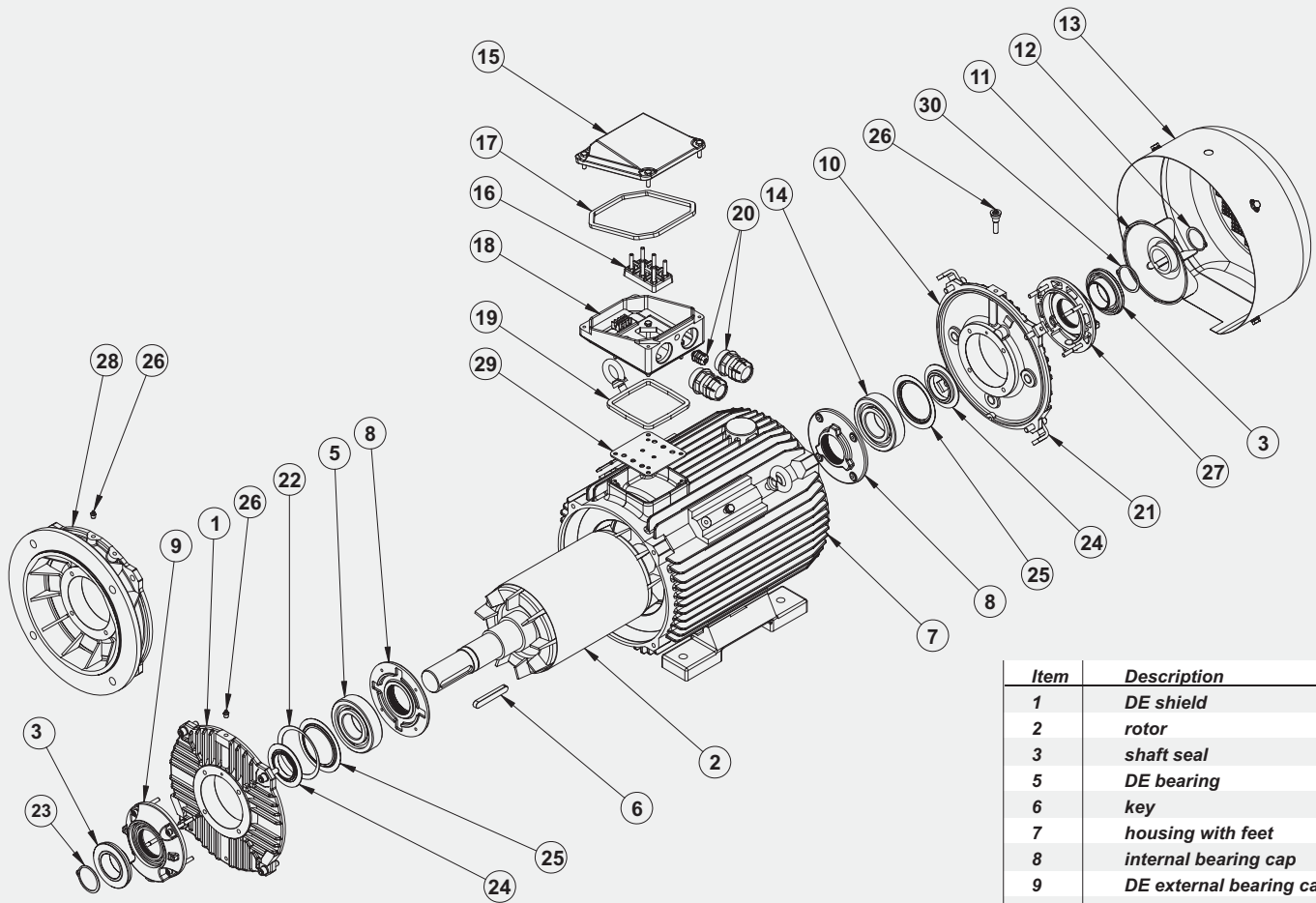

| Item | Description |
|------|--------------------------|
| 1 | DE shield |
| 2 | rotor |
| 3 | shaft seal |
| 5 | DE bearing |
| 6 | key |
| 7 | housing with feet |
| 8 | internal bearing cap |
| 9 | DE external bearing cap |
| 10 | NDE shield |
| 11 | fan |
| 12 | seeger ring |
| 13 | fan cover |
| 14 | NDE bearing |
| 15 | terminal box cover |
| 16 | terminal board |
| 17 | rubber gasket |
| 18 | terminal box housing |
| 19 | rubber gasket |
| 20 | cable glands |
| 21 | fan cover support |
| 22 | spring washer |
| 23 | seeger ring |
| 24 | grease shield |
| 25 | bearing internal ring |
| 26 | grease nipple |
| 27 | NDE external bearing cap |
| 28 | flange B5 |
| 29 | rubber gasket |
| 30 | seeger ring |

LIST OF MOTOR PARTS

DE - drive end
NDE - non drive end

PRODUCTION PROGRAM

GENERAL PURPOSE 3-PHASE INDUCTION MOTORS

GENERAL PURPOSE 1-PHASE INDUCTION MOTORS

HIGH VOLTAGE INDUCTION MOTORS

Totally enclosed motors IP55

Totally enclosed motors for power engineering IP55

Open drip proof motors IP23

MOTORS WITH INCREASED RATED OUTPUT

MOTORS WITH FOREIGN COOLING

Motors with foreign cooling IP54 (IP55)

Motors with foreign cooling IP20

3-PHASE INDUCTION MOTORS FOR PUMPS

Standard motors for pumps

Explosion-proof motors for pumps

Explosion-proof marine motors for pumps

MOTORS TO BE BUILT-IN

1-phase motors to be built-in

3-phase motors to be built-in

BRAKE MOTORS

Brake motors (with DC brake)

Brake motors (with AC brake)

EXPLOSION-PROOF MOTORS

Increased safety motors

Flame-proof motors

Flame-proof marine motors

Special purpose flame-proof motors for mining

Special purpose flame-proof motors for chemical industry

Special purpose flame-proof marine motors

High voltage flame-proof motors

MOTORS FOR AXIAL-FLOW FANS

1-phase motors for axial-flow fans

3-phase motors for axial-flow fans

3-phase motors for axial-flow mining fans

3-phase explosion-proof motors for air duct axial-flow fans

3-phase marine motors for axial-flow fans

3-phase explosion-proof marine motors for axial-flow fans

3-phase multi-speed motors for axial-flow fans

3-phase multi-speed motors for air duct axial-flow fans

PRODUCTION PROGRAM

MULTI-SPEED MOTORS

- General purpose 2-speed motors
- General purpose multi-speed motors

MARINE MOTORS

- General purpose marine motors
- Marine motors for pumps
- Marine motors for axial-flow fans
- Marine motors for boat davits
- Marine motors for tubular rudders
- General purpose explosion-proof marine motors
- Explosion-proof marine motors for pumps
- Explosion-proof marine motors for axial-flow fans

SLIP RING INDUCTION MOTORS

- Totally enclosed (IP 54, 55) wound rotor induction motors
- Open drip proof (IP 23) wound rotor induction motors

CRANE MOTORS

- Squirrel cage crane motors
- Slip ring rotor crane motors
- Two-speed crane motors with brake

SPECIAL PURPOSE INDUCTION MOTORS

- Motors with increased slip
- Roller table motors for iron and steel industry
- 1-phase motors with shaft height 65 mm
- 3-phase motors with shaft height 65 mm

MOTORS ACCORDING TO EPACT AND PREMIUM REQUIREMENTS

ACCESSORIES

- DC electromagnetic disc brakes
- AC electromagnetic disc brakes
- Powder brakes and clutches
- Thrustors