

EDC Series User's Manual Operation of Version 2



Preface

This manual describes the operation of the Estun servo drive type EDC and is meant for operators who are instructed for operation of the device.

Estun Limited Warranty

This manual does not entitle you to any rights. Estun reserves the right to change this manual without prior notice. All rights reserved. The copyright is held by Estun. No part of this publication can be copied or reproduced without written permission from Estun.

General Precaution

- Power supply voltage should be AC 220V.

The EDC servo system requires a power supply of AC 220V+/-15% voltage.

- Don't connect the servo motor directly to local electric network.

It's prohibited to connect the servo motor directly to local electric network. Otherwise, the servo motor is very likely to get damaged. The servo motor will not rotate without support of servo drive.

- Don't plug in or unplug the connectors when power is ON.

Internal circuit and motor encoder might be damaged if the plug in or unplug operations are performed during power ON. Always turn the power OFF first before plugging in or unplugging the connectors.

- Wait for at least 5 minutes before doing inspection work on the servo system after turning power OFF.

Please be noted that even when the power is turned off, there will still be some electric energy remained in the capacitors of the internal circuit. In order to avoid electrical shock, please make sure inspection work is started 5 minutes after Charge indicator is OFF.

- There should be a space of at least 10mm between the servo drive and any other devices mounted in the electrical cabinet.

The servo drive produces heat during working, heat dissipation should be considered in design of mounting layout. At least 10 mm space in lateral direction and 50 mm space in longitudinal direction are required from servo drive to other equipments when doing installation. Please install the servo drive in an environment which is free from condensation, vibration and shock.

- Noise rejection treatment and grounding.

The noise from signal wires causes easily the mechanical vibration and malfunctions. Please comply with the following rules strictly:

- Route high-voltage power cables separately from low-voltage power cables.

- Make short cable route as possible.

- Single point grounding is required when mounting the servo motor and servo drive, and

- grounding resistance should be lower than 100Ω.

- It's prohibited to apply power input noise filter between servo drive and servo motor.

- Withstand voltage test of servo drive should meet following conditions:

- Input voltage: AC 1500Vrms, 1 minute

- Interrupt/Break current: 100mA

- Frequency: 50/60Hz

- Forcing point: Between Terminal R, Terminal T and Terminal E.

- Apply a fast-response leakage protector

It's required to use a fast-response leakage protector or a leakage protector for

PWM inverter designated by supplier. Do not use a time delay leakage protector.

■ Avoid extreme adjustments or changes

Don't make extreme adjustments or changes to servo drive's parameters, which will cause terrible mechanical vibration and result in unnecessary property loss.

■ Don't run the servo motor by switching On/Off the power supply directly.

Frequent power On/Off will cause fast aging to servo's internal components, which will reduce the lifetime of servo drive. It's required to use reference signals to control the running of servo motor.

Contents

Preface	- 1 -
Estun Limited Warranty.....	- 1 -

General Precaution	- 2 -
Table of contents.....	- 3 -
Chapter 1 Checking products on delivery and product specification.....	- 7 -
1.1 Checking products on delivery.....	- 7 -
1.1.1 Servo motor.....	- 7 -
Nameplate.....	- 7 -
Identification of motor model	- 8 -
1.1.2 Servo drive	- 9 -
Nameplate.....	- 9 -
Identification of drive model	- 9 -
1.2 Servo components description.....	- 10 -
1.2.1 servo motor	- 10 -
1.2.2 Servo drive	- 10 -
Chapter 2 Installation	- 12 -
2.1 Servo motor	- 12 -
2.1.1 Storage temperature	- 12 -
2.1.2 Installation site.....	- 12 -
2.1.3 Installation concentricity	- 12 -
2.1.4 Installation direction.....	- 13 -
2.1.5 Handling oil and water	- 13 -
2.1.6 Cable tension	- 14 -
2.2 Servo drive	- 14 -
2.2.1 Storage condition.....	- 14 -
2.2.2 Installation site.....	- 14 -
2.2.3 Installation orientation.....	- 15 -
2.2.4 Installation of several servo drives.....	- 15 -
Chapter 3 Wiring.....	- 17 -
3.1 Wiring and connection	- 17 -
3.1.1 Names and Functions of Main Circuit Terminals.....	- 17 -
3.2 I/O signals.....	- 19 -
3.2.1 Standard connection diagram (example).....	- 19 -
3.2.2 Connector terminals	- 19 -
3.2.3 Function list of I/O signals	- 20 -
3.2.4 Interface circuit example.....	- 22 -
3.3 Encoder wiring	- 24 -
3.3.1 Encoder wiring (2CN)	- 24 -
3.3.2 Signal list of connectors (2CN)	- 24 -
3.4 Motor wiring	- 25 -
3.4.1 Motor encoder terminals.....	- 25 -
3.4.2 Motor power terminal.....	- 26 -
3.5 Standard connection example	- 27 -
Chapter 4 Function setting and description.....	- 28 -
4.1 Machine related settings.....	- 28 -
4.1.1 Servomotor rotation direction Select.....	- 28 -

4.1.2 Overtravel.....	- 29 -
4.1.3 Stop function.....	- 31 -
4.1.4 Limiting torque.....	- 32 -
4.2 Settings complying with host controller.....	- 33 -
4.2.1 Position control.....	- 35 -
4.2.2 Encoder signal output.....	- 40 -
4.2.3 Sequence I/O signal.....	- 43 -
4.2.4 Electronic gear.....	- 46 -
4.2.5 Position contact control.....	- 50 -
4.2.6 Zero adjustment.....	- 54 -
4.2.7 Parameter speed control.....	- 57 -
4.3 Servo drive settings.....	- 60 -
4.3.1 JOG speed.....	- 60 -
4.3.2 Control selection.....	- 60 -
4.4 Stop function settings.....	- 62 -
4.4.1 Dynamic brake.....	- 62 -
4.4.2 Holding brake.....	- 63 -
4.5 Protection sequence design.....	- 67 -
4.5.1 Servo alarm output.....	- 67 -
4.5.2 /S-ON input.....	- 68 -
4.5.3 Positioning complete output.....	- 70 -
4.5.4 Speed coincidence output.....	- 71 -
4.5.5 Handling instant power cut.....	- 72 -
4.5.6 Regenerative braking unit.....	- 73 -
4.6 Smooth running.....	- 74 -
4.6.1 Smoothing.....	- 74 -
4.6.2 Acceleration/deceleration time.....	- 74 -
4.6.3 Speed detection smoothing time constant.....	- 76 -
4.6.4 Torque reference filter time constant.....	- 76 -
4.7 High speed positioning.....	- 76 -
4.7.1 Servo gain settings.....	- 76 -
4.7.2 Speed offset settings.....	- 79 -
Chapter 5 Troubleshooting.....	- 81 -
5.1 Alarm list.....	- 81 -
5.2 Alarm reasons and Troubleshootings.....	- 82 -
5.3 Clear alarm.....	- 85 -
Chapter 6 Panel Operator.....	- 86 -
6.1 Basic Function.....	- 86 -
6.1.1 Function description.....	- 86 -
6.1.2 Reset Servo Alarms.....	- 86 -
6.1.3 Display mode selection.....	- 87 -
6.1.4 Status Display Mode.....	- 88 -
6.1.5 Parameter Setting Mode.....	- 90 -
6.1.6 Monitor Mode.....	- 91 -

6.2 Auxiliary functions	- 94 -
6.2.1 Alarm history display	- 94 -
6.2.2 Restore to factory settings	- 95 -
6.2.3 JOG operation	- 95 -
6.2.4 Automatic offset signals adjustment of motor current detection	- 96 -
6.2.5 Servo software version display	- 97 -
6.2.6 System runtime	- 98 -
6.2.7 Software version of panel operator	- 98 -
6.2.8 Factory test	- 98 -
6.2.9 Inertia inspection	- 98 -
Chapter 7 Trial operation	- 99 -
7.1 Inspection and checking before trial operation	- 99 -
7.2 JOG operation	- 100 -
7.3 Trial operation in position control mode	- 101 -
Chapter 8 Communication	- 102 -
8.1 RS232 communication hardware structure	- 102 -
8.1.1 External connection diagram	- 102 -
8.1.2 Cable connection	- 102 -
8.2 Communication relevant parameters	- 103 -
8.3 MODBUS communication protocol	- 106 -
8.3.1 Code signification	- 106 -
8.3.2 Communication error handling	- 113 -
8.3.3 Parameters, servo status data communication address	- 114 -
Chapter 9 Technical specification and features	- 119 -
9.1 Servomotor	- 119 -
9.1.1 Technical specification and features	- 119 -
9.1.2 Servomotor mounting dimension	- 122 -
9.1.3 Servomotor connection diagram	- 122 -
9.2 Servo drive	- 123 -
9.2.1 Technical specification and model	- 123 -
9.2.2 Servo drive mounting dimension	- 125 -
Appendix A	- 125 -
Parameter list	- 125 -
Appendix B	- 133 -
Alarm list	- 133 -

Chapter 1 Checking products on delivery and product specification

1.1 Checking products on delivery

Check following items when EDC series products are delivered.

Check Items	Comments
Are the delivered products the ones that were ordered?	Check the model numbers marked on the nameplate of servo motor and servo drive.
Is there any damage?	Check the overall appearance, and check for damage or scratches that have occurred during shipping.
Can the rotors run well?	Motor rotors can rotate gently with hand, there's no abnormal noise, and a motor with brake mustn't rotate.

If any of above items are faulty or incorrect, contact your dealer from whom you purchased the products or the service personnel of Estun.

1.1.1 Servo motor

Nameplate

The following illustration shows an example of the servo motor's nameplate.

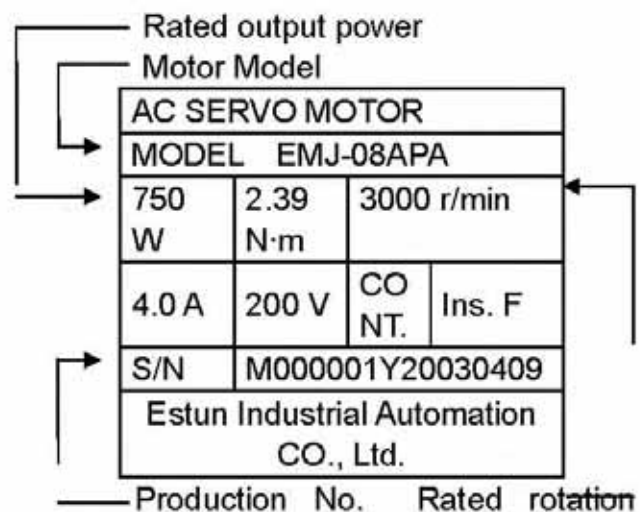

speed

Identification of motor model

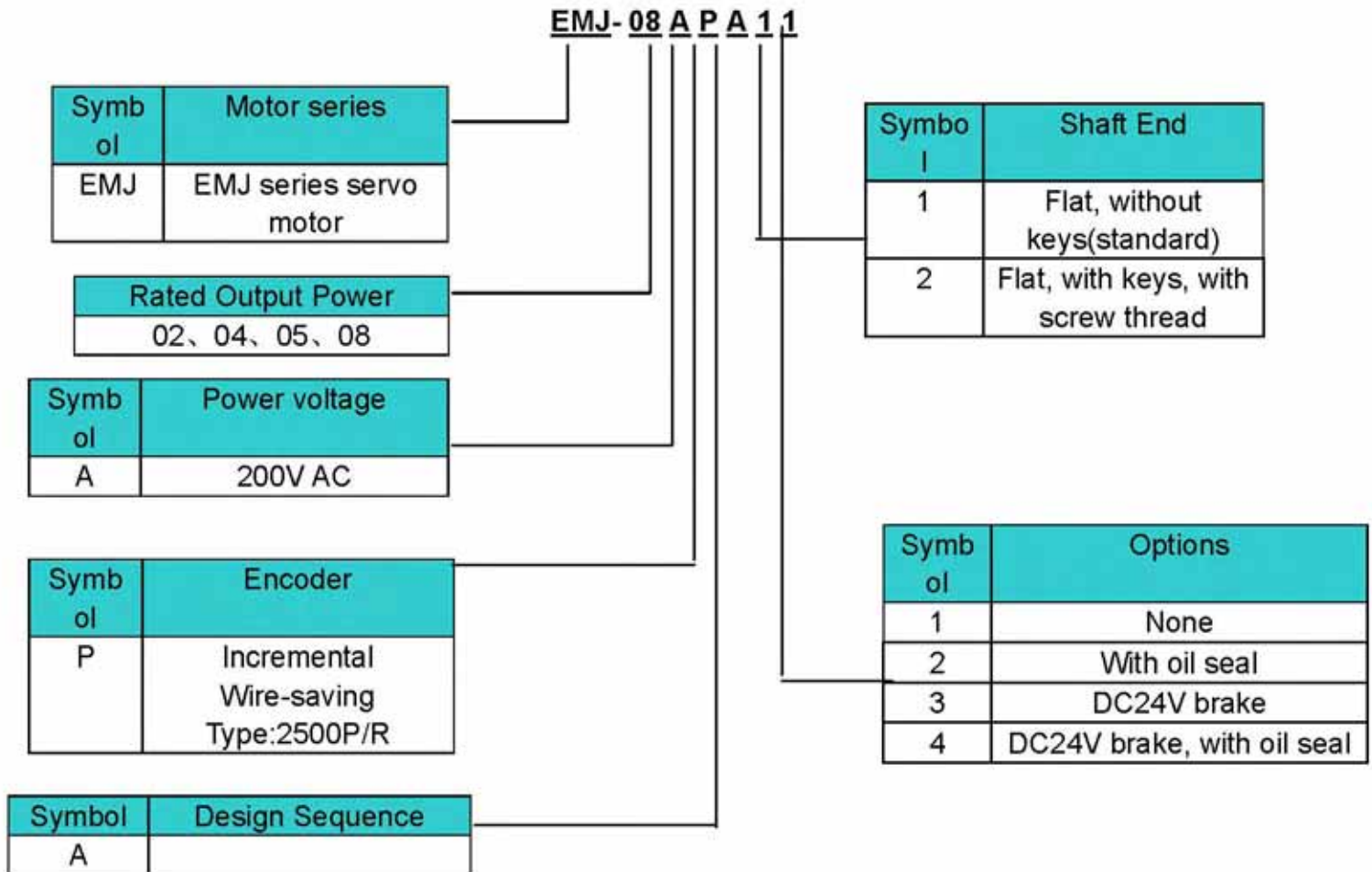



1.1.2 Servo drive

Nameplate



Type →

ESTUN		SERVODRIVE	
MODEL EDC-08APE			
AC-INPUT		AC-OUTPUT	
1PH 200-230V 50/60Hz	6.3A	3PH 0-200V 0-333Hz	4.0A 750W
S/N: 6200887G028			
			
Estun Automation Technology Co., Ltd. Made in China			
 Hazardous Voltage Do not touch drive unit and wiring within 15 minutes after power off. Risk of electric shock.		 High Temperature Do not touch heatsink when power is ON. Risk of burn.	

Identification of drive model

EDC-08 A P E

Drive series
EDC series servo drive

Drive model
02、04、05、08

Designing Sequence
E

Symb ol	Control method
P	Position control

Sym bol	Power Voltage
A	200V

1.2 Servo components description

1.2.1 servo motor

Following illustration shows the names of the components of a servo motor without gear down device and brake.

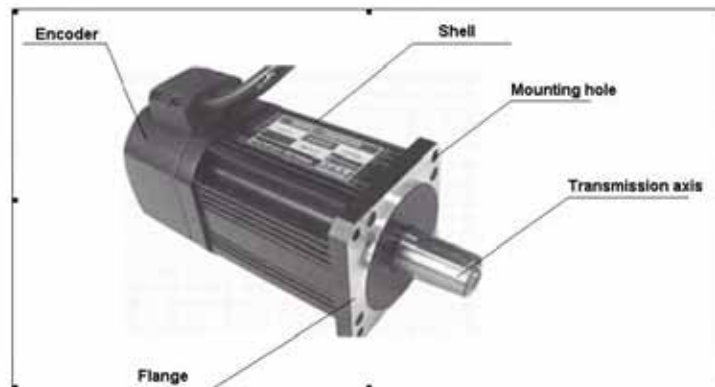

1.2.2 Servo drive

Following illustration shows the names of the components of a servo drive.

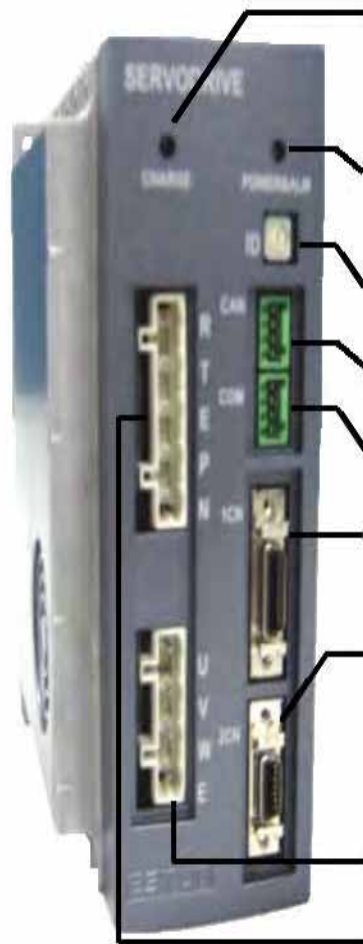

terminal

Charge indicator

It lights on when power is switched on. And it may keep lighting on when power is switched off, since there is some electricity remained in the capacitors.

POWER&ALARM

Green light is on when power is On, and red light is on when servo drive generates an alarm.

CAN COM ID address selection switch

It's available for CAN communication

CAN COM port (CAN)

It's available for CAN communication

RS232 COM port (COM)

Available for communicating with a panel operator or a computer.

I/O signal connector (1CN)

To connect with reference input signal or sequence I/O signal.

Encoder connector (2CN)

To connect with the encoder on the servo motor.

Servo motor connection terminal

The terminal to connect the power cable of servo motor.

Power terminal and regenerative unit connection

Chapter 2 Installation

2.1 Servo motor

Servomotor can be installed either horizontally or vertically. However, if the servomotor is installed with incorrect mechanical fittings, the servo motor's lifetime will be greatly shortened and unexpected accidents will occur.

Please make installation according to the instructions as below:

Precaution:

There's some antirust agent on the edge of the motor shaft to prevent it from rusting during storage. Please wipe off the agent thoroughly by using a cloth dipped with diluting agent or thinner before installing the motor.

NOTE: The diluting agent should not touch any other parts of the servomotor when wiping the shaft.



2.1.1 Storage temperature

When the servomotor is not in use, it should be kept in a place with an environment temperature between -20°C and $+60^{\circ}\text{C}$.

2.1.2 Installation site

Servomotor should be installed indoors, and the environment should meet following conditions:

- Free from corrosive, inflammable or explosive gases
- Well ventilated and free from dust and moisture
- Ambient temperature is between 0°C and 40°C
- Relative humidity is between 26% and 80% RH (non-condensing)
- Maintenance and cleaning can be performed easily

2.1.3 Installation concentricity

Use elastic shaft connectors as many as possible for mechanical connections. The axis centers of servo motor and mechanical load should be kept in the

same line. If a shaft connector is used when installing servo motor, it has to meet the requirement of concentricity tolerance as shown in the illustration below.

Measure this at four quartering positions of a cycle. The difference between the maximum and minimum measured value must be less than 0.03mm. (Rotate together with shaft connectors)

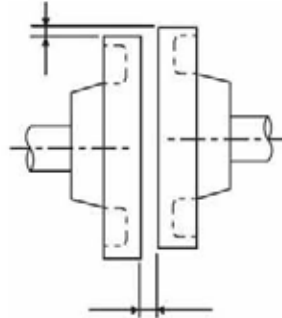

Measure this at four quartering positions of a cycle. The difference between the maximum and minimum measured value must be less than 0.03mm. (Rotate together with shaft connectors)

Note:

If the concentricity tolerance is too big, mechanical vibration will occur, resulting in damage to the bearings of servo motor
Never strike at the axis direction when installing shaft connectors, this could damage easily the encoder of servo motor.

2.1.4 Installation direction

The servomotors can be installed, horizontally, vertically or in any direction.

2.1.5 Handling oil and water

If the servomotor is installed at a location subject to water, oil, or condensation, the motors require special treatment to meet protection requirements. If the motors are required to meet the protection requirement before leaving the factory, it's necessary to designate the exact motor models with oil seal. Shaft through section means the gap as shown in the following picture:

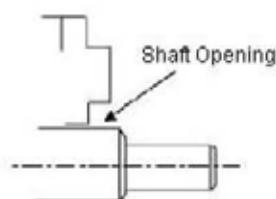

2.1.6 Cable tension

When connecting the cables, the bending radius shouldn't be too small, do not apply big pulling force to cables.

Please be noted in particular that the diameter of signal cable wires is very small, from 0.2 mm to 0.3 mm, therefore handle the cables with adequate care and do not cause excessive cable tension while doing wiring.

2.2 Servo drive

EDC series of servo drives are all base-mounted. Incorrect mounting will definitely cause problems. Always mount the servo drives according to following installation instructions.

2.2.1 Storage condition

When servo drive is not in use, it should be kept in an environment with a temperature between -20 and +85 °C.

2.2.2 Installation site

The notes on installation of servo drive are as below:

Condition	Safety notes
Installed inside a control cabinet	A unified design for the cabinet size, configuration of servo drive, and the cooling method is required so that the ambient temperature around the servo drive is always below 55 °C.
Installed near a heating unit	Minimize the heat radiating from the heating units by taking advantage of heat dissipation measures such as natural convection current, forced-air cooling, to ensure working temperature around the servo drive is always below 55 °C.
Installed near a vibration source	A vibration isolator should be mounted underneath the base surface to prevent vibration.
Installed at a site exposed to corrosive gases	Appropriate measures should be taken to prevent corrosive from getting in. Corrosive gases does not have immediate influence on the servo drive but they will eventually cause problems on electronic components, which will definitely have

	influence on the running stability of servo drive.
Other situations	Do not install the servo drive in hot, humid locations or locations subject to excessive dust or powder in the air.

2.2.3 Installation orientation

As shown in the following picture, the installation direction should be vertically mounted onto the wall, firmly fixed on the surface with two mounting holes.

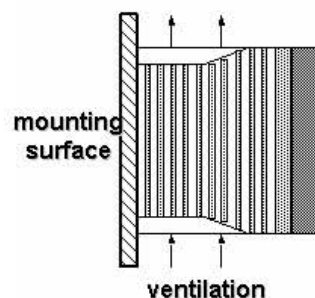

A cooling fan can be mounted for forced-air cooling of the servo drive at request.

2.2.4 Installation of several servo drives

When several servo drives are required to be installed side by side inside one control cabinet, installation must be performed according to the gap requirement as shown below :

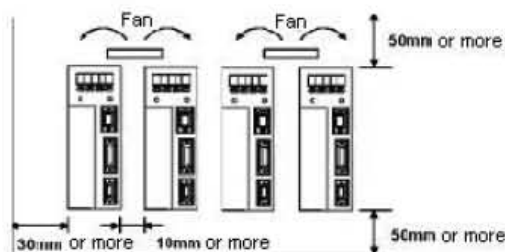

■ Installation orientation

Install the servo drive vertically onto the wall so the front panel(connection board side) of servo drive faces the operator.

■ Cooling

As shown in the illustration above, give sufficient space between each servo

drive so that cooling by cooling fans or natural convection is good.

■ Side-by-side installation

When installing servo drives side by side as shown in the illustration above, reserve at least 10 mm between two horizontal sides and at least 50 mm between two vertical sides. The temperature in the control cabinet needs to be kept evenly distributed, subject to no overheat at any part of servo drive. If necessary, install forced-air cooling fans above the servo drives to avoid excessive temperature rise.

■ Normal Working Conditions for Servo Drive

1. Ambient Temperature: 0 to 55°C
2. Humidity: 90% RH or less, no condensing
3. Vibration: 4.9 m/s² or less

To ensure a long term stability of the drive, it's suggested the drive be used in a place with a temperature below 45 °C.

4) Storage condition

When the servo drive is not in use, it should be kept in a place with an environment temperature between -20°C and +85°C.

Chapter 3 Wiring

3.1 Wiring and connection

Always comply with the following instructions when making wiring or connections.

Notes:

- Neither run power wires and signal wires in the same conduit pipe nor bind them together. There should be at least 30 cm's space between power wires and signal wires.

- Whole shielded twisted pair wires are required for signal wires and encoder feedback wires, shield layer must be connected to the shell of the plugs.

Wire length requirement: reference signal input wires are maximum 3 meters, and encoder feedback wires are 20 meters to the maximum.

- Please be noted that even when the power is turned off, there will still be some electric energy remained in the internal circuit. In order to avoid electrical shock, please make sure inspection or wiring work is started five minutes after Charge indicator is OFF.

- Don't turn power ON and OFF frequently. If required, turning power ON and OFF should be controlled under once a minute.

There are some high capacity capacitors installed in the internal circuit of servo drive, when power is switched on, high charging electric current will flow though the capacitors within several dozen of ms, therefore, frequent power on/off will cause fast aging to servo's internal elements.

3.1.1 Names and Functions of Main Circuit Terminals

Terminal symbol	Function	Description
R, T	Servo drive's power supply input terminal	Single-phase 220VAC(+10% / -15%), 50/60HZ
U, V, W	Servo Motor connection terminals	Connects to power supply terminal of servo motor
E	G grounding terminals	Connected individually to power supply grounding terminals and servo motor grounding terminal.
P, N	Connection terminals of external regenerative unit	To connect an external regenerative unit. Note:

It's prohibited to connect a regenerative resistor directly between P and N.

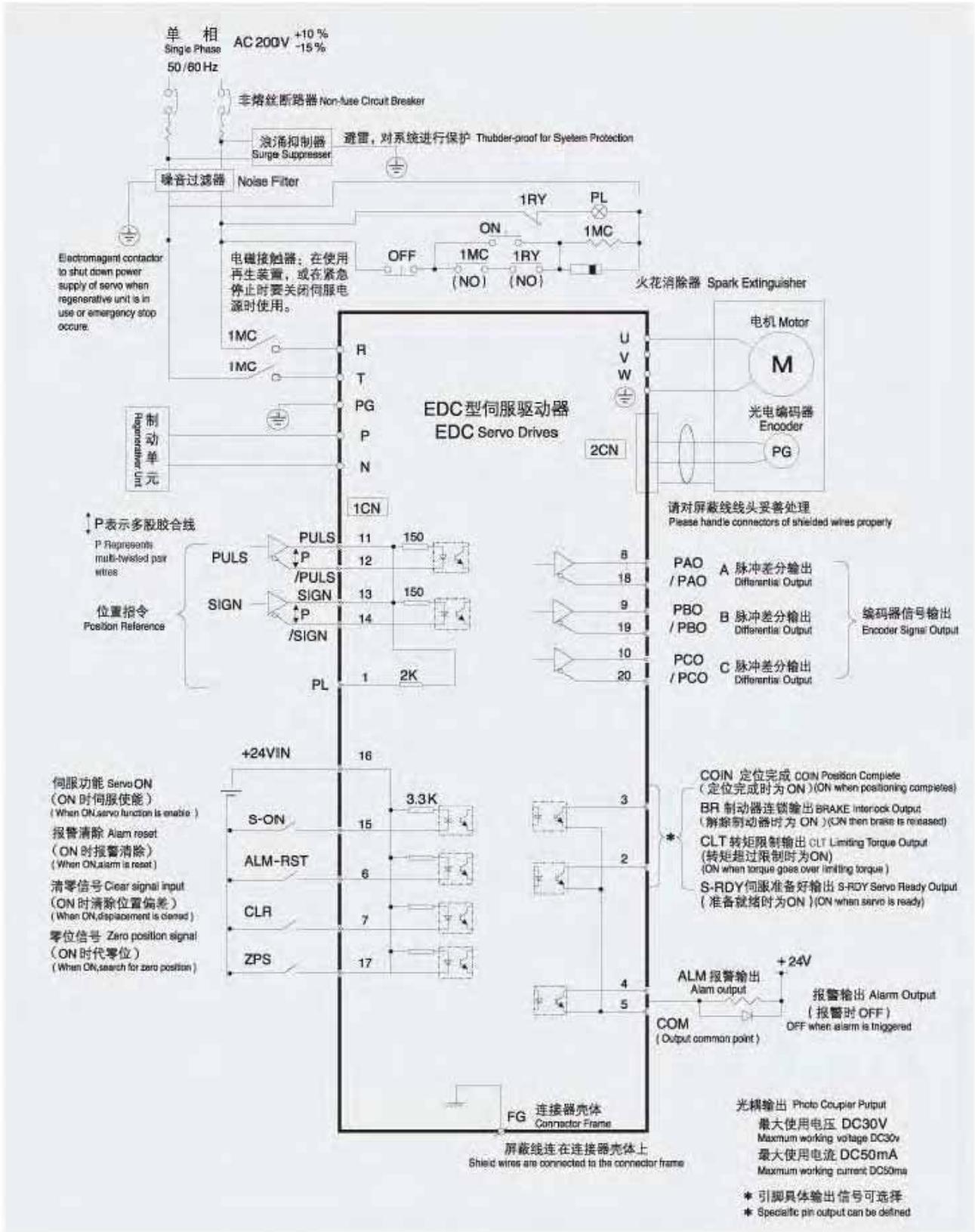

3.2 I/O signals

3.2.1 Standard connection diagram (example)

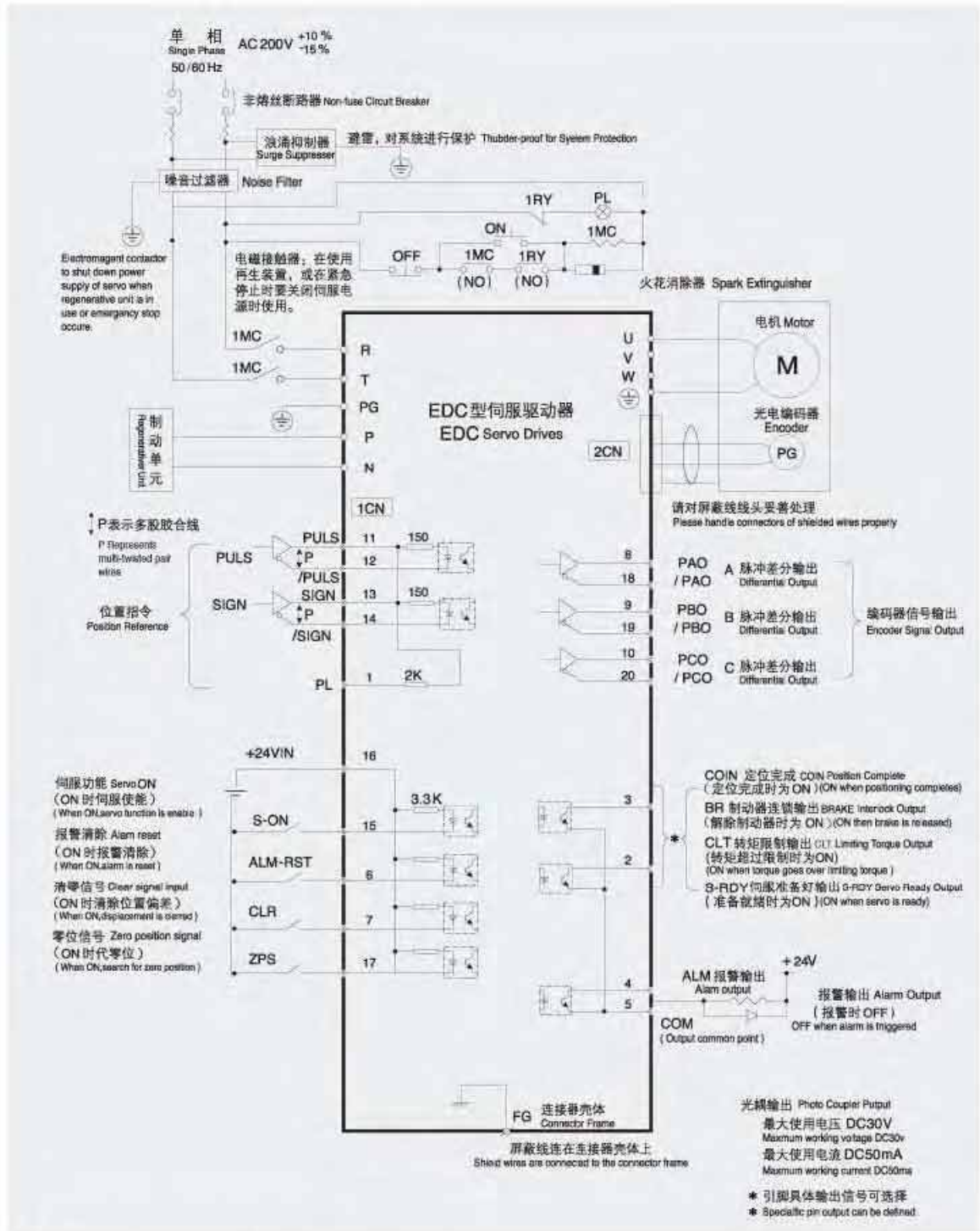

3.2.2 Connector terminals

Terminal no.	Name	Comments	Terminal no.	Name	Comments
1	PL	Power supply for open collector circuit	11	PULS	Reference pulse
2	BRK	Remain braking	12	/ PULS	Reference pulse
3	COIN	Positioning complete	13	SIGN	Reference symbol
4	ALM	Alarm	14	/SIGN	Reference symbol
5	COM	I/O common grounding	15	S-ON	Servo enabled
6	ALM_RST	Reset Alarm	16	+24VIN	I / O power supply
7	CLR	Clear	17	ZPS	Zero position signal
8	PAO	Signal A (difference)	18	/PAO	Signal /A (difference)
9	PBO	Signal B (difference)	19	/PBO	Signal /B (difference)
10	PCO	Signal C (difference)	20	/PCO	Signal /C (difference)
			Shell	FG	Connector's shell

Notices:

1. Spare terminals can not be used for relay purpose.
2. Connect shielded cable wires of I/O signals to connector shell(frame grounding).

3.2.3 Function list of I/O signals

Signal name	Pin number	Function	Reference items
+24VIN	16	Control power supply input for I/O signals: Users need to prepare the +24V power supply. Effective voltage range: +11V ~ +25V	4.2.4
S-ON	15	Servo ON: Servo motor is switched on	4.5.2

ALM-RST/P N-OT	6	According to Bit0 of Pn051: 0: ALM-RST input, which means to reset alarm. 1: limit signal PN-OT input, which means to input mechanical limit signal.		
CLR/PCON	7	According to Bit1 of Pn051: 0: Clear signal input, to clear offset counter during position control. 1: Limit signal PCON input, means different things for different control methods.		4.2.2
ZPS	17	Zero position signal input: zero switch outputs this signal when returning to zero position.		4.1.2
PL	1	Reference open collector power supply: To provide +5VDC power supply when PULS and SIGN reference signals are open collector input signals.		
PULS /PULS SIGN /SIGN	11 12 13 14	Reference pulse input: Line drive or open collector	Input modes: * SIGN + Pulse train * CCW + CW Pulse * 2-phase positive pulse (×4)	4.2.2

■ Output signal (1CN)

Signal name	Pin number	Function	Reference items
ALM	4	Servo alarm: OFF status output is given when the drive detects an error.	4.5.1
COIN	3	The value of Pn050 decides the output signal, see the details as follows: 0: brake interlock(BK) output; positioning complete/same speed detected; in position control method it means positioning is completed(COIN), while in speed control method it means same speed is detected(V-CMP). 1: positioning complete/same speed detected; in position control method it means positioning is completed(COIN), while in speed control method it means	

		<p>same speed is detected(V-CMP)</p> <p>2: torque limit CLT output: when output torque exceeds the value of Pn026 or Pn027, this signal gives output</p> <p>3: Servo ready S-RDY output: When servo drive detects no alarm subject to a power supply input, this signal gives output.</p>	
BRK	2	<p>The value of Pn051 decides the output signal, see the details as follows:</p> <p>0: brake interlock(BK) output;</p> <p>1: positioning complete/same speed detected; in position control method it means positioning is completed(COIN), while in speed control method it means same speed is detected(V-CMP)</p> <p>2: torque limit CLT output: when output torque exceeds the value of Pn026 or Pn027, this signal gives output</p> <p>3: Servo ready S-RDY output: When servo drive detects no alarm subject to a power supply input, this signal gives output.</p>	
COM	5	I/O common grounding	
PAO /PAO	8 18	Differential output of Encoder A signals	
PBO /PBO	9 19	Differential output of Encoder B signals	
PCO /PCO	10 20	Differential output of Encoder C signals	4.5.1
FG	Shell	Connect shielded wires of I/O signal cables to shell of 1CN, that is equal to the connection of the shell and the frame grounding wire.	

3.2.4 Interface circuit example

Following illustrations show the connection of I/O signals of servo drive and host controller:

■ Input interface circuit

Following illustrations show an example of the connection of input signals

using relay contact or open collector transistor circuit.

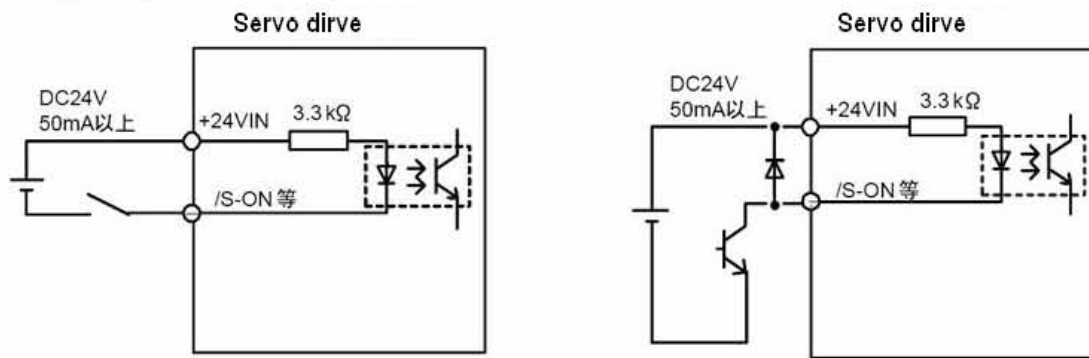

If the relay contact input is used, the relay must be suitable for tiny electric current, otherwise it causes signal receiving faults easily.

■ Interface of encoder output and drive output

Output signals (PAO,/PAO,PBO,/PBO) of the two phase pulse of the encoder, and origin pulse signal(PCO, /PCO) make outputs by means of BUS drive output circuit. Generally, it's used on the condition that the host controller side forms the position control system. Wire reception circuit should be used when it's by the side of host controller.

See "Encoder wiring" for an example of a practical circuit connection.

■ Interface of sequence output circuit

Photo-coupling isolation output is required for output signals of servo alarm, positioning complete and brake interlock.

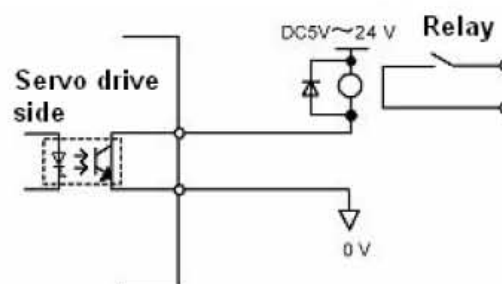

Note:

(1) Maximum voltage should be no more than 30VDC, and maximum current should be no more than 50mA.

3.3 Encoder wiring

3.3.1 Encoder wiring (2CN)

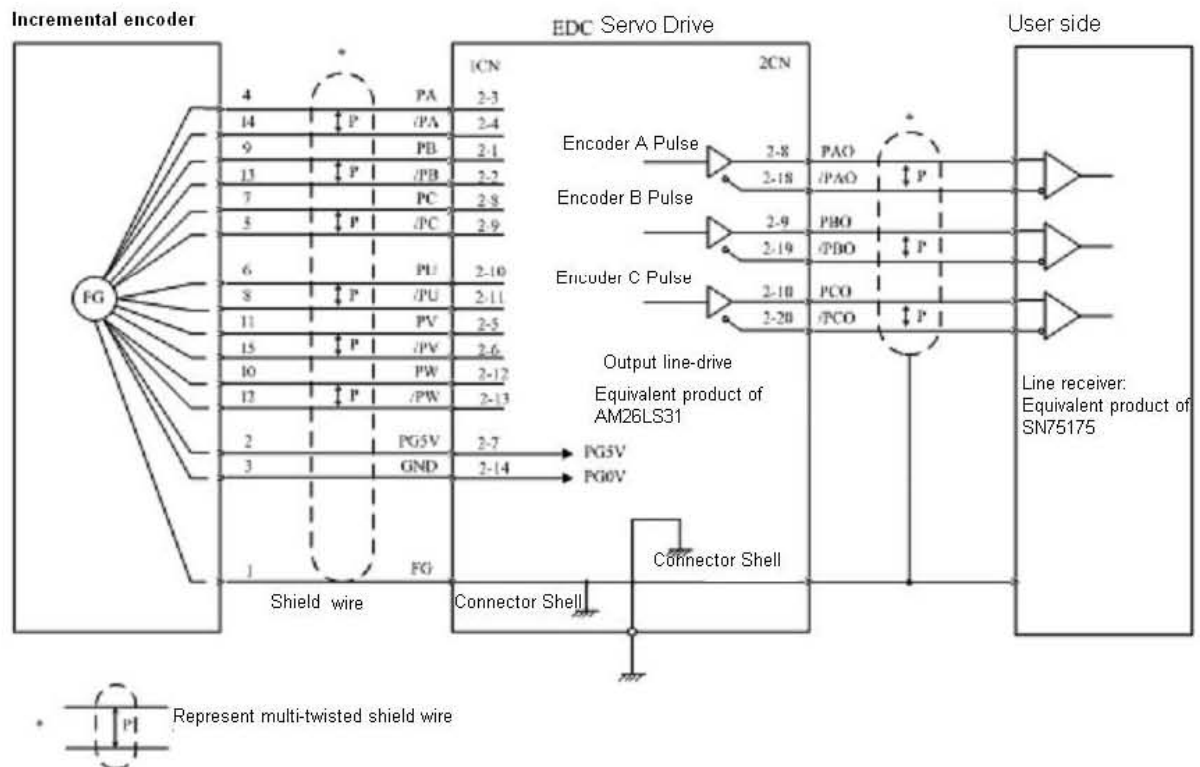

Ps: 1 The sequence No. of encoder pin's corresponding relation with signal will change because of different types of motors.
Please connect the wires according to actual corresponding situation.
2 When the drive connect wire-saving mode encoder motor, just do not connect U,V,W signal

3.3.2 Signal list of connectors (2CN)

See following list for description of 2CN terminals.

Terminal No.	Name	Comments	Terminal No.	Name	Comments
1	PB	Encoder B + Input	8	PC	Encoder C+ input
2	/PB	Encoder B - input	9	/PC	Encoder C- input
3	PA	Encoder A + input	10	PU	Encoder U+ input

4	/PA	Encoder A – input	11	/PU	Encoder U– input
5	PV	Encoder V + input	12	PW	Encoder W+ input
6	/PV	Encoder V – input	13	/PW	Encoder W– input
7	PG5V	Encoder power supply +5V	14	GND	Encoder power supply grounding
				FG	Connect shielded wires to shell of connectors.

Note:

(1) It's suggested overstriking wires or multi-core wires are used for power supply and grounding.

(2) Do not connect the U, V and W signal of a wire-save encoder.

3.4 Motor wiring

3.4.1 Motor encoder terminals

Terminal No.	Comments
1	FG (shield)
2	+5V (power supply)
3	GND (power supply)
4	Channel A output
5	/ Channel A output
6	Channel B output
7	/ Channel B output
8	Channel C output
9	/ Channel C output
10	Channel U output
11	/ Channel U output
12	Channel V output
13	/ Channel V output
14	Channel W output
15	/ Channel W output

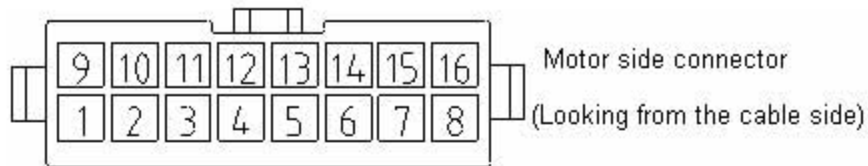

(View from cable side)

Note:

The corresponding relations between pin number of encoder and signal may be different for different types of motors.

Refer to motor instructions.

3.4.2 Motor power terminal

Terminal No.	Comments
1	PE
3	U
2	V
4	W

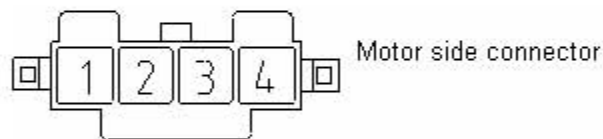

(View from cable side)

Notes:

The corresponding relations between pin number of motor's power wire and signal may be different for different models of motors. Refer to motor instructions.

3.5 Standard connection example

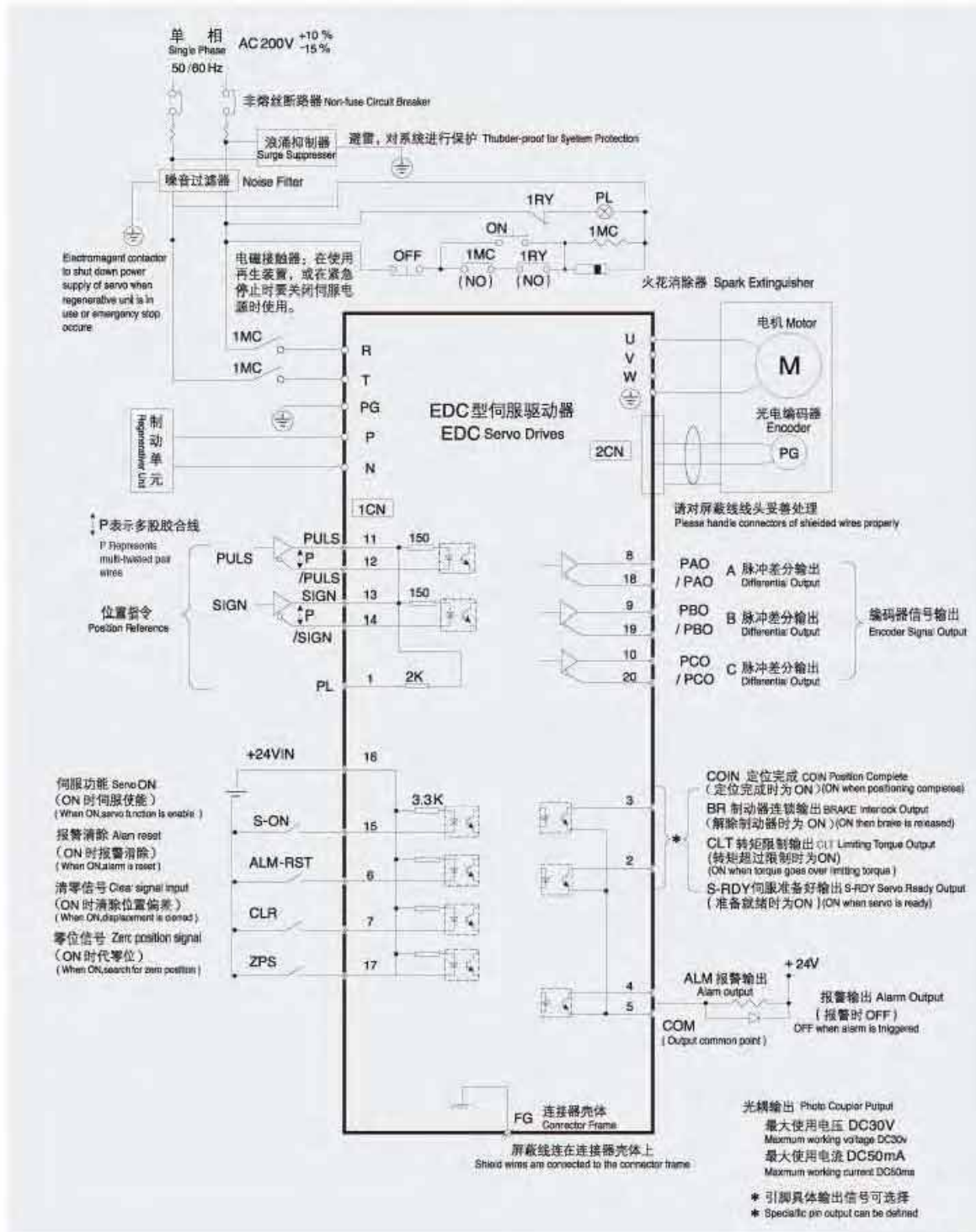

Chapter 4 Function setting and description

4.1 Machine related settings

4.1.1 Servomotor rotation direction Select

With servo drive, a motor can rotate reversely which is called REV mode, with no need to make any changes in motor wiring. The standard setting for “forward rotation” is the counterclockwise as viewed from motor load. REV mode only changes motor’s rotation direction, in this condition, the travel direction(+,-) of shaft reverses, no other changes are made.

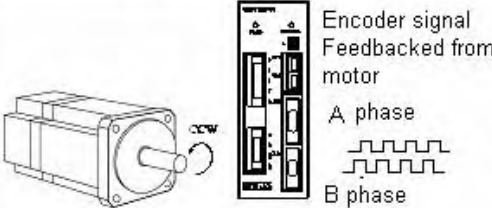
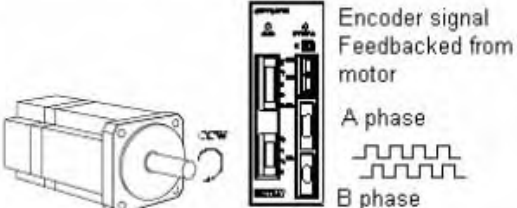
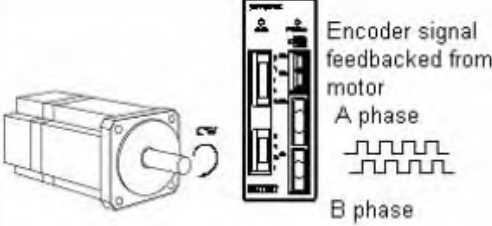
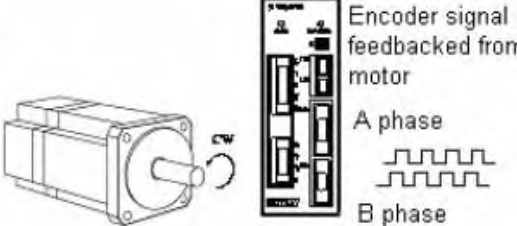
	Standard mode	Reverse mode
FWD Run Reference	 <p>Encoder signal Feedbacked from motor</p> <p>A phase</p> <p>B phase</p>	 <p>Encoder signal Feedbacked from motor</p> <p>A phase</p> <p>B phase</p>
REV Run Reference	 <p>Encoder signal feedbacked from motor</p> <p>A phase</p> <p>B phase</p>	 <p>Encoder signal feedbacked from motor</p> <p>A phase</p> <p>B phase</p>

The encoder signals by motor feedback as shown in above diagrams are the PA,/PA,PB,/PB signals from PG output of servo drive.

■ Set “REV mode”

Rotation direction of motor is selected by setting the parameter as follows.

Para. No..	Name & Comments	Unit	Range	Default
Pn006	Select rotation direction	—	0~1	0

	[0] view from side of motor load, CCW direction represents forward direction. (standard mode)			
	[1] view from side of motor load, CW direction represents forward direction. (REV mode)			

Note:

The change only takes effect when motor power is shut down and re-switched on.

4.1.2 Overtravel

The overtravel limit function forces movable machine parts to stop when they exceed the allowable range of motion.

■ Overtravel function setting

Before using overtravel function, please connect correctly the input signals of following overtravel limit switch to corresponding pin numbers of servo drive's 1CN connector.

→	Input	PN-OT	Pn001=1, Pn052.bit0=1	Forward direction drive is OFF
→	input	PN-OT	Pn001=2, Pn052.bit0=1	Reverse direction drive is ON

EDC servo drive only has one overtravel input signal (1CN-6), so user can only select overtravel limit in single direction. Please be noticed that, when performing first system running, it's required to identify forward and reverse direction before make settings in overtravel parameter.

It's strongly required that user connect the limit switch according to following diagram to avoid possible mechanical damage.

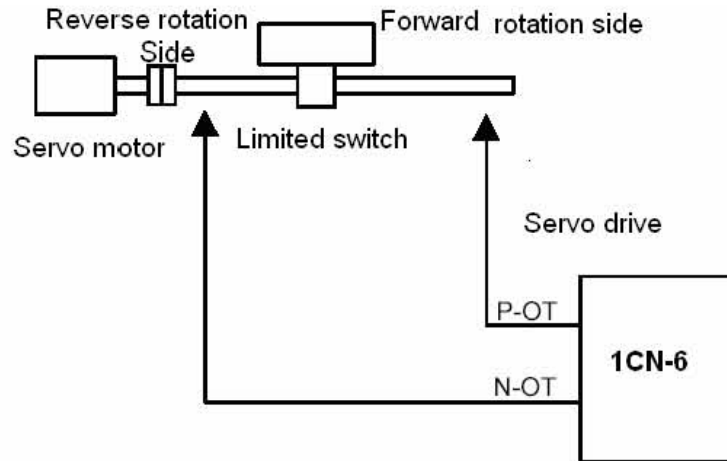

Following table shows the drive status when input signal is ON and OFF.

Signal	Status	Parameter	Input level	Comments
PN-OT	ON	Pn001=1 Pn052.bit0=1	1CN-6 : "L" level	Forward direction driving is allowed. (Normal)
	OFF	Pn001=1 Pn052.bit0=1	1CN-6 : "H" level	Forward direction driving is OFF. (Reverse direction is available)
PN-OT	ON	Pn001=2 Pn052.bit0=1	1CN-6 : "L" level	Reverse direction driving is ON. (Normal)
	OFF	Pn001=2 Pn052.bit0=1	1CN-6 : "H" level	Reverse direction driving is OFF. (Forward direction is available)

■ Switching between Enable/Disable overtravel input signal

By setting the parameter as in following table, user may select Enable or Disable overtravel input signal. Default factory setting is "ON".

Para. No..	Name & Comments	Unit	Range	Default
Pn001	Prohibit input signal ON/OFF (PN-OT) [0] do not use overtravel signal [1] Prohibit forward direction input signal is ON (Forward direction is prohibited when 1CN-6 is OFF, and forward direction is allowed when 1CN-6 is 0V. [2] Prohibit reverse direction input signal is ON	—	0~2	0

	(Reverse direction is prohibited when 1CN-6 is OFF, and reverse direction is allowed when 1CN-6 is 0V.			
--	--	--	--	--

Notes:

1. When motor running is stopped by overtravel in position control mode, there's no pulse lag.
2. Only one overtravel direction can be used, make sure overtravel direction is set before using the function. (subject to actual running)
3. Please be noticed that overtravel signal does not work if motor is running in JOG mode.
4. During mechanical movement, when an overtravel signal occurs, mechanical parts do not stop immediately owing to the action of their own inertia, in this situation, the overtravel signal is canceled and the motor will continue running. Please pay close attention to the duration of overtravel signal, that is, make sure there's some distance for overtravel signal on the machine consideration.

When "P-OT" and "N-OT" are not used, the short circuit wiring as shown in the following diagram will not be required. Another way is to shield this with parameter, use may set Pn001 as 0 or set Pn052.bit=0.

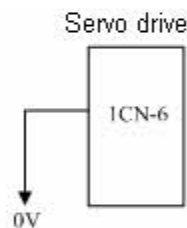

4.1.3 Stop function

■ Select stop mode

When servo is OFF or servo alarm occurs, following "User Constants" should be set according to actual requirements on stopping motor.

Parameter No.	Function	Range	Default
Pn004	Stop modes when servo is on or servo alarm occurs.	0~3	0

Parameter No.	Comments
---------------	----------

Pn004	[0] When servo is OFF or alarm occurs, DB is enabled [1] When servo is OFF or alarm occurs, motor coasts to a stop [2] When servo is OFF or alarm occurs, DB is enabled and will not release until motor stops [3] When servo is OFF or alarm occurs, motor coasts to a stop, then DB is enabled.
-------	--

■ Select motor stop mode when servo is OFF.

EDC series servo drive stop motor running in following situation:

- When /S-ON input signal (1CN-15) turn into OFF
- When alarm is detected
- When power supply is OFF

To select appropriate stop mode, set value of Pn004 according to actual application requirements.

4.1.4 Limiting torque

For protection of mechanical structures, maximum output torque can be limited by setting

following parameters to adjust the maximum value of forward/reverse direction torque on the servo drive.

Para. No.	Name & Function	Unit	Range	Default
Pn026	Forward internal torque limit	1%	0~300	250
Pn027	Reverse internal torque limit	1%	0~300	250

- Set maximum torque for forward and reverse direction, it's used when limiting torque is required according to mechanical requirements.
- If value of current torque exceeds motor's maximum allowable torque, follow the maximum torque of motor.

Example to show protection of mechanical structures

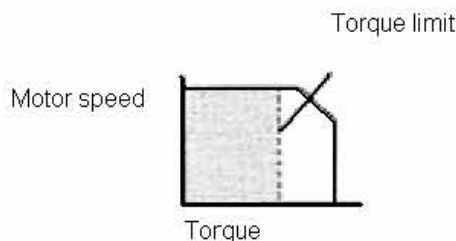

Note:

- It's suggested the value of limited torque not exceed motor's maximum torque.
- If limited value is set too low, motor may have insufficient torque during its acceleration/deceleration.

4.2 Settings complying with host controller

Different control modes can be selected by setting Pn041 as described in following table.

Parameter No.	Name	Range	Default	Comment
Pn041	Select control mode [0] position control [1] internal speed control [2] parameter speed control	0~2	0	position control, position contact control, and parameter speed control

Set Pn041 and select a certain control mode.

Pn041 setting	Control mode
0	Position control (pulse reference) Servo drive receives pulse train generated by host controller, and the control of rotation speed and positioning are achieved according to requirements from host controller.
1	contact speed control (I/O reference) Running at set speed is selected by switch on/off input signals.
2	parameter speed control (parameter reference) Run at constant speed as the value in Pn048.

Way to use CLT signals

Following illustration shows the way to use contact output signal/CLT(torque limit test).

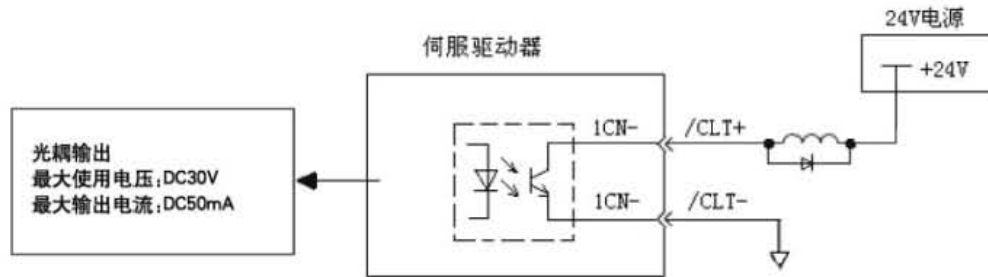

—	>output	Torque limit	Speed control, torque
/CLT		detection output	control, position control

The following signal can be output to indicate the servomotor output torque is being limited or not.

/CLT “L” level when ON	The servomotor output torque is being limited. (internal torque reference is above setting value)
/CLT “H” level when OFF	The servomotor output torque is not being limited. (internal torque reference is below setting value)

The setting value: Pn026 (Forward direction torque internal limit)
Pn027 (Forward direction torque internal limit)

When /CLT signal is used, the output signal and output pin number are required to be defined according to the user constants in following table.

Para. No.	Name & Description	Range	Factory setting
Pn049	Output signal 1CN-2 pin no. signification	0~3	0
Pn050	Output signal 1CN-3 pin no. signification	0~3	1

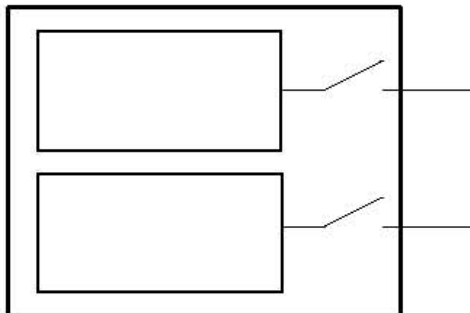

Following table shows the pin number definition for Pn049 (correspond to pin 1CN-2 output), Pn050 (correspond to pin 1CN-3output).

0	BK brake interlock output
1	COIN positioning complete(/V-CMP speed coincidence) output
2	CLT torque limit output
3	S-RDY servo ready output

4.2.1 Position control

In position control mode(Pn041=0), servo drive make driving servo motor run according to position reference given by host controller. It is required to select optimal style from varies styles according to requirements of host control device.

■ Pulse input

Host device controls the rotation speed and position of servo system by sending a series of pulse trains.

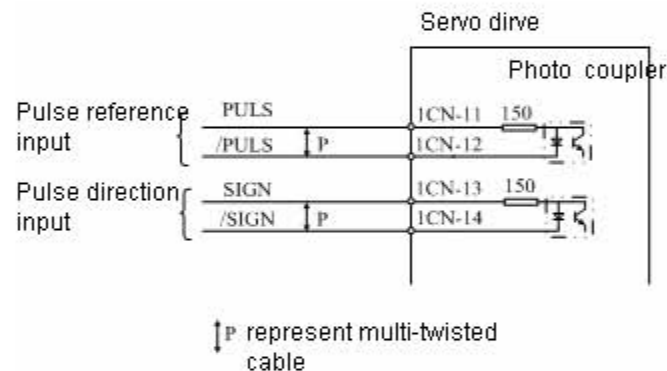

Host control device may give three types of pulse reference as follows:

- linear driving output
- +24V open collector output
- +12V and +5V open collector output

Connection example 1 (when host controller is linear driving output)

Applicable linear drives (T1 company AM26LS3, SN75174 or MC3487 and other substitutes.)

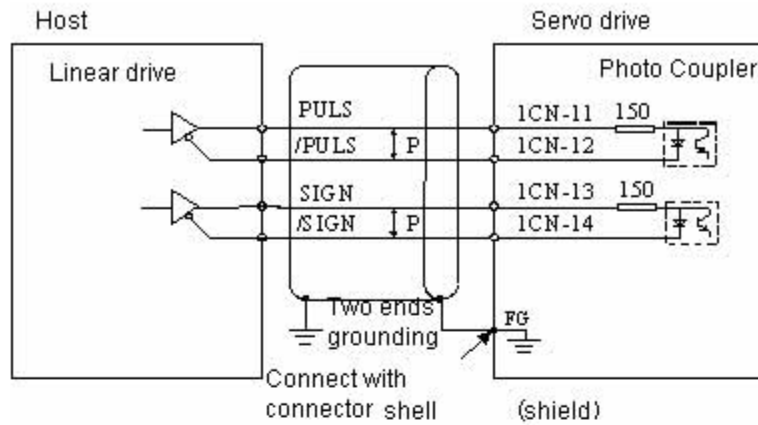

Example 2 (When host device is open collector output subject to 24VDC signal power)

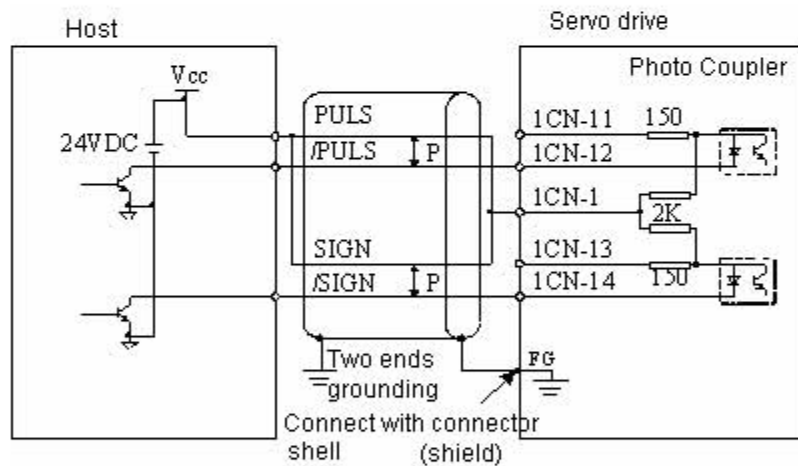

Example 3 (When host device is open collector output subject to 12VDC or 5VDC signal power)

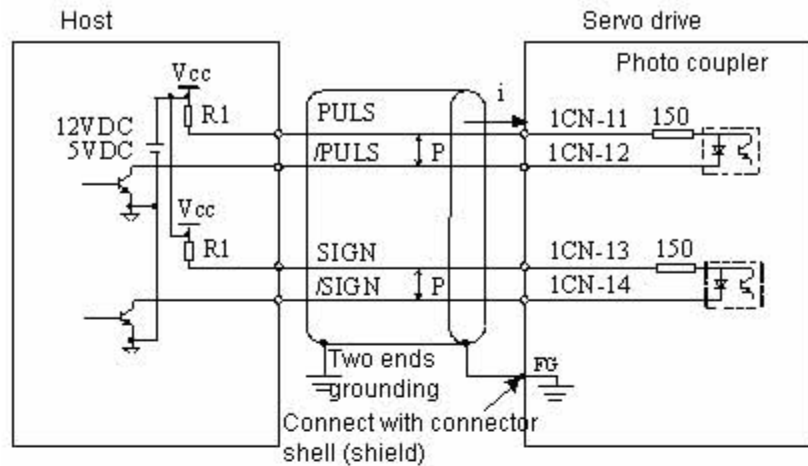

The right current limiting resistor R1 should be used according to current requirements ($i = 10\sim 15\text{mA}$) :

When Vcc is 12V, $R1=560\sim 820\Omega$

When Vcc is 5V, $R1=82\sim 200\Omega$

■ Select reference pulse mode

·input 1CN-11	PULS	input reference pulse
·input 1CN-12	/PULS	input reference pulse
·input 1CN-13	SIGN	input reference sign
·input 1CN-14	/SIGN	input reference sign

Use parameter "Pn008, Pn009" to select " reference pulse mode"

Parameter	Code	Comments	Unit	Range	Factory setting
Pn008	--	input pulse mode: [0]SIGN + pulse [1]CW+CCW [2]A+B(perpendicular × 4)	--	0~2	0

Pn008	--	Inverts input pulse [0]:does not invert pulse reference [1]:inverts pulse reference	-	0~1	0
-------	----	--	---	-----	---

Following are available reference pulse styles, please make the setting according to specification of host controller.

Pn008	Reference style	servomotor forward run reference	servomotor reverse run reference
0	Sign + pulse train		
1	CW pulse + CCW pulse		
2	2 phase perpendicular pulse		

User may select to invert input signal or not by setting Pn009 according to actual requirements.

PULS
(1CN-11)

SIGN
(1CN-13)

“H”

PULS
(1CN-11)

“L”

■ Pulse input sequence

Input of pulse reference must meet following conditions on level and sequence.

SIGN
(1CN-13)

PULS
(1CN-11)

SIGN
(1CN-13)

Time for "reference pulse input"

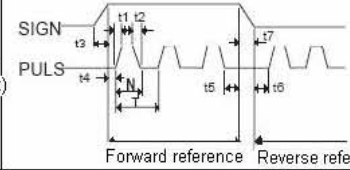
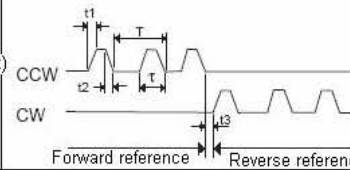
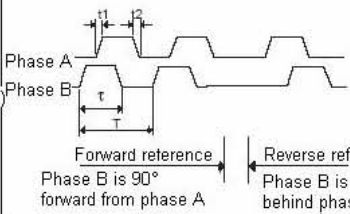
Reference Pulse signal Form	Electrical Specifications	Remarks
Sign + pulse train input (SIGN + PULS signal) Max. reference frequency: 500 kpps (when 200kpps collector open output)	 <p>Forward reference Reverse reference</p> <p> $t_1, t_2 \leq 0.1\mu s$ $t_3, t_7 \leq 0.1\mu s$ $t_4, t_5, t_6 > 3\mu s$ $\tau \geq 1.0\mu s$ $(\tau/T) \times 100 \leq 50\%$ </p>	Sign H = Forward reference L = Reverse reference
CCW pulse + CW pulse Maximum reference frequency: 500 kpps (when 200kpps collector open output)	 <p>Forward reference Reverse reference</p> <p> $t_1, t_2 \leq 0.1\mu s$ $t_3 > 3\mu s$ $\tau \geq 1.0\mu s$ $(\tau/T) \times 100 \leq 50\%$ </p>	
90° different two-phase pulse train (phase A + phase B) Maximum reference frequency x 4 multiplier: 200 kpps	 <p>Forward reference Reverse referre</p> <p>Phase B is 90° forward from phase A Phase B is 90° behind phase A</p> <p> $t_1, t_2 \leq 0.1\mu s$ $\tau \geq 1.0\mu s$ $(\tau/T) \times 100 = 50\%$ </p>	

■ Clear error counter

Follow the steps below to clear "Error counter".

→input **CLR 1CN-7** Clear error counter input

When CLR signal is Low level, error counter is cleared.

Way to clear error counter:

- Servo drive's internal error counter is zero(0).
- This signal means "power level active", it's required to retain some time before the signal takes effect. The signal has to be canceled after pulse is cleared, otherwise, the counter is always in the zero Clear status, which will result in no action of servo position loop.

In position control mode, some pulse will remain in error counter when servo is OFF. Therefore, the error counter has to be cleared immediately after servo is re-enabled. With Pn005 setting, pulse signal of error counter can be cleared automatically when servo is OFF.

Parameter No.	Name and comments	Setting range	Factory setting
Pn005	0: When S-OFF, clear error counter 1: When S-OFF, does not clear error counter	0~1	0

■ position reference 1st filter time

- position reference 1st filter can improve system's respond smoothness to given reference pulse.
- If reference input is comparatively rough, the dividing frequency multiplication is set too large or frequency of pulse input is low, which can implement more smoothly controlling of servo system.
- If position reference 1st filter time constant (that is Pn024) is set too large, servo system's dynamic performance will be depressed.

Parameter No.	Name	Unit	Setting range	Factory setting
Pn024	position reference 1st filter time constant	ms	0~1000	0

4.2.2 Encoder signal output

EDC servo drive outputs pulse signal of encoder A/B/C, which facilitate using of host controller.

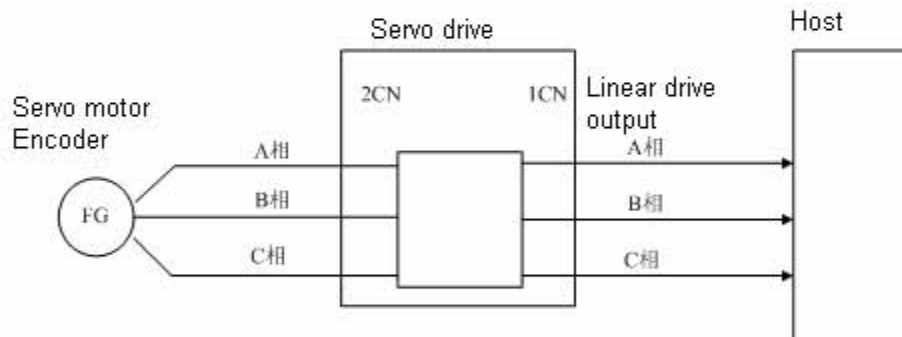

Output circuit is bus drive output. Make circuit connection with reference to following circuit.

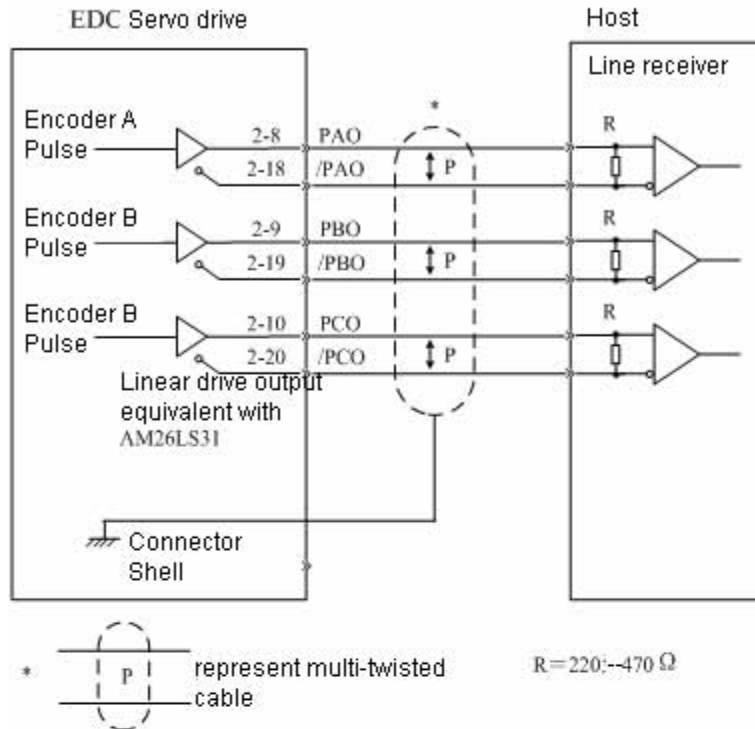

■ **Output signal**

Output encoder signal after frequency is divided.

Output	▷ PAO	1CN- 8	A phase pulse
Output	▷ /PAO	1CN- 18	differential Output
Output	▷ PBO	1CN- 9	B phase pulse
Output	▷ /PBO	1CN- 19	differential Output
Output	▷ PCO	1CN- 10	C phase pulse
Output	▷ /PCO	1CN- 20	differential Output

The following illustration shows the style of perpendicular pulse output of Phase A and Phase B .

Parameter Pn011=0:

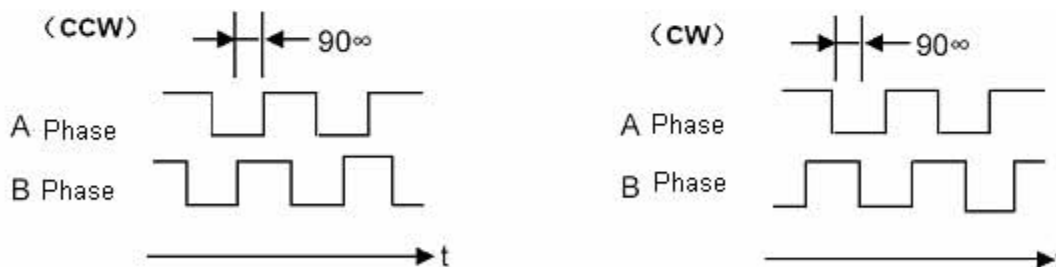

Parameter Pn011=1:

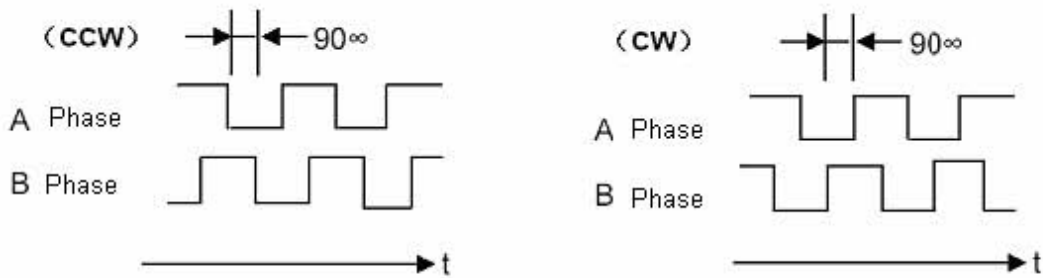

■ Set pulse dividing frequency ratio

Set pulse dividing frequency ratio with following parameters.

Parameter	Meaning	Unit	Range	Factory setting
Pn010	Set PG dividing frequency ratio	2500P/R	1~2500	2500
Pn011	Inverts dividing frequency output phase		0~1	0

Set output pulse numbers of PG output signal (PAO /PAO,PBO,/PBO) which is transmitted outward subject to servomotor runs for one revolution.

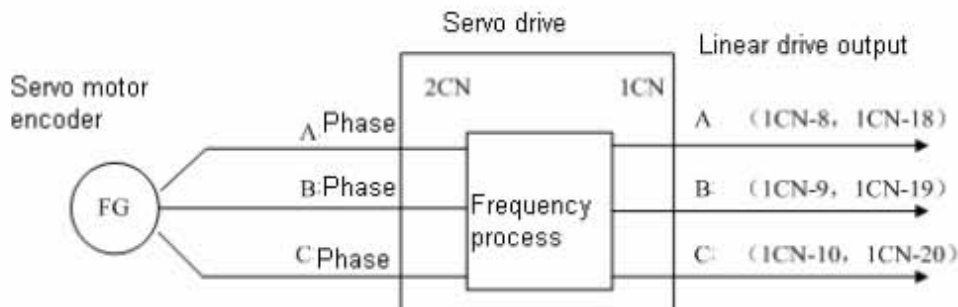

Divide pulse frequency of servomotor encoder(PG) and output according to pulse number setting.

Setting value means the individual output of pulse numbers for PAO, /PAO, PBO and /PBO signal when servomotor runs for one revolution. If Pn010 is set as 1000, it means output of PAO signal is 1000 pulses subject to motor runs for one revolution, so do the /PAO, PBO and /PBO signal output.

Please make setting according to machine and reference unit of controller.

Note:

- After parameter changing, turn power OFF and then turn power ON again.

4.2.3 Sequence I/O signal

To control sequence input and output signal of servo drive's movement , please connect according to demand.

■ Connect sequence input signal

Following illustration shows how to connect sequence input signal.

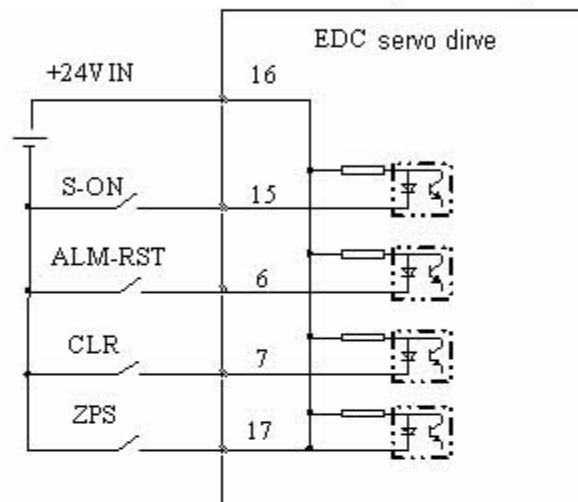

Notes:

- **24V I/O power supply is required, since there is no internal power supply servo drive.**
- External power supply specification: DC24V±1V, 500mA higher.
- It's suggested that input circuit and output circuit use the same power supply.
- Voltage range of input circuit is +11V~+25V. If power voltage is low and mechanical joints like relay is used , micro current switch or relay are required to avoid bad contact. Always check and confirm the electrical specification of the relay or relevant parts before starting to use.

9	input +24VIN 1CN-	External I/O power input
---	-------------------	--------------------------

■ Connect contact point of output signal

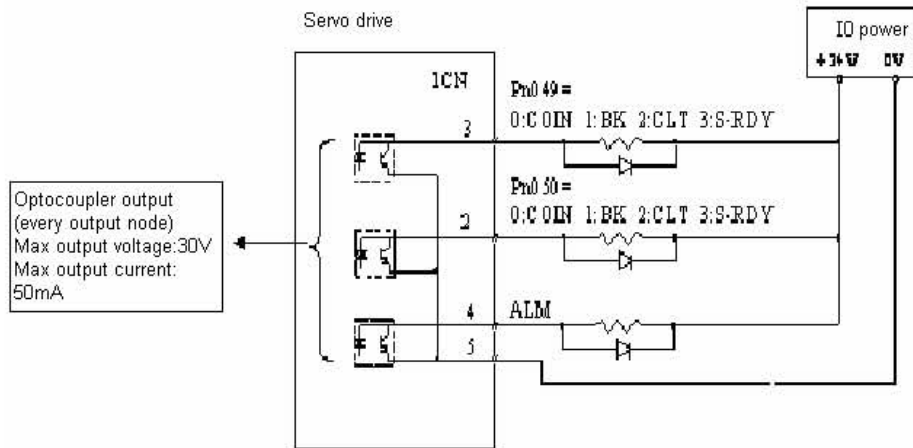

■ Handling I/O signal

Input signal is smoothed with filter and then received by servo drive. Set filter time with parameter Pn053. Active power level of input signal is controlled by Pn054, and active power level of output signal is controlled by Pn055.

Following signals are I/O signals subject to default parameters.

Parameter no.	Name and meaning	Unit	Setting range	Factory setting
Pn053	input signal filter time	ms	0~1000	100
Pn054	Inverts input signal	—	0~63	0
Pn055	Inverts output signal	—	0~7	0

During filter time of input signal, if signal jump occurs, input signal will not be received by servo drive. Input signal will be received by drive only after it keeps stable for the set time, that is, signal needs to keep on constant level within period of Pn053 before it can be accepted by servo drive. Drive estimates signal validity according to Pn054.

Following table shows operations to invert input signal (Pn054).

Digit	BIT3		BIT2		BIT1		BIT0	
input signal	ZPS		CLR		ALM-RST		S-ON	
Signal level	H	L	H	L	H	L	H	L
Pn054	0	1	0	1	0	1	0	1

Signal active	N	Y	Y	N	N	Y	Y	N	N	Y	Y	N	N	Y	Y	N
--------------------------	---	---	---	---	---	---	---	---	---	---	---	---	---	---	---	---

In above table,

"H": it means input signal is at high level.

"L": input signal is at low level.

"0": setting value in Pn054. "0" means input signal low is active.

"1": setting value in Pn054. "1" means input signal high is active.

"N": input signal is inactive.

"Y": input signal is active.

For example: if CLR at high level and all the rest of signals at low level are required to be active, then it is expressed as 000100 in binary system, it will be 4 if converted into decimal system, that is, Pn054 must be set as 4.

Take similar operation steps to set Output signal.

Digit	BIT2				BIT1				BIT0			
Output Meaning	BRK				COIN				ALM			
Signal meaning	Release braking		braking		arrive		Not arrive		alarm		No alarm	
Pn055	0	1	0	1	0	1	0	1	0	1	0	1
Output Level	low	high	high	low	low	high	high	low	high	low	low	high

Note:

When ALM is in normal status, Output level is high, inverts other two signal.

For example:

If output level is required to meet following conditions:

- high when braking signal releases braking
- low when COIN signal is active
- ALM output is high when alarm occurs

then it will be expressed as 100 in binary system, if it is converted into decimal system it would be 4, that is, Pn055 should be set as 4.

Note:

- The validity of I/O signals mentioned in this manual are all referring to normal situation, that is, active when input signal is at low level, active when BRK、COIN output is at low level, ALM output is at high level.
-

4.2.4 Electronic gear

With “Electronic gear” function, workpiece movement which is equivalent to input reference pulse can be set to any value. Host controller that sends reference pulse can implement control operation with no need to care for mechanical gear ratio and pulse number of encoder, so control calculation becomes easier.

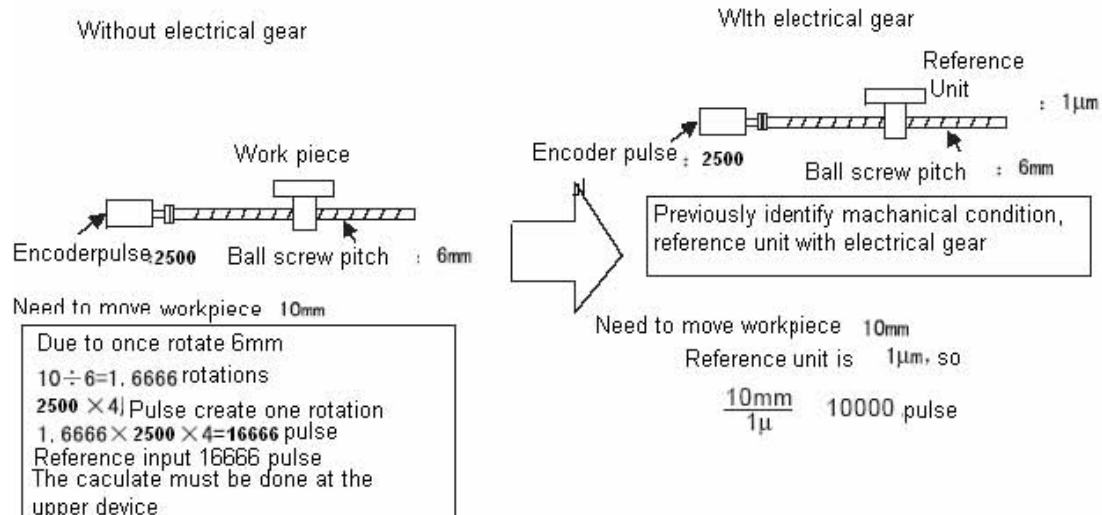

■ Way to set electronic gear

Take following steps to calculate electronic gear ratio (B/A), and its value is set in Pn022 and Pn023 of user parameter.

1. Mechanical forms related to electronic gear
 - gear ratio
 - ball bearing screw pitch
 - pulley radius
2. Encoder pulse number of servo motor
3. Equivalent pulse (reference unit)

Reference unit refers to the unit of minimum moving distance required by load or the minimum reference unit of host controller.

Reference move the worktable by 0.001mm unit

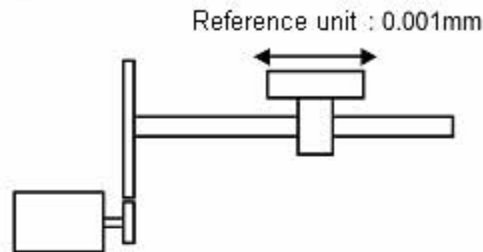

Please decide the the reference unit by mechanical form and position precision

For example, reference unit can be 0.01mm, 0.001mm, 0.1°, 0.01 inch, reference of input one pulse, the distance or angle of moving a pulse equivalent.

If pulse equivalent is 1μm, input reference pulse 50000, then moving distance will be 50000×1μm=50mm

4. With pulse equivalent, load moving distance is calculated subject to load shaft revolves for one revolution.

Moving distance of load (reference unit)= Moving distance of load / pulse equivalent.

If ball bearing screw pitch is 5mm, pulse equivalent is 0.001mm, 5mm/0.001mm = 5000 (reference unit)

Ball screw	Rotating table	Belt roller
<p>Reference unit = $\frac{p}{1}$</p>	<p>Reference unit = $\frac{360^\circ}{1}$</p>	<p>Reference unit = $\frac{\pi D}{1}$</p>

5. Solve for electronic gear ratio(B/A)

Gear ratio of motor shaft and load shaft is n/m. (Motor revolves for m revolutions, load shaft revolves for n revolutions).

Electronic gear ratio (B/A) = [(encoder pulse number × 4) / moving distance when load shaft finishes one revolution] × (m/n)

It's suggested the electronic gear set within following range:

$$0.01 \leq \text{electronic gear ratio (B/A)} \leq 100$$

6. Set parameter

Make reduction of (B/A) to get A and B, and select most proximal whole number which is lower than 32767.

Thus, setting of electronic gear ratio is completed.

Parameter	Name	Uni	Range	Factory
-----------	------	-----	-------	---------

		t		setting
Pn022	electronic gearB (numerator)	--	1~32767	1
Pn023	electronic gearA (denominator)	--	1~32767	1

Electronic gear ratio (B/A) = Pn022 / Pn023

·B = "Encoder pulse number × 4" × "rotation speed of motor shaft"

·A = reference pulse number of each unit (load movement when load shaft finishes one revolution) × " rotation speed of load shaft"

■ Setting example of electronic gear

The following illustrations show the settings for varies kinds of mechanical structures.

Belt + Pulley

Reference
Unit : 0.02mm

Bearing shaft

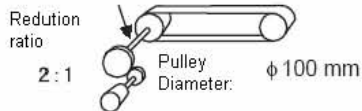

Incremental encoder:
2500P/R

Load movement amount of bearing shaft's one round rotation = $\frac{3.14 \times 100 \text{ mm}}{0.02 \text{ mm}} = 15700$

Electrical gear ratio

$$\left(\frac{B}{A}\right) = \frac{2500 \times 4 \times 2}{15700 \times 1} = \frac{\text{Pn022}}{\text{Pn023}}$$

$$= \frac{200}{157}$$

Setting Value	Pn022	200
	Pn023	157

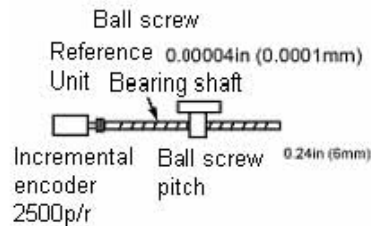

Load movement amount of bearing shaft one round rotation = $\frac{6\text{mm}}{0.0001\text{mm}} = 60000$

$$\text{Electrical gear ratio} = \left(\frac{B}{A}\right) = \frac{2500 \times 4 \times 1}{60000} = \frac{\text{Pn022}}{\text{Pn023}}$$

Setting Value	Pn022	1
	Pn023	6

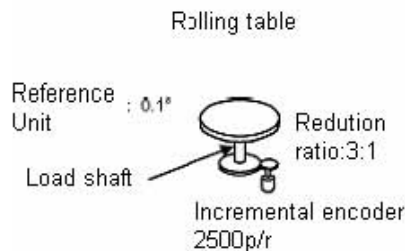

Load movement amount of bearing shaft one round rotation = $\frac{360^\circ}{0.1^\circ} = 3600$

$$\text{Electrical gear ratio} = \left(\frac{B}{A}\right) = \frac{2500 \times 4 \times 3}{3600} = \frac{\text{Pn022}}{\text{Pn023}}$$

Setting Value	Pn022	75
	Pn023	9

■ Dynamic electronic gear

If system pulse frequency is low and only one electronic gear is used, it's hard to give consideration to both processing efficiency and position resolution. Therefore, EDC servo has a second electronic gear numerator, and both can be switched dynamically.

In position control mode (Pn041=0), after 2nd electronic gear is enabled (Pn056=1), dynamic electronic gear becomes active. Switching electronic gear requires PCON signal (input signal select Pn051's bit1=1).

It's better to switch electronic gear without any pulse input, otherwise pulse loss may occur. Since electronic gear will not switch until there's no pulse input within 1ms. Numerator of electronic gear after switching is the value of Pn056.

The sequence is as shown below.

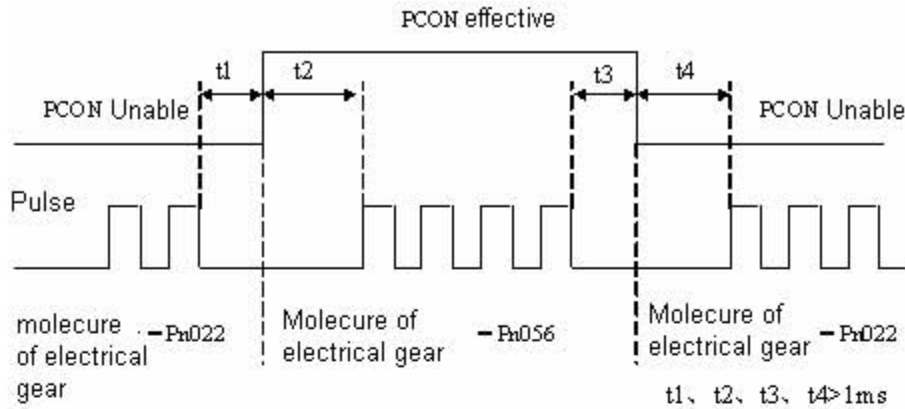

■ Position control diagram

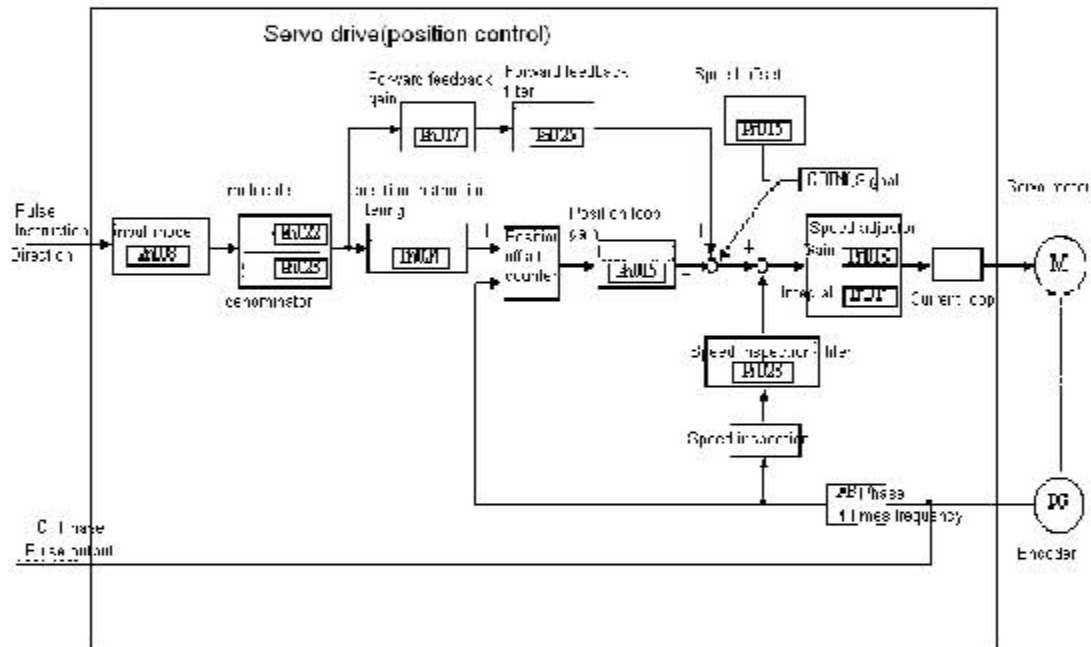

4.2.5 Position contact control

Reference of position control (control mode parameter Pn041=0) comes from pulse input of host controller. Reference of internal speed control (control mode Pn041=1) comes from internal parameter value (Pn080~Pn095) of servo drive.

Parameter (Pn080, Pn081) ~ (Pn094, Pn095) are the internal eight groups of position reference register. Programming method can be defined according to Pn070. There are two method: (a) incremental; (b) absolute. It can also

co-operate with external I/O(1CN-7 input as PCON signal).

■ **Setting of position contact control**

1. Set Pn041=1 (internal speed control);
2. Select cycle run or not, whether PCON is used as step change signal or not, programming method, start and stop point of program, etc.

Parameter number	Name and meanings	Setting range	Factory setting	Other
Pn068	Select cycle run [0] multiple cycle run [1] multiple single run	0~1	0	
Pn069	Enable/Disable PCON signal as step change signal [0] delay step change [1] PCON signal step change	0~1	0	When PCON signal is used as step change: 1. BIT1 of Pn051 is required to be set as 1. 2. PCON active is generated at the edge of input signal from inactive to active.
Pn070	Programming method [0] incremental [1] absolute	0~1	0	
Pn072	Start point of program	0~7	0	Which of the 8 groups of position data is used as start point.
Pn073	Stop point of program	0~7	1	Which of the 8 groups of position data is used as stop point.

3. Required moving distance of motor is calculated according to actual moving distance, then moving distance data is filled in each contact position register.

Parameter Number	Name and meanings	Unit	Setting range	Factory setting
Pn080	moving distance 0 revolution	10 ⁴ reference pulse	-30000~30000	0
Pn081	moving distance 0	1 reference pulse	-9999~9999	0

Pn082	moving distance 1 revolution	1	10 ⁴ reference pulse	-30000~3000 0	0
Pn083	moving distance 1 low		1 reference pulse	-9999~9999	0
Pn084	moving distance 2 revolutions	2	10 ⁴ reference pulse	-30000~3000 0	0
Pn085	moving distance 2 low		1 reference pulse	-9999~9999	0
Pn086	moving distance 3 revolutions	3	10 ⁴ reference pulse	-30000~3000 0	0
Pn087	moving distance 3 low		1 reference pulse	-9999~9999	0
Pn088	moving distance 4 revolutions	4	10 ⁴ reference pulse	-30000~3000 0	0
Pn089	moving distance 4 low		1 reference pulse	-9999~9999	0
Pn090	moving distance 5 revolutions	5	10 ⁴ reference pulse	-30000~3000 0	0
Pn091	moving distance 5 low		1 reference pulse	-9999~9999	0
Pn092	moving distance 6 revolutions	6	10 ⁴ reference pulse	-30000~3000 0	0
Pn093	moving distance 6 low		1 reference pulse	-9999~9999	0
Pn094	moving distance 7 revolutions	7	10 ⁴ reference pulse	-30000~3000 0	0

Set parameters like run speed, acceleration/deceleration time, stop time, and so on according to field working situation.

Parameter No.	Name and meanings	Unit	Setting range	Factory setting
Pn096	moving distance 0 speed	r/min	0~3000	500
Pn097	moving distance 1 speed	r/min	0~3000	500
Pn098	moving distance 2 speed	r/min	0~3000	500

		n		
Pn099	moving distance 3 speed	r/min	0~3000	500
Pn100	moving distance 4 speed	r/min	0~3000	500
Pn101	moving distance 5 speed	r/min	0~3000	500
Pn102	moving distance 6 speed	r/min	0~3000	500
Pn103	moving distance 7 speed	r/min	0~3000	500
Pn104	moving distance 0 first(1st) acceleration/deceleration time constant	ms	0~32767	0
Pn105	moving distance 1 first(1st) acceleration/deceleration time constant	ms	0~32767	0
Pn106	moving distance 2 first(1st) acceleration/deceleration time constant	ms	0~32767	0
Pn107	moving distance 3 first(1st) acceleration/deceleration time constant	ms	0~32767	0
Pn108	moving distance 4 first(1st) acceleration/deceleration time constant	ms	0~32767	0
Pn109	moving distance 5 first(1st) acceleration/deceleration time constant	ms	0~32767	0
Pn110	moving distance 6 first(1st) acceleration/deceleration time constant	ms	0~32767	0
Pn111	moving distance 7 first(1st) acceleration/deceleration time constant	ms	0~32767	0
Pn112	moving distance 0 stop	50m	0~30000	10

	time	s		
Pn113	moving distance 1 stop time	50m s	0~30000	10
Pn114	moving distance 2 stop time	50m s	0~30000	10
Pn115	moving distance 3 stop time	50m s	0~30000	10
Pn116	moving distance 4 stop time	50m s	0~30000	10
Pn117	moving distance 5 stop time	50m s	0~30000	10
Pn118	moving distance 6 stop time	50m s	0~30000	10
Pn119	moving distance 7 stop time	50m s	0~30000	10

4. After Servo ON, position contact runs.

Position contact control is like single contact position controller, user can make cycle run operation easily with this function.

As for Pn070, for example, position reference P0($Pn080 \times 10000 + Pn081$) is ten revolutions, position reference P1($Pn082 \times 10000 + Pn083$) is thirty revolutions, when running from P1 to P2, the difference between incremental type and absolute type is as below:

Note:

1. In position contact control mode, electronic gear does not work, which can be regarded as the electronic gear ratio is always 1: 1.
 2. In position contact control mode, all the position control parameters will affect motor running, such as position proportional gain Pn015, feed forward Pn017, position first filter Pn024, feed forward filter Pn025, etc.
-

4.2.6 Zero adjustment

In position control mode, servomotor is often required to run at a fixed position, this position is normally regarded as Zero position. Some times, after host controller is energized, zero position adjustment is required before processing operation. After that, this position will be regarded as the reference point for every subsequent running. The zero position adjustment can be done with servo drive.

■ Parameter setting for zero adjustment

1. Select zero adjustment according to practical application.

Parameter number	Name and meanings	Unit	Setting range	Factory setting
Pn071	Return method of origin Z Y X Z=0: disable origin return function Z=1 : origin return starts automatically only after first S-ON Z=2 : origin return starts automatically every time S-ON Y=0: search Pulse C after origin has returned Y=1: does not search Pulse C after origin has returned X=0: origin returns at forward run direction X=1: origin returns at reverse run direction	—	0~211	0

2. Set zero adjustment speed

Parameter number	Name and meanings	Unit	setting range	Factory setting
Pn074	Speed 1 during reference searching (hit position limit switch)	r/min	0~3000	1000
Pn075	Speed 3 during reference searching(after releasing position limit switch)	r/min	0~3000	5
Pn077	Origin return offset revolution	1000 0 pulse	9999	0
Pn078	Origin return offset pulse number	1 pulse	9999	0

3. Comments

When zero adjustment method is selected according to practical requirements(set Pn071), zero adjustment will be implemented according to setting.

When zero adjustment is started, servomotor will run at the set speed of Pn074.

When ZPS(1CN-17) signal is active, if the parameter setting requires the servo motor to return and search Pulse C, then motor will run reverse at the set speed of Pn075, otherwise, motor will run forward at the set speed of Pn075.

When ZPS signal is inactive, after first Pulse of motor encoder is detected, calculation of zero balance offset pulse is started, motor stops after offset pulse completes. Zero adjustment operation is completed. Motor will not return and search Pulse C after it hits the zero adjustment position limit switch.

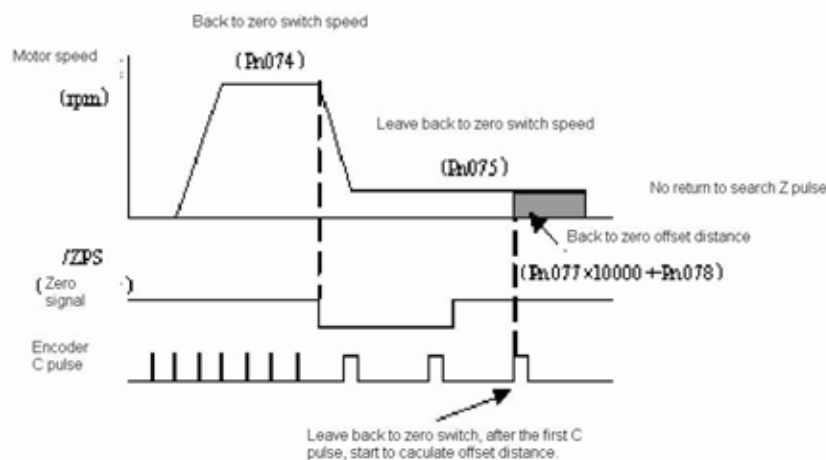

Corresponding position:

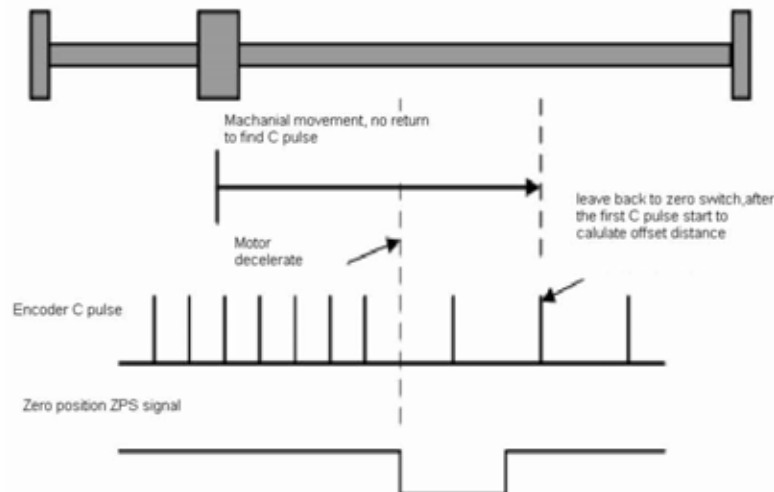

Return and search Pulse C after touching zero adjustment switch:

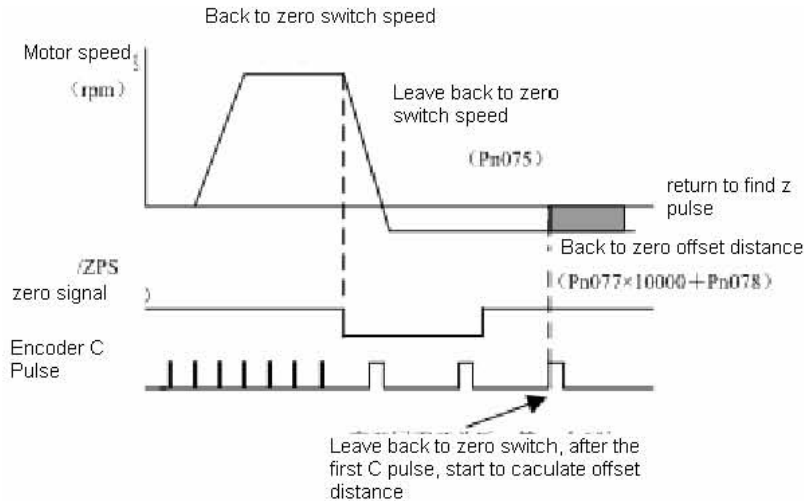

Corresponding position:

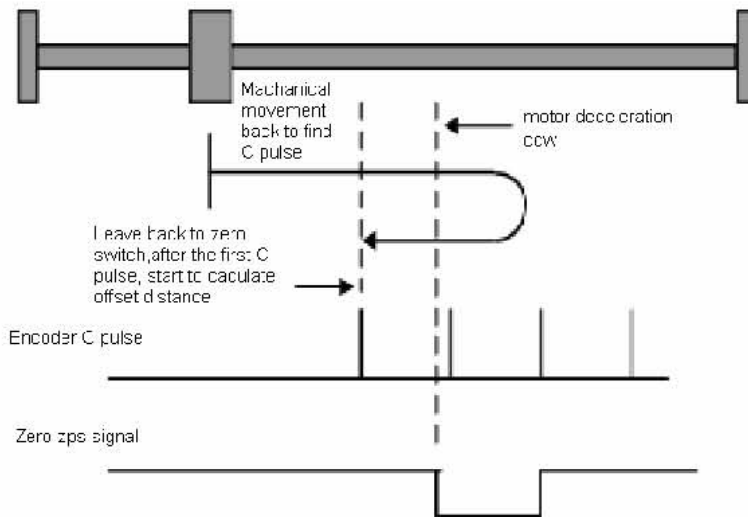

4.2.7 Parameter speed control

Being a simple way of speed control, user can preset the running speed as regulated value in "User Constant". When Servo is On, motor will run constantly at the preset speed. Speed change goes along with the value change in Pn048.

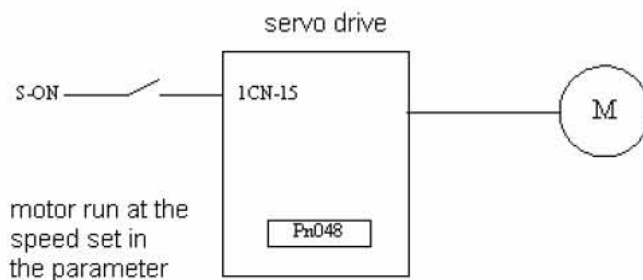

■ Set parameter speed

When using "parameter speed control", take following steps to make the setting.

1. Set Pn041 properly to enable internal speed selection function.

Parameter number	Name and meanings	Setting range	Factory setting	Application cases
Pn041	Control mode selection	0~2	0	Position control and speed control

In internal speed control mode, set Pn041 to 2.

Pn041 setting	Comments
2	Run at regulated speed of Pn048

Note:

1: OFF (input signal is inactive)

0: ON (input signal is active)

2. Set Pn048 to wanted speed value.

Value of Pn048 can be changed manually or via communication, to make motor run at specified speed. If the speed is set over maximum rotation speed, then motor will run at maximum speed instead.

3. Set "soft start time"

Parameter number	Name and meaning	Unit	Setting range	Factory setting
Pn019	Soft start acceleration time	ms	0~10000	100
Pn020	Soft start deceleration time	ms	0~10000	100
Pn021	S shape acceleration /deceleration time	ms	0~1000	0

- Servo drive sets internal acceleration and deceleration time and implements control of speed acceleration and deceleration according to these parameters
- Soft start function is available when control mode is internal speed control, parameter speed control and JOG running. In position control mode, soft start function is unavailable.

- When input speed reference is stair stepping, smooth speed control can be implemented by setting "Soft start time". Normally speed control is set to 0.

Meaning of parameter is described below:

- Pn019: the period of time from stop status to a speed of 1000r/min
- Pn020: the period of time from the speed of 1000r/min to stop status

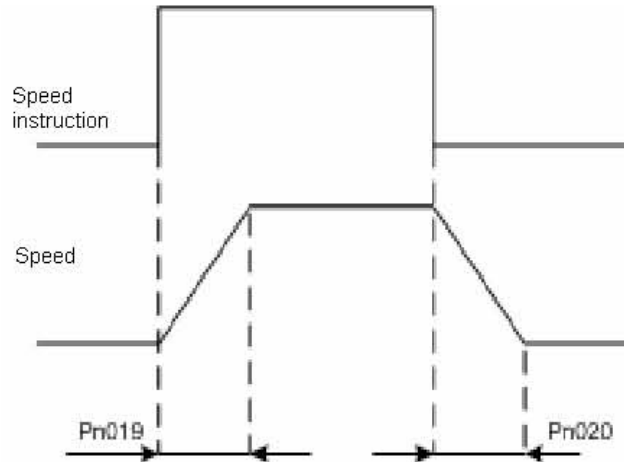

Pn019 and Pn020 are linear acceleration/deceleration time. In the event of rather large impact which may occur because linear acceleration/deceleration time are applied, Pn021 can be selected and set to get a smooth running.

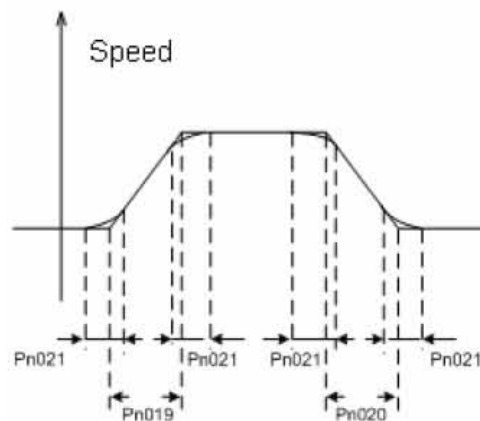

4. Torque limit

Setting Pn026 and Pn027 to limit torque is available in any control mode.

Parameter number	Function	Unit	Setting range	Factory setting
Pn026	forward run torque limit	1%	0~300	250

Pn027	reverse run torque limit	1%	0~300	250
--------------	--------------------------	----	-------	-----

Note:

1. System response may be slowed down if torque limit is set to an undersized value.

4.3 Servo drive settings

4.3.1 JOG speed

JOG speed control is enabled with PC communication or hand held operator. Set JOG speed with Pn032.

Parameter number	Name and meanings	Unit	setting range	Factory setting
Pn032	JOG speed	r/min	0~3000	500

Note:

1.No matter what value Pn041 is, or whether /S-ON is active or not, JOG running is always possible on the condition that cable connection of servomotor is correct and servo drive has no problem.

2.During JOG running, servo drive will ignore host controller's control signal and status of limit switch and property loss is easily caused due to improper operation. Therefore, JOG must be prohibited during normal production.

4.3.2 Control selection

Control modes can be selected with parameter Pn041 as described below.

Parameter No.	Control and description	Range	Factory setting
Pn041	[0]position control [1]internal speed control [2]reference speed control	0~2	0

- General information of above control methods are introduced as follows:

[0] position control (pulse train reference)

Servo drive accepts pulse train generated by host controller and speed and positioning are behaving according to host control's demand.

[1] position contact control (internal position reference)

Enable speed control by contact reference. Please refer to 4.2.7"internal speed control" of the manual.

[2] parameter speed control (parameter reference)

Run at constant speed as specified in Pn048.

The following table shows the meaning of some input signals in different modes.

Pn041	Control method	
0	<p>position control (pulse train reference)</p> <p>Normally, position control input reference refers to pulse train.</p>	<p style="text-align: center;">Servo drive</p> <div style="display: flex; align-items: center; justify-content: center;"> <div style="margin-right: 10px;"> <p>PULS</p> <hr style="width: 50px;"/> <p>Position instruction</p> </div> <div style="border: 1px solid black; padding: 5px;"> <p>1CN-11 1CN-12</p> <hr style="width: 50px;"/> <p>1CN-13 1CN-14</p> </div> </div>
1	<p>Internal position control (internal position reference)</p> <p>No external input signal is required. Run according to value in internal position register.</p>	
2	<p>parameter speed control (parameter reference)</p> <p>Servo motor rotates according to speed and status specified in Pn048 setting.</p>	

4.4 Stop function settings

4.4.1 Dynamic brake

Set the value of Pn004 to select stop mode of servo motor: DB braking or coast stop.

If dynamic brake is not used, motor stops naturally, with no brake, by using the friction resistance of the motor in operation.

Parameter number	Function	Parameter range	Factory setting
Pn004	Stop mode of servomotor when servo OFF or alarm occurs.	0~3	0

Parameter number	Comments
Pn004	[0] When servo OFF or alarm occurs, DB braking active [1] When servo OFF or alarm occurs, coasts to a stop. [2] When servo OFF or alarm occurs, DB braking active and is released after motor stops [3] When servo OFF or alarm occurs, coasts to a stop, DB active after motor stops

In following situation, servo drive will switch off power supply of servo motor.

- When /S-ON (1CN-15) signal is OFF
- When servo alarm occurs
- When power supply is OFF

Note:

Dynamic brake(DB) forces servomotor to stop immediately upon emergency, therefore, following notes must be considered.

(1) Do not start/stop servomotor frequently with power On/OFF switch, this will cause fast aging and reduced performance of the internal elements in the servo drive.

(2) Do not start/stop servomotor frequently with /S-ON(1CN-15), otherwise built-in energy consumption resistor is damaged easily .

“Dynamic brake (DB) ” is one way to force servomotor to stop immediately upon emergency.

By shorting power cable of servo motor to achieve emergency stop of servo

motor. This circuit is already built in EDC servo drive.

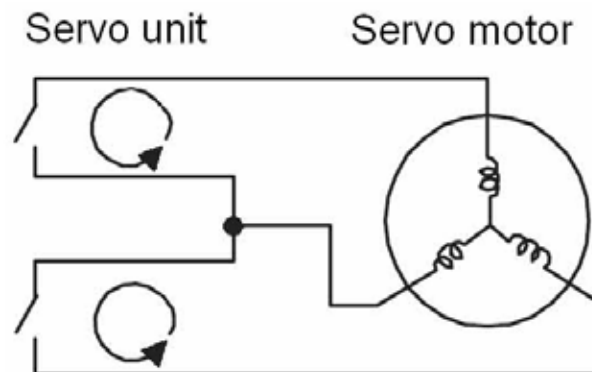

4.4.2 Holding brake

Servo motor with brake sticking(Holding brake) is required on the condition that perpendicular axis(the axis which withstands external force) is used, to prevent non-electrified servo motor from revolving around owing to action of the earth gravity.

The action of brake sticking is controlled by servomotor's brake interlock output signal (/BRK).

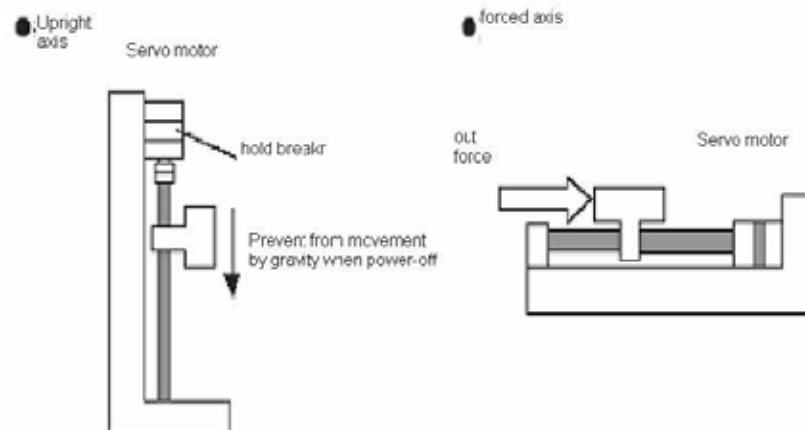

Make sure servomotor is mechanically separated before confirming action of servomotor and brake sticking(holding brake) . If all the parts are moving well, connect servo motor to the machine.

■ Connection example

/BRK controls Power On/Off of brake sticking, which consists of the control circuit of holding brake. The illustration below shows a typical connection example.

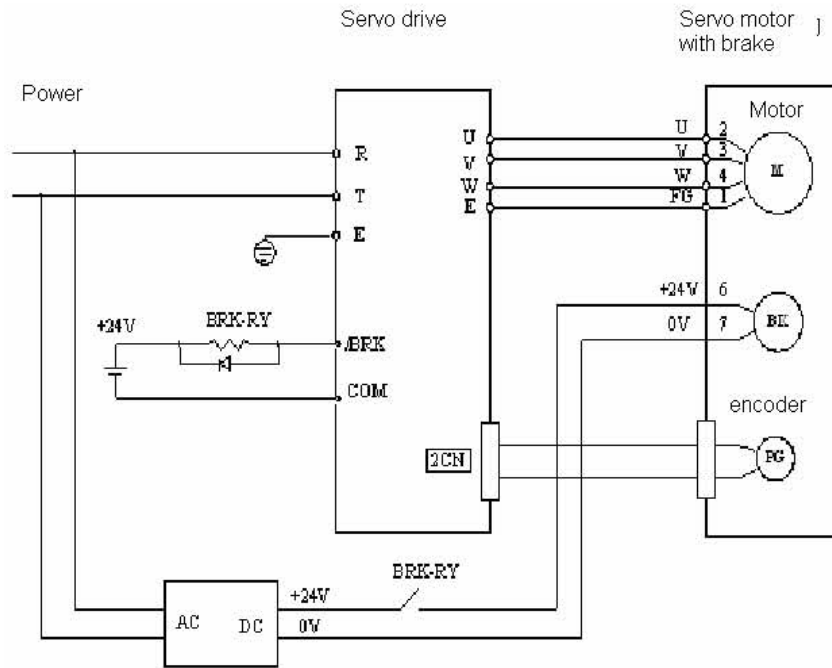

BRK-RY: brake sticking control relay

→ Output /BRK	Brake interlock output	Speed control, position control
---------------	------------------------	---------------------------------

/BRK is used to control the status of brake sticking. When brake sticking is not used, the connection is not required.

ON: "L" level	Release brake
OFF: "H" level	Start brake

Note:

If power beak occurs, servo drive will give no output of /BRK signal, and periphery circuit decides the status of brake sticking, which has to be considered when designing and control circuit.

When using /BRK signal, set output with following parameters.

Parameter number	Name and meanings	Setting range	Factory setting
Pn049	output signal1CN-2 pin definition	0~3	0
Pn050	output signal1CN-3 pin definition	0~3	1

Parameter	Name and meanings	Setting	Factory
-----------	-------------------	---------	---------

r number		range	setting
Pn055	Inverts output signal	0~7	0

Relevant parameters to Timing sequence are shown below.

Parameter number	Name and meanings	unit	Setting range	Factor y setting
Pn044	Basic waiting flow	ms	0~5000	10
Pn045	brake waiting speed	R/min	10~300	100
Pn046	brake waiting time	ms	10~1000	500

■ Brake ON/OFF time

During the moment of brake sticking on/off , if servomotor travels for tiny distance owing to external forces like earth gravity, adjust with Pn044 as below.

Parameter number	Name and meanings	Unit	setting range	Factor y setting
Pn044	Basic waiting flow (Servo OFF delay time)	ms	0~5000	10

The illustration below shows the timing sequence relation between signal /SON and BRK when motor stops (speed is lower than 30 r/m.)

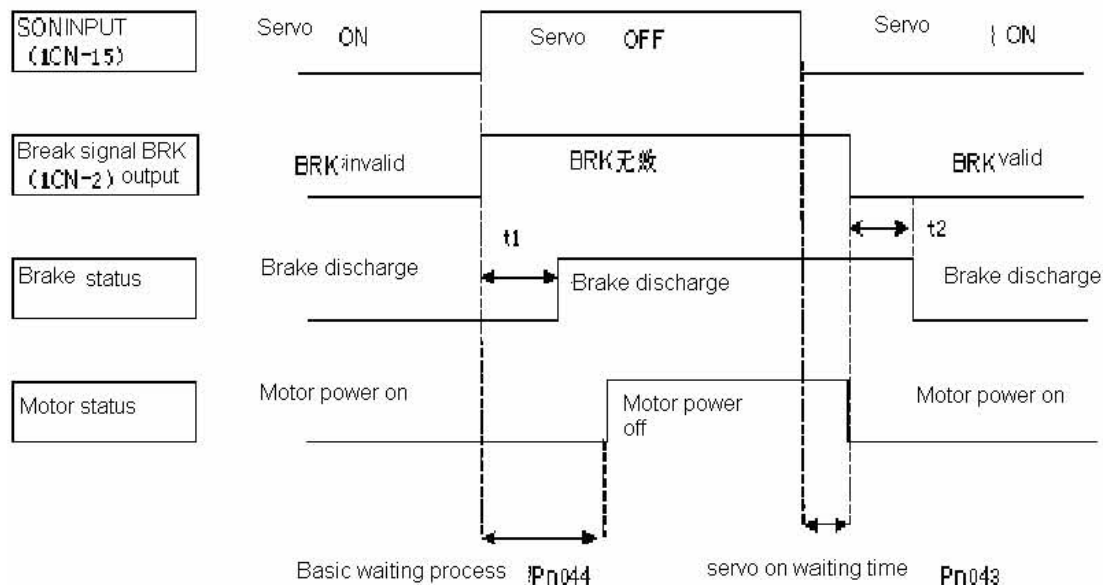

t1, t2: determined by external relay and brake loop move time

By factory setting, /S-OFF works with /BRK output at the same time. If load travels for tiny distance owing to action of earth gravity, Pn044 is required to be set so that action of /S-OFF is delayed, normally this unwished movement can

be removed.

Note:

When alarm occurs, servo drive will switch off main circuit loop of servo motor immediately, meanwhile, machine may move for tiny distance.

■ **Brake sticking setting**

During motor running, movement setting of brake sticking is controlled by Pn045 and Pn046. By controlling brake sticking's movement timing sequence , brake sticking is started correctly after servomotor stops running.

Parameter number	Name and meanings	Unit	setting range	Factor y setting
Pn045	Brake waiting speed	r/min	10~300	100
Pn046	Brake waiting time	ms	10~1000	500

The illustration below shows the timing sequence relation between signal /SON and BRK when motor stops (speed is higher than 30 r/m.)

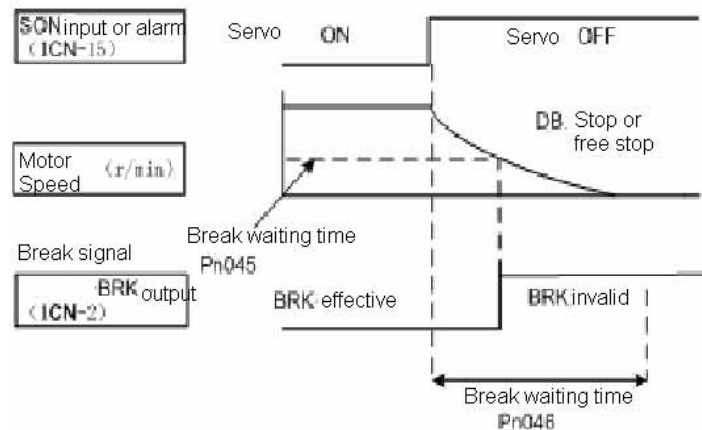

For a running brake sticking motor, if S-OFF is caused by variation of /S-ON or alarm occurrence , it's required to set brake waiting speed of servomotor or brake waiting time.

Brake waiting time(Pn046) refers to the period of time delay between motor stops(/S-OFF) and brake sticking takes action. This parameter should be adjusted while observing mechanical movements..

When servo motor is running, if any of following conditions is true, the output signal of /BRK will be ON.

- 1: After servo OFF, motor speed is lower than setting value of Pn045.
- 2: After servo OFF, motor speed is higher than setting value of Pn046.

4.5 Protection sequence design

4.5.1 Servo alarm output

The following diagram shows the right way to connect Alarm Output.

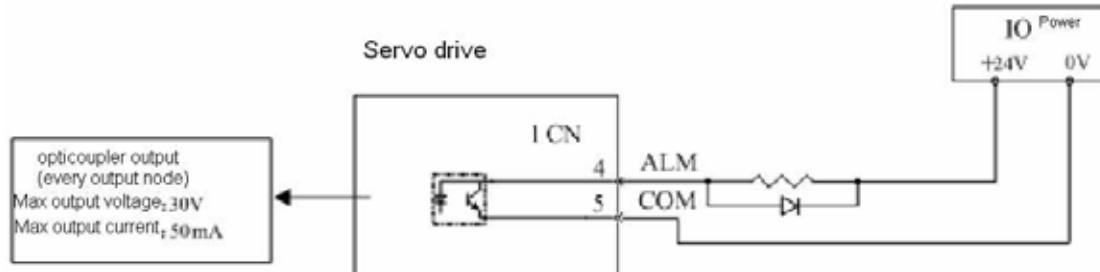

External +24V I/O power supply is required, since there is no +24V power supply available inside servo drive.

Output → ALM	1CN- 4	Servo alarm output
COM	1CN- 5	Servo alarm output uses grounding signal

Normally, the external circuit consists of /ALM should be able to switch off power of servo drive.

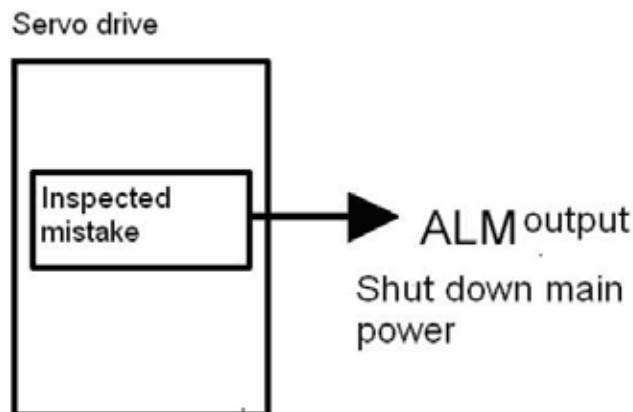

Signal	Status	Output level	Comments
ALM	ON	1CN-4: "L" level	Normal state (output signal is high when alarm occurs)
	OFF	1CN-4: "H" level	Alarm state (output signal is high when alarm occurs)

When "servo alarm(ALM)" happens, always remove alarm reasons first, and then turn the input signal "ALM-RST" to ON position to reset alarm status.

→ input 6	ALM-RST 1CN-	alarm reset input
--------------	--------------	-------------------

Signal	Status	Input level	Comments
ALM-RS	ON	1CN-6: "L" level	Reset servo alarm
T	OFF	1CN-6: "H" level	Does not reset servo alarm

Normally, the external circuit can switch off power supply of servo drive when alarm occurs. When servo drive is re-switched on, it removes alarm automatically, so normally alarm reset signal is not required to be connected.

In addition, reading alarm information and alarm reset are enabled with hand-held operator.

Note:

When alarm occurs, always remove alarm reasons before resetting alarms.

Note:

Only alarms with alarm number being 3,4,13,14,15 and 21 can be removed by /ALM-RST.

4.5.2 /S-ON input

Host controller is used to control enable or disable servo system.

Following illustration shows the way to connect /S-ON.

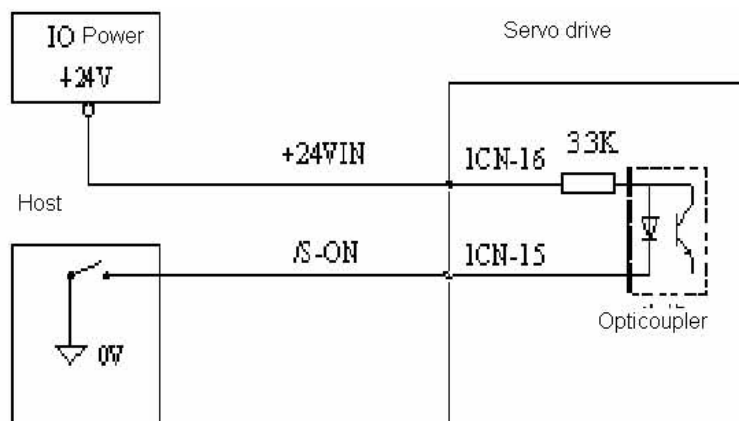

→ input 15	/S-ON 1CN-	Servo On (ON)
---------------	------------	---------------

Switch servomotor between Power on and Power off. When low level is active.

Signal	Status	input level	Comments
/S-ON	ON	1CN-15: "L" level	Servo ON, servo is energized(run servomotor according to input signal)
	OFF	1CN-15: "H" level	Servo OFF, servo is not energized(can't run)

Pn043 is used to set waiting time during Servo On, which means the period of time from internal relay's action to motor electrification.

Parameter number	Name and meanings	Unit	Setting range	Factory setting
Pn043	Waiting time when servo On	ms	20~2000	100

Note:

1. It's not good to start/stop servomotor frequently with "/S-ON" signal. Always use input reference to complete response operation, otherwise servo motor's lifetime will be shortened.
2. When "/S-ON" high is active, if external cable is disconnected, input signal is high, /S-ON will keep active.
3. During deceleration of Servo OFF, /S-ON signal is accepted only when motor speed is lower than 30r/m.

Switch "Enable/Disable" Servo On input signal with the following parameter.

Parameter number	Name and meanings	Unit	Setting range	Factory setting
Pn000	[0] Enable Servo ON input signal (/S-ON) (Decided by 1CN-15 signal) [1] Disable Servo ON input signal (/S-ON) (internal Servo ON, normally is Servo ON, which is equivalent to 1CN-15 being active.)	—	0~1	0

4.5.3 Positioning complete output

Positioning complete"/COIN" signal: output after positioning completes.
Make connection according to the following diagram.

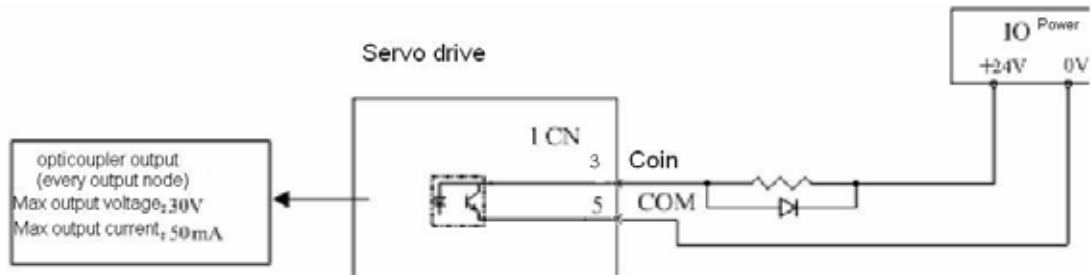

Output → /COIN	Positioning complete Output	position control
Output → COM	Positioning complete Output grounding signal	position control

Host controller can judge if servo action is completed or not with /COIN.

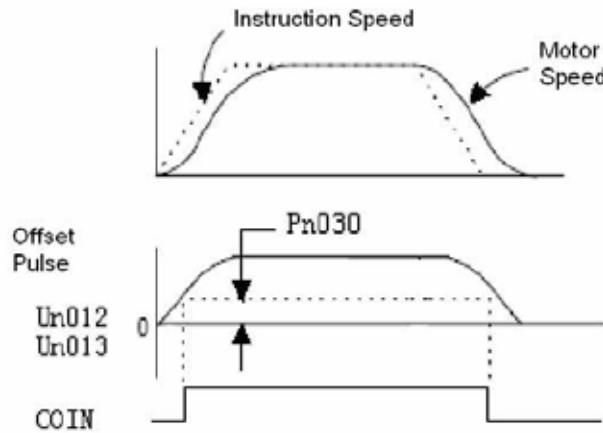

Un012: error pulse counter low position monitoring

Un013: error pulse counter high position monitoring

When output is active at low level:

ON status level	COIN: "L"	Positioning has completed. (Position offset is lower than setting of Pn030.)
OFF status level	COIN: "H"	Positioning is not completed. (Position offset is lower than setting of Pn030.)

Set "In position error" to control output time of /COIN.

Parameter number	Function	Unit	setting range	Factory setting	Using method
Pn030	In position error	reference unit	0~500	10	position control

Setting of In position error will not affect final accuracy of positioning.

By default, 1CN-3 is used as Positioning complete signal "/COIN" in position control mode, while in speed control mode it's used as the speed coincidence output "V-CMP".

4.5.4 Speed coincidence output

Speed coincidence Output (/V-CMP) signal: photocoupler output signal, referring to output is given when rotation speed of servo motor is the same as reference speed. It can be used as the base of host controller's judgement. Connect and use this signal according to the following diagram:

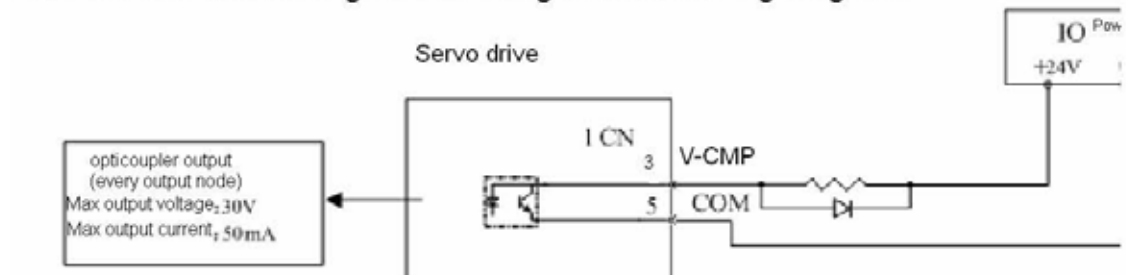

Output → /V-CMP+	speed output	coincidence	Speed control
COM	speed output signal	coincidence grounding	Speed control

It refers to output signal of input speed reference and speed coincidence of actual motor rotation. When output status at low is active:

ON status level	/V-CMP+ "L"	Speed coincidence (speed error is under setting value)
OFF status level	/V-CMP+ "H"	Speed coincidence fail (speed error is over setting value)

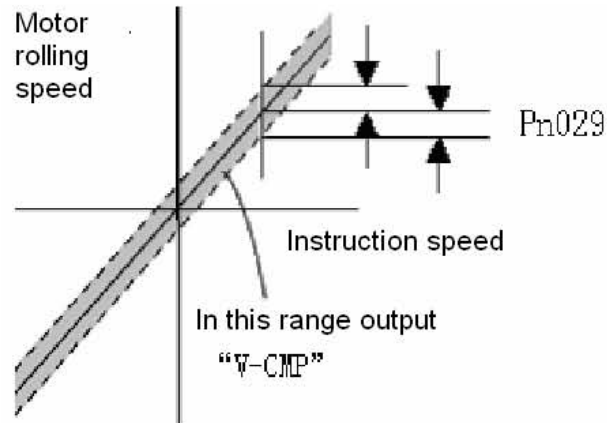

With the user's constant as below, the range of output /V-CMP can be designated.

Parameter number	Function	Unit	setting range	Factory setting	Using method
Pn029	Speed coincidence error	r/min	0~100	10	Speed control

When difference between speed reference and actual motor speed is under setting value, output "/V-CMP" signal.

4.5.5 Handling instant power cut

Select if alarm output is made or not upon a sudden power interruption.

Parameter number	Name and meanings	Unit	setting range	Factor y setting
Pn003	Select operations to be made upon power interruption [0] gives no output of servo alarm signal (ALM) [1] Output servo alarm signal (ALM)	—	0~1	0

If power supply of servo drive is interrupted suddenly over 20ms and detected by servo drive. Servo drive will decide if /S-ON and output servo alarm are required according to the value of Pn003

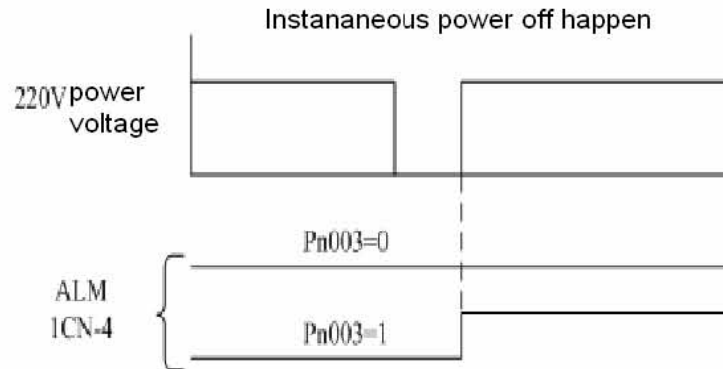

Normally, set Pn003 to zero(0).

4.5.6 Regenerative braking unit

When servo motor runs in dynamo mode, electric power feedback goes to servo drive side, this kind of power is normally called regenerative electric power.

Regenerative electric power is absorbed by means of charging the smoothing capacitor inside servo drive with its power. If the power exceeds the capacity of the smoothing capacitor, additional "Regenerative braking unit" is required to transform regenerative electric power into heat energy consumption of a bleeder or drain resistor, otherwise servo drive may output overvoltage alarm.

Servo motor runs in dynamo mode subject to following conditions.

- during deceleration to stop
- inertia load on perpendicular axis
- servo motor runs continuously due to load side (negative load)

Note:

1. EDC servo drive does not provide a built-in regenerative resistor, so external regenerative unit must be equipped if required.
2. Terminal P and Terminal N from servo drive are leading to drive's main circuit power(high voltage on DC generatrix), therefore, it's prohibited to be connected directly to bleeder or drain resistor.

■ **Connect external regenerative unit according to following diagram.**

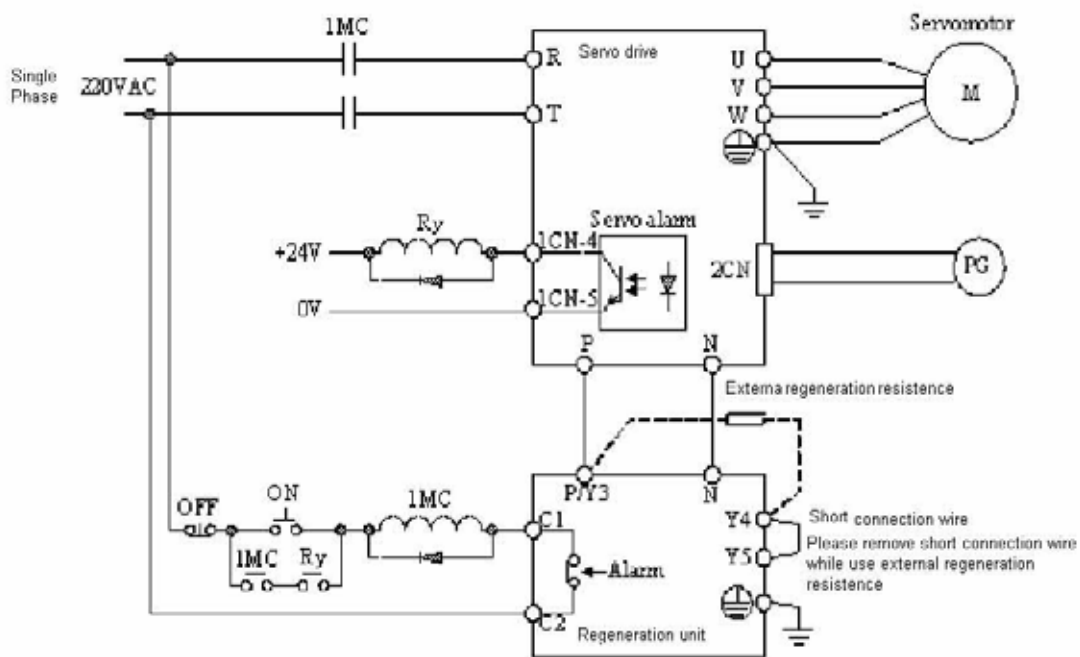
**Note:**

Before connection and installation, please refer carefully to all the precautions in the instruction of the regenerative unit which is to be used.

4.6 Smooth running

4.6.1 Smoothing

Servo drive can perform smoothing filtering on "reference pulse" input of certain frequency.

Parameter number	name	unit	Setting range	Factory setting
Pn024	position reference 1st filter	Ms	0~1000	0
Pn025	Feed forward filtering	Ms	0~1000	0

By adjusting the parameters, the smoothing performance of position control can be changed.

4.6.2 Acceleration/deceleration time

Servo drive can perform acceleration and deceleration on speed reference to have soft start function.

Parameter number	Name	Unit	Setting range	Factory setting
Pn019	Soft start acceleration time	ms	0~10000	100
Pn020	Soft start deceleration time	ms	0~10000	100
Pn021	S-shape acceleration and deceleration time	ms	0~1000	0

- Pn019: time from stop status to speed of 1000r/min
- Pn020: time from speed of 1000r/min to stop status

Pn019 and Pn020 are linear acceleration / deceleration time. When large impact happens because linear acceleration / deceleration is used to start/stop the machine, Pn021 can be set to have smooth running.

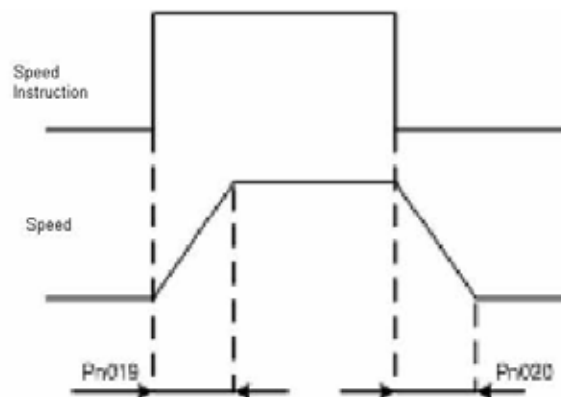

Inside servo drive, perform acceleration and deceleration of the set value on speed reference to implement speed control.

When inputting steplike speed reference, smooth speed control can be implemented.

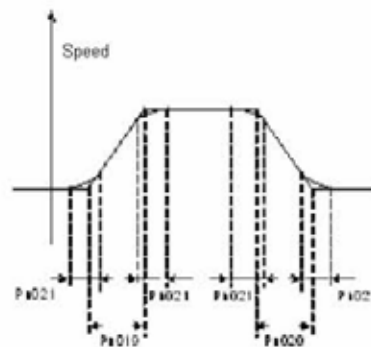

4.6.3 Speed detection smoothing time constant

By adjusting "speed checkout filter time constant", mechanical vibration caused by servo system can be removed or eliminated.

Parameter	Name	unit	setting range	Factory setting
Pn028	Speed checkout filter time constant	1%	0~500	0

The smaller the value of constant is, the better control response is shown. Actual situation will be restrained by mechanical structure. If mechanical vibration occurs when default setting is used, adjust this parameter to a larger value, normally the vibration can be restricted effectively.

4.6.4 Torque reference filter time constant

When mechanical vibration is caused by servo drive, "Torque reference filter time constant" can be adjusted to remove or eliminate vibration.

Parameter	Name	unit	setting range	Factory setting
Pn018	Torque reference filter time constant	1%	0~5000	0

The smaller the value of constant is, the better control response is shown. Actual situation will be restrained by mechanical conditions.

If mechanical vibration caused by servo occurs when standard setting is used, adjust this parameter to a larger value, the vibration can also be restricted effectively. The reason of vibration may be by incorrect gain adjustment or machine problems.

4.7 High speed positioning

4.7.1 Servo gain settings

■ Setting speed loop gain

Parameter	name	Unit	Setting range	Factory setting
Pn007	Select speed loop control method		0~1	0

0: ADRC control

1: PI control

Please be noticed when this parameter is changed, corresponding Pn013 and Pn014 will change, too. Generally, when Pn007 = 1, value of Pn013 and Pn014 need to be reduced.

■ Speed feed forward

Parameter	name	Unit	Setting range	Factory setting
Pn012	Speed feed forward		0~1	0

0: disable speed feed forward

1: enable speed feed forward

Inertia inspection is required before using this function. With this function, speed response is enhanced and setting time is reduced.

■ Setting speed loop gain

Parameter	name	Unit	Setting range	Factory setting
Pn013	Speed loop gain (Kv)	Hz	1~3000	160
Pn014	Speed loop integral time constant (T i)	ms	1~2000	250

The above information shows internal speed loop gain and integral time constant of servo drive.

The larger the speed loop gain is set or the smaller the speed loop integral time constant is set, the easier to have fast response speed control and this is limited by mechanical features. The larger the speed loop integral time constant is set, servo has better steady-state performance. But too large value may cause system vibration easily.

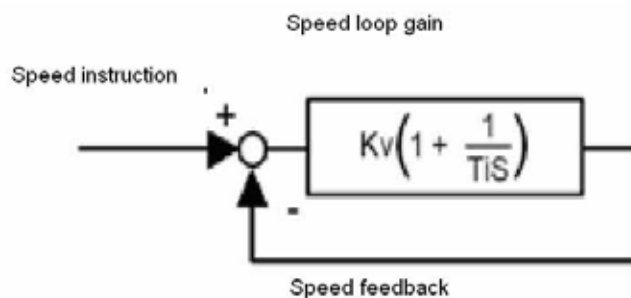

■ Setting position loop gain

Parameter	name	Unit	Setting range	Factory setting
Pn015	Position loop gain (Kp)	1/s	1~1000	40

The larger the position loop gain is set, the easier to have position control with high response and small offset and this is limited by mechanical features. Owing to affection of load, vibration and overshoot may occur easily if the gain is set too large.

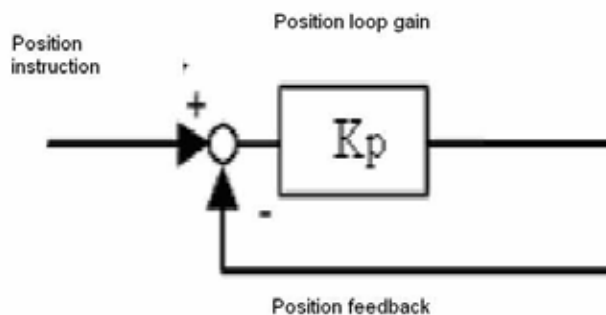

Parameter	name	Unit	Setting range	Factory setting
Pn031	overflow range of error counter	256 reference unit	1~32767	1024

This parameter is used to check offset pulse number of overflow alarm (AlarmA.06) .

Parameter	Name	Unit	Setting range	Factory setting
Pn047	Enable/Disable alarm when position error pulse overflows [0] no alarm output [1] output alarm		0~1	0

This parameter is used to decide whether offset overflow alarm (alarmA.06) is required or not.

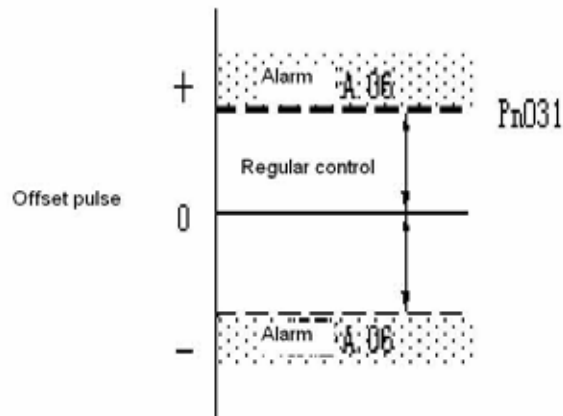

When Pn047 is set to 1, if the range of error counter overflow(Pn031) is set too small, alarm A.06 may occur when running at high speed.

■ Position feedforward

With feed forward control, positioning time is reduced.

Parameter	Name	Unit	Setting range	Factory setting
Pn017	Position feed forward gain	%	0~100	0

Inside servo unit, feed forward compensation is used for positioning control to reduce positioning time. But if the gain is set too large, overshoot and machine vibration may occur. As for normal machines, please set the gain to 80% or lower.

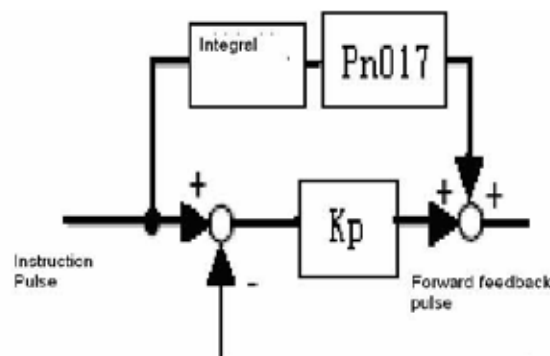

4.7.2 Speed offset settings

By setting internal speed reference offset of servo unit, adjusting time for positioning control can be reduced.

Parameter	Name	Unit	Setting range	Factory setting
Pn016	Speed offset	r/min	0~300	0

Inside servo unit, the specified speed reference offset for positioning control, are used to reduce positioning time. Make the setting according to mechanical conditions.

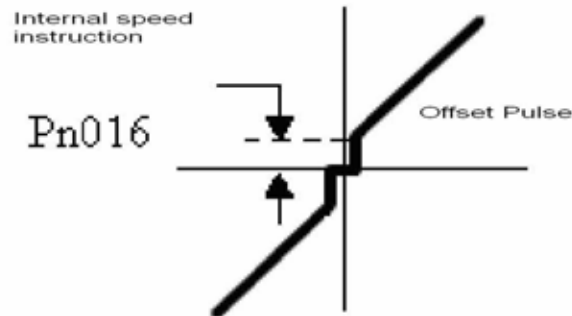

Note:

When positioning error is set low, while speed offset is set a bit large, overshoot or vibration may occur during system running. Please pay close attention when using this parameter.

Chapter 5 Troubleshooting

5.1 Alarm list

Servo drive will output an alarm when abnormal event is detected.

The LED for POWER&ALM on the front panel of the servo drive will turn red when alarm occurs(The LED is green in normal status), meanwhile, the drive outputs an alarm. If an external hand-held operator is installed, current alarm code can be displayed on the operator.

Alarm display on digital operator	Alarm output	Alarm Name	Meaning
A. 01	×	Parameter breakdown	Checksum results of parameters are abnormal.
A. 02	×	Current detection error	Internal detection circuit problem
A. 03 *	×	Overspeed	Rotation speed of the motor has exceeded 1.1 times of maximum speed
A. 04 *	×	Overload	The motor was running for several seconds to several tens of seconds under a torque largely exceeding ratings.
A. 05	×	Position error counter overflows	Internal position error counter has exceeded the value
A. 06	×	Position error pulse overflows	Position error pulse has exceeded the value set in parameter Pn-031.
A. 09	×	Pulse loss of Encoder C	PC is disconnected or have interference
A. 10	×	Encoder disconnected	At least one of PA, PB, PC, PU, PV or PW is disconnected
A. 11	×	Encoder UVW code violation	Encoder UVW code violation
A. 12	×	Power module error	Power module failure
A. 13 *	×	overheat	Power module overheat
A. 14 *	×	Voltage error	Overvoltage or undervoltage of main circuit
A. 15 *	×	Frequency error of input pulse	Pulse frequency input is too high, has exceeded the allowance
A. 16	×	Parameter error	Parameter saved in external storage has errors
A. 17	×	I/O data error	I/O data error, such as ALM, BRK, COIN, Relay, LED lamps, etc. errors

A. 21 *	×	Power loss error	A power interruption exceeding one cycle occurred in AC power supply
A. 25	×	Watchdog reset	System reset by watchdog
A. 99	○	Not an error	Normal operation status

- :Photo-coupler is ON(ON)
 ×:Photo-coupler is OFF (OFF)
 * :Alarm can be cleared

Clear alarms in following ways when alarm occurs:

- Set 1CN-6 signal active(alarm reset signal ALM_RST)
- Clear alarm with hand-held operator (please see 6.1.2 for reference)
- Through matched PC communication software
- Turn power OFF and then ON again.

Notes:

1. When alarm occurs, always find out the alarm reasons and remove alarm failures before clearing alarm.
2. Only the alarm codes listed below can be cleared: A.03, A.04, A.13, A.14, A.15, A.21.

5.2 Alarm reasons and Troubleshootings

Find out the alarm reasons with help of the alarm codes displayed on the hand-held operator or view via the communication software in a PC.

Only the last 8 alarm records are saved in the servo drive, which can be viewed via the operator or PC communication software.

The alarms without the sign of * are not able to be removed. To clear the alarms, user has to turn power OFF and ON again.

No.	Name	Status	Possible reasons	Treatments
01	Para. breakdown	During system acceleration or deceleration; During system running	Checksum results of parameters saved in external storage are abnormal.	<ul style="list-style-type: none"> ➢ Power On again and check if the same problem still exists. ➢ If problem still exists, the chip needs to be replaced because external storage of the drive has been damaged.
02	Current detection error	System is Power ON	Sampling circuit damaged	<ul style="list-style-type: none"> ➢ Check reference power supply of A/D circuit on the servo drive, to see if the reference supply has been damaged; ➢ Check if the mainboard and control plate are reliably connected.

03 *	Overspeed	During system running	<p>Motor speed has exceeded 1.1 times of maximum speed.</p> <ul style="list-style-type: none"> ➢ reference pulse input too high; ➢ Acceleration /Deceleration time constant too short, which cause speed overshoot; ➢ Electric gear ratio is too big ➢ P-Gain value(Pn015) is too small 	<p>When motor overspeed happens, please take following actions:</p> <ul style="list-style-type: none"> ➢ Reduce set speed(reference value) ➢ Increase appropriately the value of smoothing time constant (Pn024) ➢ Increase appropriately the value of position proportional gain (Pn015) ➢ Check gear ratio, the ratio should be set within the range as below: input pulse frequency × Electric gear 500 KHZ
04 *	overload	During system acceleration or deceleration; During system running	<p>System run over rated torque for seconds and tens of seconds:</p> <ul style="list-style-type: none"> ➢ Acceleration /Deceleration time constant too short ➢ capacity of drive and motor not enough ➢ Load is too big ➢ start stop frequency is too high 	<ul style="list-style-type: none"> ➢ Ncrease Acceleration /Deceleration time; ➢ Use drive and motor of larger power instead ➢ Check load ➢ Reduce start stop frequency
05	Position error counter overflow	During system running	<p>Absolute value of position error counter has exceeded 2^{19}.</p> <ul style="list-style-type: none"> ➢ Motor is stuck mechanically ➢ Input reference pulse is abnormal 	<ul style="list-style-type: none"> ➢ Check and see if motor rotates according to reference pulse ➢ Check mechanical parts of load ➢ Check reference pulse ➢ Check motor encoder cables

No.	Name	Status	Possible reasons	Treatments
06	Position error pulse overflows	During system running	<p>Position error pulses has exceeded limit value of position error counter overflow(Pn031)</p> <ul style="list-style-type: none"> ➢ Motor is mechanically stuck ➢ Input reference pulse is abnormal 	<ul style="list-style-type: none"> ➢ Check motor encoder cables ➢ Check mechanical parts of load ➢ Readjust increment, increase P-Gain value(Pn015) ➢ Increase value of Pn031(position error counter overflow) ➢ Increase value of position feed forward(Pn017) ➢ Reduce load value and speed
09	Pulse loss of Encoder C	During system running	<p>Motor runs for several cycles, no C pulse signal appears.</p> <ul style="list-style-type: none"> ➢ Cable problems: improper cable connection or cable disconnected ➢ Cable not well shielded ➢ Encoder damaged ➢ Shielded grounding wires are not connected well ➢ Circuit failure of encoder interface 	<ul style="list-style-type: none"> ➢ Check cable connection, do not bind encoder signal cables together with motor input power wires. ➢ Check interface circuit of encoder
10	Encoder disconnected	During system power on or system running	<p>At least one of PA, PB, PC, PU, PV or PW is disconnected</p>	<ul style="list-style-type: none"> ➢ Check connection cables of motor encoder ➢ Check encoder signals ➢ If the above items are OK, there might be some problem in th internal parts of servo drive

11	Encoder UVW code violation	During system power on or system running	Encoder UVW code violation is detected (UVW signals are all high level or all low level). Please be noted the UVW signal of encoder is different from UVW of power signal. <ul style="list-style-type: none"> ➢ Incorrect encoder cable connection ➢ Encoder damaged 	Please make sure power supply of encoder is 5V +/-5%. This has to be met especially when the cables are very long. Don't bind encoder input cables together with motor input power wires, and shield wired have to be connected to the frame. <ul style="list-style-type: none"> ➢ Correct encoder cable connection according to connection diagram ➢ Replace servo motor
12	Power module error	During system power on or system running	Too high current flow through the power module or VCC4 control voltage is a little lower.	<ul style="list-style-type: none"> ➢ Take away the motor power wire signal(U, V, W), power ON, Servo is disabled, is this problem still happens, it's most likely the power module has been damaged ➢ Check connection of U, V and W ➢ Check isolation resistance between (U,V,W)and grounding wires, if the resistance is a bit lower, that means motor isolation is worse, motor needs to be replaced. ➢ Check if the capacity between motor and drive is matched or not ➢ Check to see if the control power VCC4 of the power module is OK or not(Alarm occurs when it's a little lower) ➢ Increase acceleration /deceleration time ➢ Check to see is DB relay is damaged or not

No.	Name	Status	Possible reasons	Treatments
13 *	Overheat	During system running	Power module overheat <ul style="list-style-type: none"> ➢ Drive is running at heavy load for a long time, which causes module overheat ➢ Frequent start stop ➢ Ambient temperature is too high, or air ventilation is bad 	<ul style="list-style-type: none"> ➢ Replace the drive ➢ Change environment condition, improve air ventilation or convection
14 *	Voltage error	During Power ON or during system running	Overvoltage or undervoltage of main circuit	<ul style="list-style-type: none"> ➢ Measure voltage at input terminal(between R and T) to see if the input voltage is within required range ➢ Increase Acceleration /Deceleration time ➢ Lower down start stop frequency
15 *	Frequency error of input pulse	During system running	Pulse frequency input is too high, has exceeded the allowance	<ul style="list-style-type: none"> ➢ Please set an appropriate reference frequency ➢ Take actions to remove the noise ➢ Adjust value of Pn022 and Pn023, decrease the multiplication factor tc ensure reference pulse frequency is less than 500Kpps. (Reference pulse frequency = input reference frequency × dividing multiplication frequency)

16	Parameter error	During system running	Parameter saved in external storage has errors	<ul style="list-style-type: none"> ➢ Check if parameter settings are correct or not ➢ Load in default parameters, check is the data is correct or not ➢ Replace U3 chip
17	Encoder error	During system Power ON	wire saving encoder is ignored, encoder is not connected, or confused by general incremental encoder with wire saving encoder	<ul style="list-style-type: none"> ➢ incorrect motor model ➢ Pn225 setting error
21 *	Instantaneous power loss error	During system running	A power interruption exceeding 20ms occurred in AC power supply.	<ul style="list-style-type: none"> ➢ Check if input voltage of drive is normal
25	Watchdog reset	During system running	System reset by watchdog	<ul style="list-style-type: none"> ➢ Current detection error ➢ External serial COM is abnormal

5.3 Clear alarm

■ Clear current alarm

When an alarm occurs, press ENTER for seconds in hand-held panel operator's status display mode, then current alarm is deleted. Besides, the alarm can also be cleared by using 1CN-6(ALM_RST) input signal.

Notes:

1. Only current alarms with "*" sign in 5.2 can be deleted.
 2. Eliminate alarm cause first, then input 1CN-6 (ALM_RST) signal, current alarm is removed immediately.
 3. During effective period of 1CN-6 (ALM_RST) signal, motor is in free status, that equals to SERVO OFF status.
-

■ Clear alarm history

In the auxiliary function mode of panel operator, with Fn000, the latest eight (8) alarms can be deleted. Refer to instructions in 6.2.1.

Chapter 6 Panel Operator

6.1 Basic Function

6.1.1 Function description

An external panel operator as shown below can be connected to EDC series of servo drives to make parameter setup, status monitoring and auxiliary functions.



The description of the keys on the panel operator and their functions are followed by a panel operator on initial display status as an example.

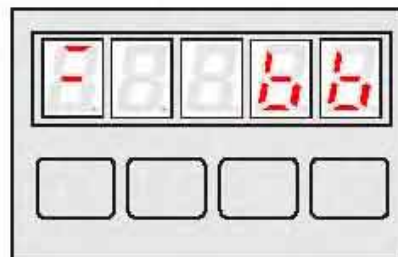

Name	Function
INC key	Press INC key to increase the set value(a long and hold on press will implement fast increasing)
DEC key	Press DEC key to decrease the set value.(a long and hold on press will implement fast decreasing)
MODE key	Press this key to select the status display mode, parameter setup mode, monitor mode, or auxiliary function mode. Press this key to cancel setting when setting the parameters.
ENTER key	Press this key to display the parameter settings and set values.

6.1.2 Reset Servo Alarms

In alarm status display mode of the operator, press ENTER key and hold on for seconds to reset current alarm.

Refer to 5.1 and clear alarm code.

The alarm can also be removed by using 1CN-6(/ALM_RST) input signal.

If the power supply is switched OFF due to a servo alarm, then alarm reset operation is not necessary.

Note:

When any alarm occurs, always remove alarm reasons first before performing alarm reset.

6.1.3 Display mode selection

By toggling among the different basic modes on the panel operator, operations like current running status display and parameter setup can be performed.

The operator consists of following basic modes:

Status display, Parameter setup, Monitor mode and Auxiliary function mode.

Press MODE key to select a display mode in the following order.

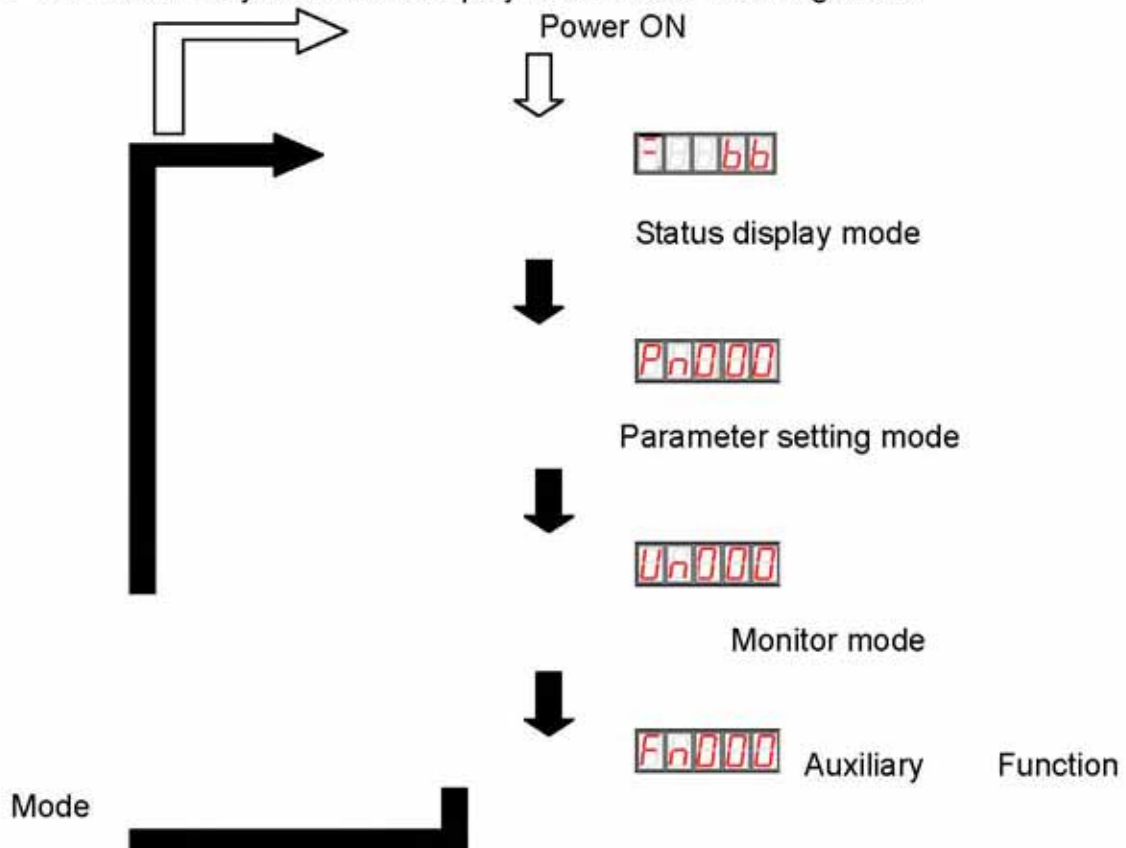

6.1.4 Status Display Mode

In status display mode, the digits and simple code are used to show the status of servo drive.

■ Selection of Status Display Mode

The status display mode is displayed when the power is turned ON.

If current mode is not the status display mode, press MODE key to switch to required mode.

■ Contents displayed in Status Display Mode

Contents displayed in the mode are different in Position Control Mode and Speed Control Mode.

When in Speed Control mode

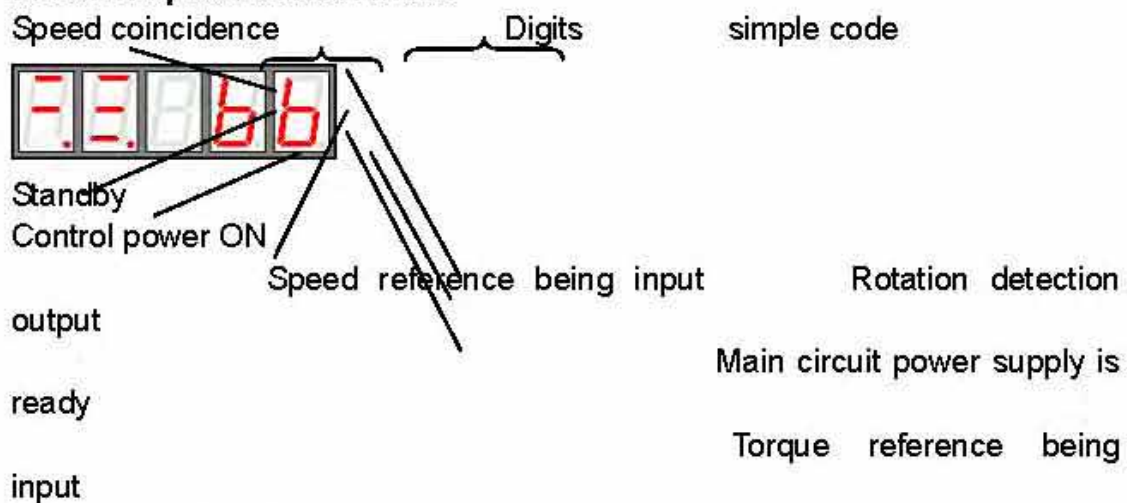

Digit data	Description
Control power is ON	Lamp lights on when control power of servo drive is ON
Standby	Lamp lights on when servo is on standby; Lamp extinguishes when servo is ON
Speed coincidence	When offset value between speed reference and actual motor speed is within allowable value, lamp lights on. Allowable value: Pn029 (The standard value is 10 min/r)
Rotation detection output	When motor speed exceeds allowable value, lamp is lit. When motor speed is lower than allowable value, lamp goes extinct. Allowable value: 10% of rated speed
Reference speed input is continuing	When reference speed input exceeds allowable value, lamp is lit. When reference speed input is lower than allowable

	value, lamp goes extinct. Allowable value: 10% of rated speed
Reference torque input is continuing	When reference torque input exceeds allowable value, lamp is lit When reference torque input is lower than allowable value, lamp is extinct. Allowable value: 10% of rated torque
Main circuit power supply is ready	Lamp is lit when main circuit power supply is OK; Lamp is extinct when main circuit power supply is OFF.

Contents of simple code display

Code	Meaning
	On standby; Servo OFF (Servomotor power is OFF)
	Run Servo ON (motor power is ON)
	Alarm Blinks the alarm number.

When in Position Control mode

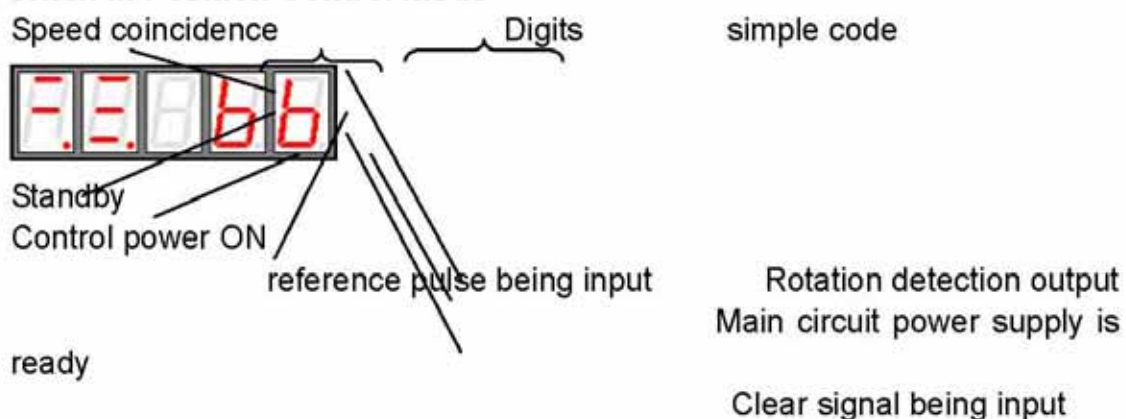



Contents of digit display

Digit data	Description
Control power is ON	Lamp lights on when control power of servo drive is ON
Standby	Lamp lights on when servo is on standby; Lamp extinguishes when servo is ON
Speed coincidence	When offset value between position reference and actual motor position is within allowable value, lamp lights on. Allowable value: Pn030 (The standard value is 10

	pulse)
Rotation detection output	When motor speed exceeds allowable value, lamp is lit. When motor speed is lower than allowable value, lamp goes extinct. Allowable value: 10% of rated speed
Reference pulse input is continuing	When reference pulse input is continuing, lamp is lit. When there is no reference pulse input, lamp goes extinct.
Clear signal input is continuing	When clear signal input is continuing, lamp is lit. When there is no clear signal input, lamp goes extinct.
Main circuit power supply is ready	Lamp is lit when main circuit power supply is OK; Lamp is extinct when main circuit power supply is OFF.

Contents of simple code display:

Code	Meaning
	On standby; Servo OFF (motor power is OFF)
	Running; Servo ON (motor power is ON)
	Alarm Status The alarm code is displayed.

6.1.5 Parameter Setting Mode

Parameters related to the operation and adjustment of the servomotor are set in this mode.

See the Parameter List in Appendix A for details.

■ Change parameters

Please see the Parameter List in Appendix A to know exactly the range of parameter change.

Following is an operational example of changing the data of Pn 019 from 100 to 85.

1. Press MODE key to select parameter setup mode.



2. Press INC key or DEC key to select parameter number.



3. Press ENTER key to display parameter data selected in step 2.



4. Press INC or DEC to change the data to the desired number 85. Hold the button to accelerate the value changing.

When the data reaches the max. or Min. value, the value will stay unchanged even if INC/DEC key is pressed.



5. Press ENTER, the data glimmers and then the date is saved.



6. Press ENTER again to go back to parameter number display.



Plus, if Mode key is pressed during step 3 or step 4, parameter setup operation will go directly to step 6 and no changes will be saved. If the user needs to rechange any data later, just repeats the operation from step 2 to step 6.

If Pn080 needs to be set as -32767, then a decimal point is used on bottom right corner of the top number to show current value is negative. For instance, the value - 32767 is displayed as below:



6.1.6 Monitor Mode

The monitor mode can be used for monitoring the external reference values, I/O signal status and internal status of servo drive. User can make changes in Monitor Mode even if motor is running.

■ Following are the operation steps to use Monitor Mode

The example as below shows the operation steps for monitoring Data 1500 of Un001.

1. Press MODE key to select monitor mode.



2. Press INC key or DEC key to select the monitor number to be displayed.



3. Press ENTER to display the monitored data selected in Step 2.



4. Press ENTER again to return to monitor number display.



■ Contents of Monitor Mode display

Monitor No.	Contents	
Un000	Actual motor speed: r/min	
Un001	Input speed reference value: r/min	
Un002	Percentage of feedback torque: % (relative rated torque)	
Un003	Percentage of input torque: % (relative rated torque)	<p>Digits to display internal status</p> <p>9 8 7 6 5 4 3 2 1 0</p>
Un004	Number of pulses of Encoder angles	
Un005	I/O signal monitor	
Un006	Encoder signal monitor	
Un007	Speed given by pulse (when electronic gear ratio is 1:1)	
Un008	Current motor position is 5 digits lower ($\times 1$ pulse)	
Un009	Current motor position is 5 digits higher ($\times 10000$ pulse)	
Un010	Position reference is 5 digits lower ($\times 1$ pulse)	
Un011	Position reference is 5 digits higher ($\times 10000$ pulse)	
Un012	Position offset is 5 digits lower ($\times 1$ pulse)	
Un013	Position offset is 5 digits higher ($\times 10000$ pulse)	

Notes:

1. Position pulse value is subject to electronic gear ratio of 1:1.
2. Unit of pulse quantity is the internal pulse unit of servo system. Pulse

quantity is represented with 5 digits higher + 5 digits lower, whose calculation method is as below:

Pulse quantity = value of 5 digits higher × 10000 + value of 5 digits lower
 Value of pulse quantity will not change any more when it reaches 327679999.
 The decimal point at top digit of Un 010, Un 012 and Un 014 means the value is negative.

For instance: Un010 is displayed as:



It means the value of Un010 is -3560000.

3. When the speed given by pulse is below electric gear ratio of 1:1, encoder shows the theoretical rotation speed of the gain type 2500 lines of electric motor.

4. Pulse numbers of encoder angles show the rotor's position in relate to stator in one complete revolution, one revolution is regarded as one cycle.

5. As for wire saving encoder motor, its encoder signal only represents the data during power on, the contents of non wire saving encoder signal display is shown in the following table:

Monitor No.	No. of digits	I/O	Contents displayed	Relevant I/O Signals
Un006	0	Input signal	Signal of Encoder W	2CN-12\13(PG-W)
	1		Signal of Encoder V	2CN-5\6(PG-V)
	2		Signal of Encoder U	2CN-10\11(PG-U)

6. Contents of I/O terminal signals are in the following table:

Monitor No.	No. of digits	I/O	Contents displayed	Relevant I/O Signals
Un005	0	Input signal	Servo ON	1CN-15 (/S-ON)
	1		Alarm reset	1CN-6(/ALM_RST)
	2		Clear error counter	1CN-7(/CLR)
	3		Zero position signal	1CN-17(/ZPS)
	4,5,6		No display	No signal
	7	Output signal	Servo alarm	1CN-4 (/ALM)
	8		Positioning complete(speed achieves)	1CN-3 (/COIN)

	9		Mechanical braking released	1CN-2 (/BRK)
--	---	--	-----------------------------------	--------------

The relative LED is lit to show some I/O signal is active.

6.2 Auxiliary functions

In Auxiliary Function Mode, some application operations can be done with the digital operator. The functions details are shown as below:

Function No.	Content	Other
Fn000	Display alarm history	Open operation
Fn001	Restore to factory settings	
Fn002	JOG operation	
Fn003	Automatic offset-signal adjustment of motor current detection	
Fn004	software version of servo	
Fn005	System runtime	Hidden operation
Fn006	Software version of panel operator	
Fn007	Factory test	
Fn008	Inertia inspection	

Notes:

1. Open operations refer to the auxiliary functions for general users.
2. Hidden operations:
When the panel operator is in simple code menu, press "xxxx" and start to use the auxiliary functions.

6.2.1 Alarm history display

The last ten(10) alarms are displayed in the alarm history library. Take following steps to check the latest alarm.

1. Press MODE key to select auxiliary function mode
2. Press INC or DEC to select function number of alarm history display.

Fn000

3. Press ENTER key, the latest alarm code is displayed.

Alarm No. Alarm code

0-R01

4. Press INC or DEC key to display other alarm codes occurred recently.

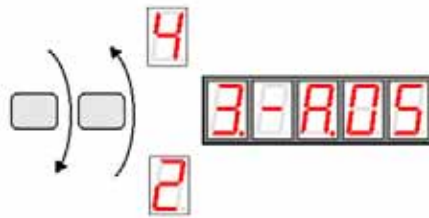

5. Press ENTER to return to function number display.



If an alarm occurs right now, the alarm codes will be updated immediately. The alarm with a serial number of 0 is the current alarm, and the alarm with a serial number of 9 is the last alarm.

If the user wants to clear all alarm history data, press ENTER key and hold on for one second while alarm codes are being displayed, then all alarm history is deleted.



6.2.2 Restore to factory settings

This function is used when returning to the factory settings after changing parameter settings.

1. Press MODE key to select auxiliary function mode.
2. Press INC or DEC key to select function number for restoring to factory settings.



3. Press ENTER to enter parameter restoring mode.



4. Press ENTER key and hold on for one second to restore all the parameters to default values.



5. Release ENTER key to return to function number display.



6. In Step 3, the parameter restoring operation can be cancelled and quit current operation by a short press on the ENTER key.

6.2.3 JOG operation

Note:

This mode is not available when servo is on or some alarm occurs.

Take following operation steps to make JOG operation.

1. Press MODE key to select auxiliary function mode.
2. Press INC or DEC key to select JOG Function number.



A four-digit red LED display showing the text "Fn002".

3. Press ENTER key to enter JOG mode, meanwhile, servo is OFF (motor power is OFF)..



A four-digit red LED display showing the text "FJOG".

4. Press MODE key to enable Servo ON /S-ON..



A four-digit red LED display showing the text "S-ON".

5. Press MODE key to turn servo ON and OFF.

If user wants to run motor, Servo On has to be used.

6. Press INC or DEC key, motor runs when pressing the keys.

The servomotor will rotate at the present setting speed as below.

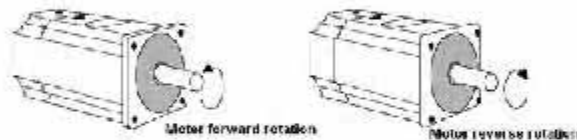

During motor's FWD or REV direction, LED display is as below:

Forward direction 

Reverse direction 

7. Press ENTER to return to function number display. At this moment, servo motor is turned OFF



A four-digit red LED display showing the text "Fn002".

6.2.4 Automatic offset signals adjustment of motor current detection

The servo drive will check motor current detection signals every time the servo is initializing upon power on and will adjust automatically if required, therefore, user needn't do any manual adjustment in normal situations. If the user thinks the torque is a bit too large by judging from motor current offset, user may manually adjust motor current to lower down the torque further or to get higher running accuracy. This section gives a know-how instruction on the operation steps to make offset signal automatic and manual adjustment.

Note:

The offset signal adjustment of motor current detection is only available when servo is OFF.

■ Adjust motor current detection offset signal automatically

Take following steps to make automatic offset adjustment.

1. Press Mode key to select auxiliary function mode.
2. Press INC or DEC key to select function number.



Fn003

3. Press ENTER key and enter automatic adjusting mode.



CurLo

4. Press MODE and hold on for one second, donE is displayed and glimmers, the offset signal is then adjusted automatically.

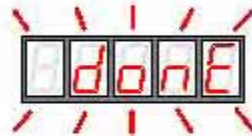

donE



Release the key



CurLo

5. Press ENTER key to return to function number display.



Fn003

6.2.5 Servo software version display

Take following steps to display software version of the servo drive.

1. Press MODE key and select Auxiliary Function Mode;
2. Press INC key or DEC key to select function number of software version display.



Fn004

3. Press ENTER key, current software version is displayed.



100

4. Press ENTER key again to return to function number display.



Fn004

6.2.6 System runtime

Take following steps to display system runtime.

1. Press MODE key and select Auxiliary Function Mode.
2. Press INC key or DEC key to select function number.

A digital display showing the text "Fn005" in red characters on a black background.

3. Press ENTER key to display system runtime.
Following picture shows system runtime is 1 hour and 28 minutes.

A digital display showing the time "01.28" in red characters on a black background.

4. Press ENTER key again to return to function number display.

A digital display showing the text "Fn005" in red characters on a black background.

The displayed time is the runtime after system is started up, the date is not refreshed in real time. If user wants to refresh the data, please repeat the operations in Step 3 and Step 4.

6.2.7 Software version of panel operator

Activate the hidden functions first before making operations in Section 6.2.7, 6.2.8 and 6.2.8.

Take following steps to display software version of the panel operator.

1. Press MODE key and select Auxiliary Function Mode;
2. Press INC key or DEC key to select function number..

A digital display showing the text "Fn006" in red characters on a black background.

3. Press ENTER key, current software version is displayed.

A digital display showing the software version "1.1.1" in red characters on a black background.

4. Press ENTER key again to return to function number display.

A digital display showing the text "Fn006" in red characters on a black background.

6.2.8 Factory test

6.2.9 Inertia inspection

Take following steps to make inertia inspection.

1. Press MODE key and select Auxiliary Function Mode;
2. Press INC key or DEC key to select function number..



3. Press ENTER key and go into inertia inspection page as shown below:



4. Press Mode key again to start inertia detection. Following page is displayed:



If servo alarm occurs or servo is ON, inertia inspection will not be executed, instead, a message "abort" is displayed on the panel operator as below.



If the user wants to cancel the function during inertia inspection or after entering the function menu, just press ENTER key.

5. When inertia inspection completes, inertia value of load and motor are displayed in the unit of $0.1 \text{ Kg}\cdot\text{m}^2 \times 10^{-4}$.



6. Press ENTER key again to return to function number display page.

Notes:

1. Please be very careful during inertia inspection operation, because motor will run forward and reverse for four(4) revolutions, meanwhile, motor is not controlled by external signals. Make sure the running stroke of load is within required range to avoid possible damage to user's equipments.
2. This operation is unavailable if servo is on or servo alarm occurs.

Chapter 7 Trial operation

7.1 Inspection and checking before trial operation

To ensure safe and correct trial operation, inspect and checking the following items before starting.

1. Wiring
 - All wiring and connections are correct.
 - The correct power supply voltage is being supplied to the main circuit and servomotor.
 - All groundings are good.
 - If trial operation only refers to JOG function, 1CN wiring will not be required. Refer to 3.1.2.
2. Check power supply specification and make sure input voltage is correct.
3. Fix servomotor securely
 - Fix servomotor on the base as secure as possible, to avoid the risk of

danger which is caused by the counterforce coming from motor speed change.

4. Remove motor load

In case servo drive or moving structures are damaged, or indirect person hurt or injury, make sure motor load is removed, including the connector and its accessories on the motor shaft.

7.2 JOG operation

No other wiring (such as 1CN) is required for trial JOG operation, it's suggested JOG operation is done with low speed.

If motor can run properly in JOG operation, which means motor and servo drive are in good condition, and their connection is correct.

If motor can not run, check connection of UVW and encoder cables. If motor runs improperly, check if the phase order of UVW cables is correct or not.

Notes:

1. Before JOG operation, make sure motor load is removed from 1CN.
 2. Load default parameters and initializes user parameters to factory settings.
 3. Power On again to start trial running.
-

With help of panel operator, follow the steps below and start JOG operation.

1. Turn on servo drive's power supply. Panel operator gives a display as below:

A four-digit red LED display showing the number 'F.0000'.

2. Press "MODE" key.

A four-digit red LED display showing the number 'Pn0000'.

3. Press "MODE" key again.

A four-digit red LED display showing the number 'Un0000'.

4. Press "MODE" key a third time to switch onto the menu for auxiliary functions.

A four-digit red LED display showing the number 'Fn0000'.

5. Press "INC" key and increase the value to 2.

A four-digit red LED display showing the number 'Fn0002'.

6. Press "ENTER" key and go into JOG operation mode.

E.0000

7. Press "MODE" key and select Servo On.

0.0000

8. Press "INC" key, motor runs counterclockwise. Press "DEC" key, motor runs clockwise. Motor speed depends on Pn032 setting. If the above key is released, motor should stop running.

Forward 0.0000

Reverse 0.0000

9. Press "MODE" key and select Servo OFF.

E.0000

10. Press "ENTER" key and exit JOG operation.

7.3 Trial operation in position control mode

1. Preparation

Check if 1CN cable, power cables of servo drive and servomotor, encoder cables are connected in the right way.

2. Operation steps

- 1) Set Parameter 008 according to output style of servo drive, set Pn041 as 0, then Power On again.
- 2) When Servo On is enabled (/S-On signal becomes active) , motor will keep in excitation status.
- 3) A low frequency signal is sent from host controller to servo drive, motor is set to run at low speed.
- 4) Check motor speed with panel operator by its Un000 display, or monitor motor speed with host controller. Make sure feedback speed of servomotor agrees with the setting value.
Inspection: When reference pulse stops, motor should stop running.

Relation between motor speed and pulse frequency input.

Input pulse frequency (Hz) pulse+direction	Motor frequency (r/min)	other
500K	3000	Electronic gear ratio is 1: 1; line number of motor encoder is 2500ppr.
250K	1500	
100K	600	
50K	300	

Chapter 8 Communication

8.1 RS232 communication hardware structure

EDC servo drive supports RS232 communication. Via the RS232 COM function in its front panel, parameters reading out or writing in and system status monitoring are available.

8.1.1 External connection diagram

Following diagram shows external connection between servo drive and PC.



8.1.2 Cable connection

Following illustration shows the plug shape of the RS232 COM port on EDC servo drive.

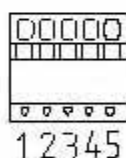

See the signal definition details in the following table:

Pitch	Signification
1	VCC, internal 5V power supply of servo drive
2	TX, RS232 COM transmission foot
3	RX, RS232 COM receiving foot
4	GND, grounding of internal power supply of servo drive
5	FG, connect the shield layer of COM to the earth.

Following diagram shows how to connect a PC to EDC's COM port.

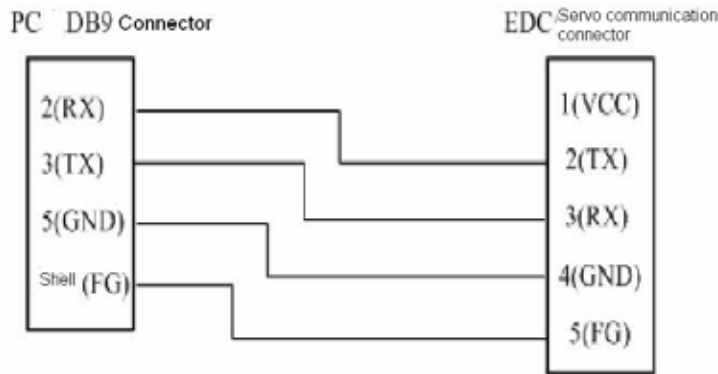

Notes:

1. Depending on different environment situations and communication speeds, effective communication distance also varies. When communication baudrate exceeds 38400bps, a communication cable within one(1) meter long is required to ensure transmission accuracy.
2. It's suggested shielded cables are used for communication, subject to the two shield layers are connected to their own pitches.
3. When external interface is RS422 or RS485, it's required to use external converting module for connection to servo drive.

8.2 Communication relevant parameters

When the value 0 is selected as the panel shaft number of EDC servo drive, then servo drive is able to communicate with panel operator and PC via Estun company's internal protocol, which has nothing to do with the communication parameters Pn060, Pn061 or Pn062.

When the values in the range of 1~E is selected as the panel shaft numbers, MODBUS communication function should also be enabled, then it's available for EDC servo drive to communicate with ESVIEW software. The selected panel shaft number is the communication address. The speed is set according to Pn061 settings, and the communication protocol is set according to Pn062 settings. Only when the value F is selected as the panel shaft number, shaft number address Pn060 is used by the servo drive.

1、COM address

Parameter	Name	Unit	Setting range	Factory setting
Pn060	COM address	—	1~254	1

When the dial switch on the drive panel is set as F, this parameter is used as the communication address.

2、COM speed

Parameter	Name	Unit	Setting rang	Factory setting
Pn061	RS232 COM speed 0 : 4800bit /s 1 : 9600bit /s 2 : 19200b it/s	bps	0~2	1

When communication function is used, same communication speed between host controller and servo drive is required.

3、COM protocol

Parameter	Name	Unit	Setting rang	Factory setting
Pn062	RS232 COM protocol 0 : 7 , N , 2 (Modbus,ASCII) 1 : 7 , E , 1 (Modbus,ASCII) 2 : 7 , O , 1 (Modbus,ASCII) 3 : 8 , N , 2 (Modbus,ASCII) 4 : 8 , E , 1 (Modbus,ASCII) 5 : 8 , O , 1 (Modbus,ASCII) 6: 8, N, 2(Modbus,RTU) 7: 8, E, 1(Modbus,RTU) 8 : 8 , O , 1 (Modbus,RTU)	---	0~8	5

This parameter decides which COM protocol to be used, the number 7 or 8 means digit numbers of data for data transmission is 7 digits or 8 digits. English alphabet N, E and O means odd or even. N means this digit is disabled, E means 1 digit even, O means 1 digit odd, the number 1 or 2 means stop is 1 digit or 2 digits.

The communication protocol between host controller and servo drive are required to be the same when communication function is used.

4、COM input IO control

When using COM control function, the parameter Pn059 can be used to shield input IO signals if the user does not want external input signals to affect servo drive. When some bit is set as (0)zero, the signal of this bit is then controlled by the external input signal. If the bit is set as 1, then COM control is applied to this bit.

Parameter	Name	Unit	Setting rang	Factory setting
Pn059	COM input IOcontrol	---	0~15	0

This parameter is used to set whether the number input of servo drive is controlled by external IO or by COM. When the parameter is set as zero, it means all numerical IO input pitches are controlled by external signals. When it is set as 15, it means all of the four IO inputs are COM controlled, and all external input signals are ignored.

input signal source is decided by value of Pn059:

Pn059	Comments on every bit
BIT0	Decides SON (1CN-15) source of signal input: 0: controlled by external input signal 1: controlled by COM
BIT1	Decides ALM-RST (1CN-6) source of signal input: 0: controlled by external input signal 1: controlled by COM
BIT2	Decides CLR(1CN-7)source of signal input: 0: controlled by external input signal 1: controlled by COM
BIT3	Decides ZPS (1CN-17) source of signal input: 0: controlled by external input signal 1: controlled by COM

Following are the two ways for COM function to operate on digital input IO signals:

1. Change the value of Pn054 directly, inverts required signal and enables it.
2. Set Pn059 first, to make servo ignore external input signal, then write in corresponding value to the data whose address is 0x00F5 when controlling of external input signal is required. The value of the data whose address is

0x00F5 is not saved after a power interruption.

The table below gives an instruction of the value of the data whose address is 0x00F5.

Value of data whose address is 0x00F5	Comments on every bit
BIT0	Decides SON (1CN-15) signal: 0: signal is invalid 1: signal is valid
BIT1	Decides ALM-RST (1CN-6) signal: 0: signal is invalid, S-OFF 1: signal is valid
BIT2	Decides CLR (1CN-7) signal: 0: signal is invalid, S-OFF 1: signal is valid
BIT3	Decides ZPS (1CN-17) signal: 0: signal is invalid, S-OFF 1: signal is valid

For example, when COM is used control IO signals of external input, set Pn059 as 15, which means all external digital input IO are controlled by COM. When servo On is required, write in the value 1 to servo drive's 0x00F5 address.

8.3 MODBUS communication protocol

When axis number on front panel of EDC servo drive is not selected as zero, MODBUS protocol is used for communication. There're two modes available in MODBUS communication, that is ASCII Mode (American Standard Code for information interchange) or RTU (Remote Terminal Unit) mode. See pages below for a simple introduction of these two communication modes.

8.3.1 Code signification

ASCII mode:

Each 8-bit data consists of two ASCII characters. Here's an example of a 1-byte data 64H expressed in hex system, if the data is expressed in ASCII mode, it includes ASCII code of 6 (36H) and ASCII code of 4 (34H) .

Follow table shows the ASCII code from 0 to 9 and from A to F.

Character	'0'	'1'	'2'	'3'	'4'	'5'	'6'	'7'
-----------	-----	-----	-----	-----	-----	-----	-----	-----

sign								
ASCII code	30H	31H	32H	33H	34H	35H	36H	37H
Character	'0'	'1'	'2'	'3'	'4'	'5'	'6'	'7'
sign								
ASCII code	38H	39H	41H	42H	43H	44H	45H	46H
Character	'8'	'9'	'A'	'B'	'C'	'D'	'E'	'F'

RTU mode:

Each 8-bit data consists of two 4-bit data expressed in hex system. For example, the number 100 in decimal system will be expressed as 64H if RTU data of 1 byte is used.

Data structure:

10bit character format (for 7-bit data)

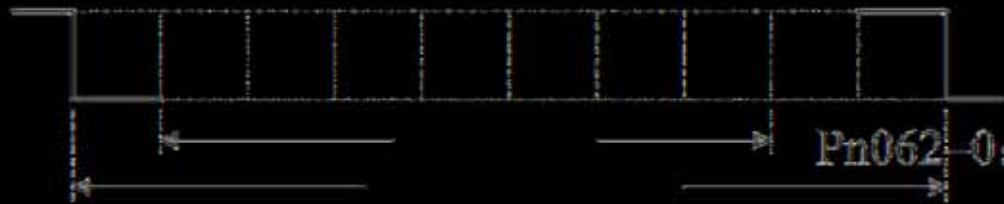
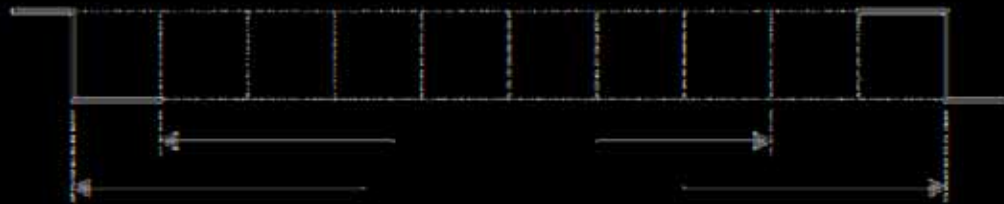
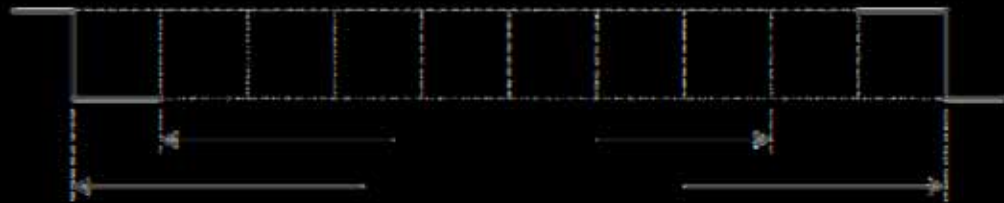

Pn062=0: 7, N, 2 (Mod)

11bit character format (for 8-bit data)



7-data bits

10- bits character

Start

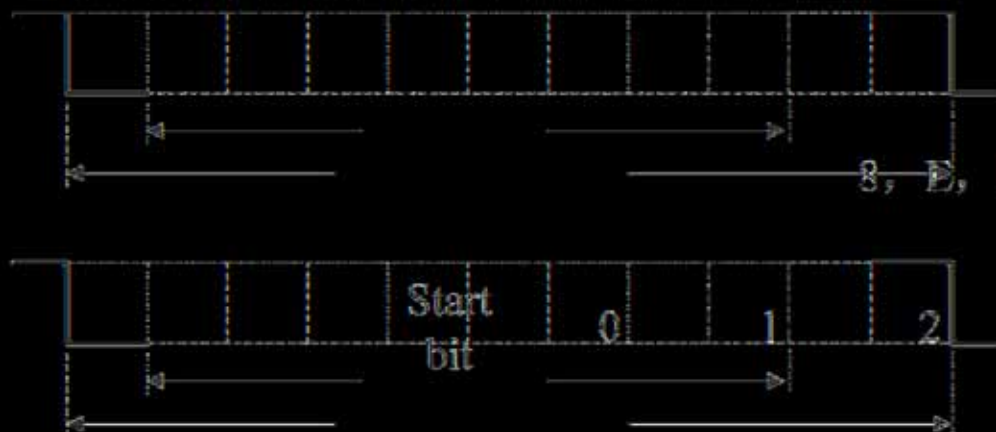

Communication protocol structure:
 Data format of communication protocol:
 ASCII mode:

8-data bits
 11- bits character frame

STX	Start bit: '=>(3AH)
ADR	COM address=>1-byte including two ASCII codes
CMD	Reference code=>1-byte including two ASCII codes
DATA(n-1)	Data contents => n-word=2n-byte including four ASCII code, no more than 12
.....	
DATA(0)	
LRC	Checkout code=>1-byte including two ASCII codes
End 1	stop bit1=> (0DH) (CR)
End 0	stop bit0=> (0AH) (LF)

8-data bits
 11- bits character frame

RTU mode:

STX	Freeze time for transmission time of over 4 bytes at current transmission speed
ADR	COM address=>1-byte
CMD	Reference code=>1-byte
DATA(n-1)	Data content=>n-word=2n-byte, n is no more than 12
.....	
DATA(0)	
CRC	CRC checkout code=>1-byte
End 1	Freeze time for transmission time of over 4 bytes at current transmission speed

See followings for an introduction on data format of COM protocol.

STX (COM start)

ASCII mode: ' 'byte.

RTU mode: Freeze time for transmission time of over 4 bytes (which varies automatically according to changing of communication speed)

ADR (COM address)

Range of legal COM address: from 1 to 254

The example below shows communication with a servo whose address is 32, if expressed in hex system the address will be 20.

ASCII mode: ADR='2', '0'=>'2'=32H, '0'=30H

RTU mode: ADR=20H

CMD (Command reference) and DATA (Data)

Data format depends on following command codes:

Command code: 03H, when reading N words, maximum value of N is 20.

For example, read the first two words from start address 0200H from a servo at the address of 01H.

ASCII mode:

Reference information:

STX	';
ADR	'0'
	'1'
CMD	'0'
	'3'
Start information address	'0'
	'2'
	'0'
	'0'
information quantity by "word"	'0'
	'0'
	'0'
	'2'
LRC examine	'F'
	'8'
End 1	(0DH)(CR)
End 0	(0AH)(LF)

Response information:

STX	';
ADR	'0'
	'1'
CMD	'0'
	'3'
info amount (by byte)	'0'
	'4'
start info address. the comment of 0200H	'0'
	'0'
	'B'
	'1'
The second info address	'1'
	'F'
The comment of 0201H	'4'
	'0'
	'0'
LRC examine	'E'
	'8'
End 1	(0DH)(CR)
End 0	(0AH)(LF)

RTU mode:

Reference information:

Response information:

ADR	01H
CMD	03H
Start info. address	02H ^(High bit of address)
	00H ^(Low bit of address)
Info. quantity by (word)	00H
	02H
CRC ^{Low bit of examination}	C5H ^(Low bit of examination)
CRC ^{High bit of examination}	B3H ^(High bit of examination)

ADR	01H
CMD	03H
Info quantity By word	04H
Start info address comment of 0200H	00H ^(High bit of data)
	B1H ^(Low bit of data)
The second info. address comment of 0201H	1FH ^(High bit of data)
	40H ^(Low bit of data)
CRC ^{low bit of examination}	A3H ^(Low bit of examination)
CRC ^{High bit of examination}	D3H ^(High bit of examination)

Reference code: 06H, write in one word.

For instance, write 100(0064H) into 01H servo at the address of 0200H.

ASCII mode:

Reference information:

STX	‘:’
ADR	‘0’
	‘1’
CMD	‘0’
	‘6’
Start info. address	‘0’
	‘2’
	‘0’
	‘0’
Comment of info.	‘0’
	‘0’
	‘6’
	‘4’
LRC examine	‘9’
	‘3’
End 1	(0DH)(CR)
End 0	(0AH)(LF)

Response information:

STX	‘:’
ADR	‘0’
	‘1’
CMD	‘0’
	‘6’
Info. address	‘0’
	‘2’
	‘0’
	‘0’
Info. address comment of 0200H	‘0’
	‘0’
	‘6’
	‘4’
LRC examine	‘9’
	‘3’
End 1	(0DH)(CR)
End 0	(0AH)(LF)

RTU mode:

Reference information:

ADR	01H
CMD	06H
Start info. address	02H ^(high bit of address)
	00H ^(low bit of address)
Comment of info.	00H ^(high bit of data)
	64H ^(high bit of data)
CRC ^{low bit of examination}	89H ^(low bit of examination)
CRC ^{high bit of examination}	99H ^(high bit of examination)

Response information:

ADR	01H
CMD	06H
Start info. address	02H ^(high bit of address)
	00H ^(low bit of address)
Info. comment	00H ^(high bit of data)
	64H ^(low bit of data)
CRC ^{low bit of examination}	89H ^(low bit of examination)
CRC ^{high bit of examination}	99H ^(high bit of examination)

Take following steps to calculate value of LRC (ASCII mode) and CRC(RTU mode) .

LRC calculation in ASCII mode

In ASCII mode, LRC (Longitudinal Redundancy Check) is used. LRC value is calculated according to following way: first make a sum result of the values from ADR to contents of a finishing stroke, then the result is divided by 256, later on, take away the part that goes beyond, after that calculate its fill-in number, final result will be the LRC value.

Following example shows the steps to read a word from 01H servo drive at the address of 0201.

STX	':'
ADR	'0'
	'1'
CMD	'0'
	'3'
Start info. address	'0'
	'2'
	'0'
	'1'
Info. quantity by word	'0'
	'0'
	'0'
	'1'
LRC examine	'F'
	'8'
End 1	(0DH)(CR)
End 0	(0AH)(LF)

Sum ADR's data from beginning to the last data:

$$01H+03H+02H+01H+00H01H=08H$$

Take fill-in number of 2 from 08H, therefore LRC is 'F', '8'.

CRC calculation in RTU mode

CRC (Cyclical Redundancy Check) error detection value is used in RTU mode. Take following steps to calculate CRC error detection value.

Step 1: Load in a 16-bit register whose content is FFFFH, which is called CRC register.

Step 2: Make OR calculation of the 1st bit (bit0) of reference information and the low bit (LSB) of 16-bit CRC register, then save the result into CRC register.

Step 3: Check lowest (LSB) of CRC register, if this bit is 0, then move the value to the right for one digit. If this bit is 1, then move the value to the right for one digit, after that, make OR calculation with A001H.

Step 4: Go back to Step3, when knows Step 3 has been done eight times, moves on to Step5.

Step 5: Repeat operations from Step 2 to Step 4 for the next bit of reference information, when knows all bits have been processed in the same way, the wanted CRC error detection value is just the current content in the CRC

register.

Instruction:

After CRC error detection value is calculated, it's required to fill in first the low bit of CRC in reference information, then fill in the high bit of CRC. Refers to the example below.

Example:

Read two words from 0101H address of 01H servo drive. Final content of CRC register is calculated and turns to be 3794H by summing the data from ADR to last bit, then its reference information is shown below. Please be noticed 94H should be transmitted before 37H.

ADR	01H
CMD	03 H
Start info. address	01 H ^(high bit of address)
	01 H ^(low bit of address)
Info. quantity by word	00H ^(high bit of data)
	02 H ^(low bit of data)
CRC ^{low bit of examination}	94 H ^(low bit of examination)
CRC ^{high bit of examination}	37 H ^(high bit of examination)

End1、End0 (Communication complete)

ASCII mode:

Communication ends with the character '\r' [carriage return] and (0AH) '\n' [new line] .

RTU mode:

The freeze time for communication time required by four bytes at a speed exceeding current communication speed means communication comes to an end.

For example:

Use C language to generate CRC value. This function needs two parameters:

unsigned char * data;

unsigned char length;

This function will transmit back CRC value of unsigned integer.

```
unsigned int crc_chk(unsigned char * data,unsigned char length){
```

```
    int i,j;
```

```
    unsigned int crc_reg=0xFFFF;
```

```
    While(length- -){
```

```
        crc_reg ^=*data++;
```

```
        for(j=0;j<8;j++){
```

```
            If(crc_reg & 0x01){
```

```
                crc_reg=( crc_reg >>1)^0xA001;
```

```
            }else{
```

```
                crc_reg=crc_reg >>1;
```



```

    }
  }
}
return crc_reg;
}

```

8.3.2 Communication error handling

Error may occur during communication. Normal error sources are as below:

- When reading and writing parameters, data address is incorrect.
- When reading parameters, data value is higher than this parameter's maximum value or lower than its minimum value.
- Communication is disturbed, data transmission error or checking code error.

When above communication error occurs, it does not affect running of servo drive, meanwhile, the drive will give a feedback of error frame.

The format of error frame is shown in following table.

Data frame of host controller:

start	Slave station address	command	Data address, references, etc.	checkout

Servo drive's feedback of error frame:

start	Slave station address	Response code	Error code	checkout

Comments:

Error frame response code = Command + 80H;

Error code = 00H: communication is good

= 01H: servo drive can't identify requested function

= 02H: given data address in the request does not exist in servo drive

= 03H: given data in the request is not allowed in servo drive (higher than maximum value or lower than minimum value of the parameter)

= 04H: servo drive has started processing the request, but unable to finish this request.

For example:

Let's suppose the axis number of servo drive is 03H, and we want to write data 06H into Parameter Pn002. Because maximum and minimum value of Pn002 are both zero(0), the data which is to be written in will not be accepted, instead, servo drive will feedback an error frame with error code 03. The frame is as

below:

Data frame of host controller:

start	Slave station address	command	Data address, references, etc.	checkout
	03H	06H	0002H 0006H	

Servo drive's feedback error frame:

start	Slave station address	Response code	Error code	checkout
	03H	86H	03H	

Plus, if the slave station address of data frame transmitted by Host controller is 00H, it means this frame of data is broadcasting data, and servo drive will not feedback a frame.

8.3.3 Parameters, servo status data communication address

In MODBUS communication mode, all the communication parameters of EDC servo are shown in the following table:

Address of communication data	Meaning	Comments	Operation
0000~0078H	Parameter area	Parameters in corresponding parameter table	Readable and writable
0806~0814H	Monitored data (consistent with data displayed on handheld operator or drive panel)		Read only
0806H	Speed feedback	Unit: r/min	read only
0807H	Input speed reference value	Unit: r/min	read only
0808H	Percentage of Input torque reference	Relatively rated torque	read only
0809H	Percentage of Internal torque reference	Relatively rated torque	read only

080AH	Pulse number of Encoder rotation		read only
080BH	input signal status		read only
080CH	status of encoder signal		read only
080DH	status of output signal		read only
080EH	Pulse given		read only
080FH	Current position low	Unit: 1 reference pulse	read only
0810H	Current position high	Unit: 10000 reference pulse	read only
0811H	error pulse counter low 16 position		read only
0812H	error pulse counter high 16 position		read only
0813H	Given pulse counter low	Unit: 1 reference pulse	read only
0814H	Given pulse counter high	Unit: 10000 reference pulse	read only
0817H	Current alarm		read only
07F1~07FAH	Alarm information storage area	10 History Alarms	read only
0900H	IO signal of ModBus Communication	No saving in case of power interruption	readable and writable
0901H	Drive status		read only
0904H	Runtime of servo drive	Unit: minute	read only
090EH	DSP software version	Version expressed in number	read only
1000H	Drive model	Host controller reads information from servo drive	read only
1021H	Reset History Alarm	01: Reset	readable and writable
1022H	Reset current alarm	01: Reset	readable and

			writable
1023H	JOG Servo ON	01: enable 00: disable	readable and writable
1024H	JOG forward run	01: forward run 00: stop	readable and writable
1025H	JOG reverse run	01: reverse run 00: stop	readable and writable

Notes:

1、 parameter area (COM address is from 0000 to 0078H)

Parameters in related parameter table, for example, parameter with 0000H as COM address is expressed as Pn000, parameter with 0065H as COM address is expressed as Pn101, and read-write of data at 0000H is the same as operating on parameter Pn000. If data coming from communication is not within the parameter range, the data will be abandoned and servo drive will feedback a message of operation fail. If the parameter is changed successfully, this parameter will be saved automatically after a power interruption.

2、 Monitoring data area (0806~0814H)

The monitoring data does not correspond totally to display of Un000~Un013on handheld operator. For example, the data that communication reads from address of 0807H is FB16H, then specified speed is -1258 r/min.

Following table shows the meaning of each monitoring data.

Monitored data	Comments	
0806H	Actual motor speed: r/min	
0807H	Input speed reference value: r/min	
0808H	Feedback torque percentage % (Relatively rated torque)	
0809H	Input torque percentage % (Relatively rated torque)	→ 
080AH	Encoder angle pulse number	
080BH	input signal monitor	→
080CH	Encoder signal monitor	
080DH	Output signal monitor	
080EH	Pulse given speed (when electronic gear ratio is 1: 1)	
080FH	Current motor position is 5 digit low (×1 pulse)	

0810H	Current motor position is 5 digit high (×10000pulse)
0811H	position error 5 digit low (×1 pulse)
0812H	position error 5 digit high (×10000 pulse)
0813H	Position reference 5 digit low (×1 pulse)
0814H	Position reference 5 digit high (×10000pulse)

Monitoring of I/O signals is shown below:

Monitoring No.	Digit number	IO	Contents	Relative IO signal
080BH	0	input signal	Servo ON	1CN-15 (/S-ON)
	1		alarm reset	1CN-6(/ALM_RST)
	2		Clear counter error	1CN-7(/CLR)
	3		zero position signal	1CN-17(/ZPS)
080DH	0	output signal	servo alarm	1CN-4 (/ALM)
	1		positioning complete (speed arrives)	1CN-3 (/COIN, etc)
	2		mechanical brake release	1CN-2 (/BRK, etc)

2、Alarm memory block (07F1~07FAH)

History Alarm No.	Meaning	Address
0	History Alarm 1 (Latest alarm)	07F1H
1	History Alarm 2	07F2H
2	History Alarm 3	07F3H
3	History Alarm 4	07F4H
4	History Alarm 5	07F5H
5	History Alarm 6	07F6H
6	History Alarm 7	07F7H
7	History Alarm 8	07F8H
8	History Alarm 9	07F9H
9	History Alarm 10	07FAH

	(longest time)	

2、ModBus communication IO signal (0900H)

Use communication to control input digital IO signals, the data is not saved after power is interrupted.

5、System status (0901H)

1-word shows current system status.

The following illustration shows the meaning of each digit.

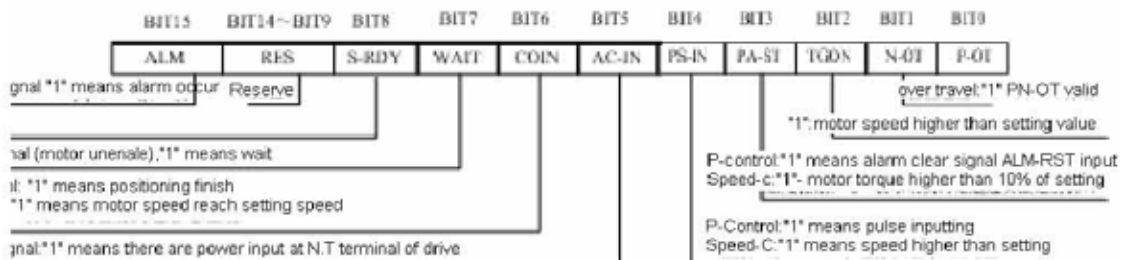

EDC servo drive's default speed is 10% of rated motor speed.

6、Run time (0904H)

It means the run time required from servo power on to read this data. It's expressed in decimal system and the unit is minute. If the read data is 00CDH, and it's expressed as 205 in decimal system, then it means current system has run for 3 hours and 25 minutes.

7、DSP Software Version (090EH)

DSP software version of servo drive is expressed in numbers. If the read data is 00C9H, and it's expressed as 200 in decimal system, then it means the software version is 2.00.

Notes:

- 1、 After COM address is changed, that is, parameter Pn060 or the dialing switch on drive panel is changed, servo drive will feedback data using current COM address until new COM address is updated and becomes available in around 40ms.
- 2、 After communication speed is changed, that is, parameter Pn061 is changed, servo drive will feedback data using current communication speed until new speed is updated and becomes available in around 40ms.
- 3、 After communication protocol is changed, that is, parameter Pn062 is changed, servo drive will feedback data using current communication protocol until new protocol is updated and becomes available in around 40ms.

4、 In RTU communication mode, intervals between data frames are longer than 10ms.

Chapter 9 Technical specification and features

9.1 Servomotor

9.1.1 Technical specification and features

■EMS series servomotor specification and model description

Rated time: continuous	Isolation class: F
Vibration class: V15	Withstand voltage: AC1500 V
Isolation resistor: 5DC50V 10MΩ (minimum)	
Protection method: fully-closed, self cooling IP67 (except for shaft opening)	
Ambient temperature: 0~40℃ (non-condensing)	Ambient humidity: 20% to 80%
Excitation: permanent magnet	Connection method: direct
Mounting: flange mounted	

■ EMS type 60 series

Motor model EMS-		02AH□□-Z006	04AH□□-Z013
Matched drive model EDC-		02PS-Z006	04PS-Z013
Rated output	W	200	400
Rated torque	N·m	0.637	1.273
Instantaneous Peak Torque	N·m	1.911	3.819
Rated current	Arms	1.265	2.497
Rated speed	rpm	3000	
Max. speed	rpm	3600	
Rotor inertia	$\text{Kg}\cdot\text{m}^2\times 10^{-4}$	0.138	0.261

Mechanical time constant	ms	1.52	1.08
Electrical time constant	ms	1.95	2.23
Mess	Kg	0.99	1.39

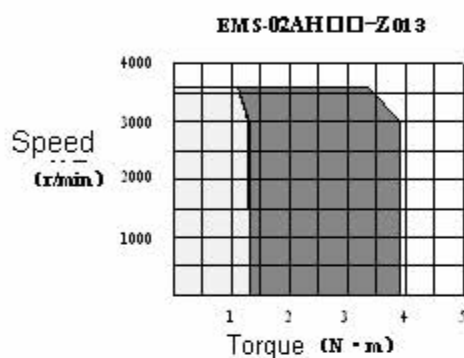
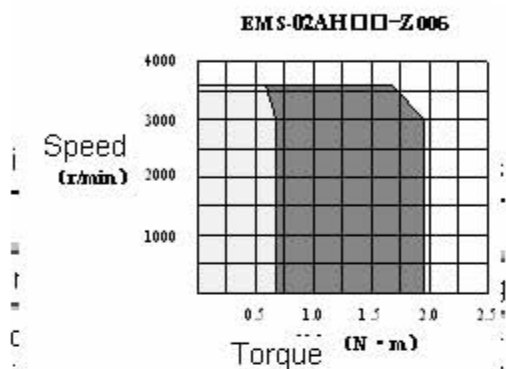

■ EMS type 80 series

Motor model EMH-		05AH□□-A016	08AH□□-A024
Matched drive model EDC-		05PS-A016	08PS-A024
Rated output	W	500	750
Rated torque	N·m	1.59	2.39
Instantaneous Peak Torque	N·m	4.78	7.16
Rated current	Arms	3.14	4.71
Rated speed	rpm	3000	
Max. speed	rpm	3600	
Rotor inertia	$\text{Kg}\cdot\text{m}^2 \times 10^{-4}$	0.843	1.78
Mechanical time constant	ms	0.266	0.280
Electrical	ms	2.06	2.30

time constant			
Mess	Kg	2.4	2.9

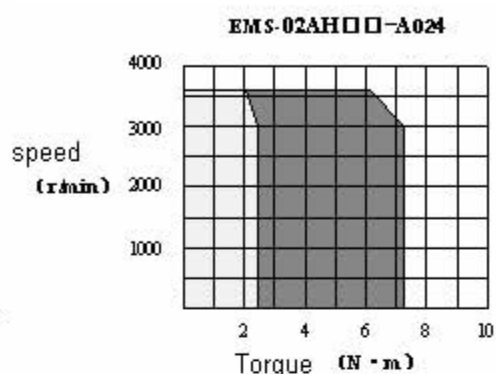
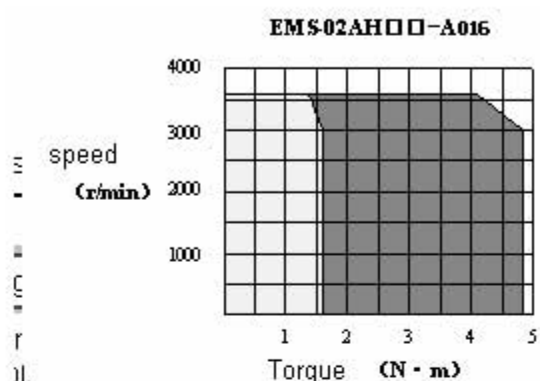

■ EMS type 90 series

Motor model EMS-		08AH□□-C024
Matched drive model EDC-		08PS-C024
Rated output	W	750
Rated torque	N·m	2.40
Instantaneous Peak Torque	N·m	7.1
Rated current	Arms	4.00
Rated speed	rpm	3000
Max. speed	rpm	3600
Rotor inertia	$\text{Kg}\cdot\text{m}^2 \times 10^{-4}$	2.6
Mechanical time constant	ms	0.12
Electrical time constant	ms	1.79
Mess	Kg	3.0

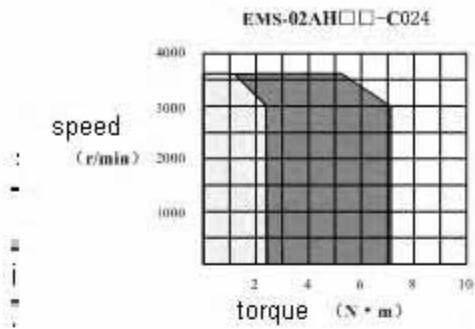

9.1.2 Servomotor mounting dimension

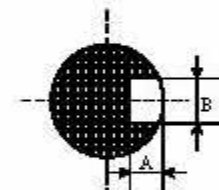
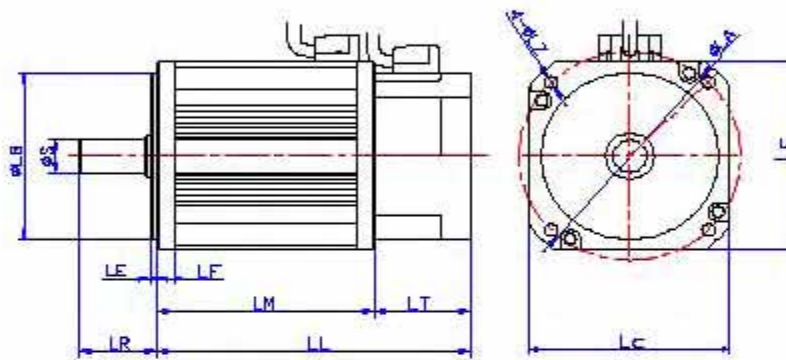

Motor model	LA	LB	LC	LE	LF	L M	LZ	S	LR	LL	LT	A	B
EMS-02AH□□-Z00	70	50	60	3	7	56	Φ4.5	Φ1	30	96	40	3	5
6	70	50	60	3	7	81	Φ4.5	4	30	121	40	3	5
EMS-04AH□□-Z01	90	70	80	3	13	88	Φ5.5	Φ1	35	129	41	4	6
3	90	70	80	3	13	10	Φ5.5	4	35	147	41	4	6
EMS-05AH□□-A01	100	80	90	3	9	6	Φ6.0	Φ1	35	139	41		
6						97		9					
EMS-08AH□□-A02								Φ1					
4								9					
EMS-08AH□□-C02								Φ1					
4								6					

9.1.3 Servomotor connection diagram

Cable specification

Motor model	Drive model	Encoder cable	Power cable
EMS-02AH□□-Z006	EDC-04PS-Z00 6	CMP-ZB26-□□	CDM-ZB18-□□
EMS-04AH□□-Z013	EDC-04PS-Z01 3	CMP-ZB26-□□	CDM-ZB18-□□
EMS-05AH□□-A016	EDC-05PS-A01 6	CMP-ZB26-□□	CDM-ZB18-□□
EMS-08AH□□-A024	EDC-08PS-A02 4	CMP-ZB26-□□	CDM-ZB18-□□
EMS-08AH□□-C024	EDC-08PS-C02 4	CMP-SB26-□□	CDM-SB18-□□

EDC servo drive series and EMJ servo motor series Connection:



电机插头接线规格

Motor Connector Specification

- 插头Plug: 172167-1(AMP)
- 针 Pin: 170360-1(AMP)

针号 Pin No.	信号 Signal	颜色 Color
1	U	红 Red
2	V	蓝 Blue
3	W	白 White
4	FG	绿/黄 Green/Yellow



制动器插头接线规格

Brake Connector Specifications

- 插头Plug: 172165-1(AMP)
- 针 Pin: 170360-1(AMP)

针号 Pin No.	信号 Signal	颜色 Color
1	B1	蓝 Blue
2	B2	白 White



编码器插头接线规格

Encoder Connector Specification

- 插头 Plug: 172169-1(AMP)
- 针 Pin: 170359-3(AMP)

增量式编码器

Incremental Encoder

针号 Pin No.	信号 Signal	颜色 Color
1	A+	蓝 Blue
2	B+	绿 Green
3	C+	黄 Yellow
4	A-	蓝/黑 Blue/Black
5	B-	绿/黑 Green/Black
6	C-	黄/黑 Yellow/Black
7	PG5V	红 Red
8	PG0V	黑 Black
9	FG	屏蔽 Shield

9.2 Servo drive

9.2.1 Technical specification and model

Servo drive model EDC-	01P	02P	05P	08P
Applicable servomotor model EMx-	01A	02A	05A	08A

Basic data	Power supply		Single phase AC220V $^{+10}_{-15}$ %,50/60Hz
	Control mode		SVPWM
	Feedback		Incremental encoder (2500P/R)
	Working Condition	Operating/ storage temperature	0~55°C/-20~85°C
		Operating/ storage humidity	Below 90%RH (non-condensing)
		Shock/vibration resistance	4.9m/s ² /19.6 m/s ²
	Structure		Base mounted
Mass (approximately)		2kg	
Speed control mode	Speed control range		1:5000
	Speed regulation	Load Regulation	0~100%: 0.01% below (at rated speed)
		Voltage regulation	Rated voltage $\pm 10\%$: 0%(at rated speed)
		Temperature regulation	0~40°C: 0.1% below(at rated speed)
Frequency Characteristics		250Hz (when $J_L \leq J_M$)	
Position control mode	Pulse reference	Type	SIGN+PULSE train, sin. Pulse phase A and phase B, CCW+CW pulse train
		Pulse Buffer	Line driving (+5V level), open collector (+5V、+12V、+24V level)
		Pulse Frequency	Max. 500Kpps (difference) / 200 Kpps (collector)
Control signals		CLEAR	
I/O signals	Pulse output signal		Phase A, phase B and phase C: line driving output
	Sequence control input		Servo ON, Alarm Reset, error counter clear signal, zero clamp signal.
	Sequence control output		Servo Alarm, positioning complete(speed coincidence), brake release, limiting torque
Built-in function	Dynamic braking		Built-in
	Protection		Power module error,overload, overspeed,voltage error, position error counter overflow, encoder disconnected, parameter damaged, etc.
	COM function		With RS232 interface for communication with host controller's special software, Parameter setting, Run operation and status display can be done in Windows mode. Same functions are enabled using panel operator. Compatible with Modbus communication protocol.

		CanOpen COM
	LED display	Charge indicator, Power&ALM indicator, five 7 segment tube (on panel operator)

9.2.2 Servo drive mounting dimension

With cooling fan

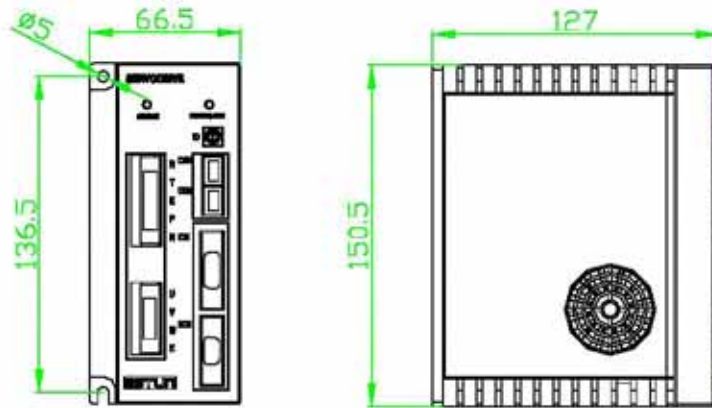

Without cooling fan

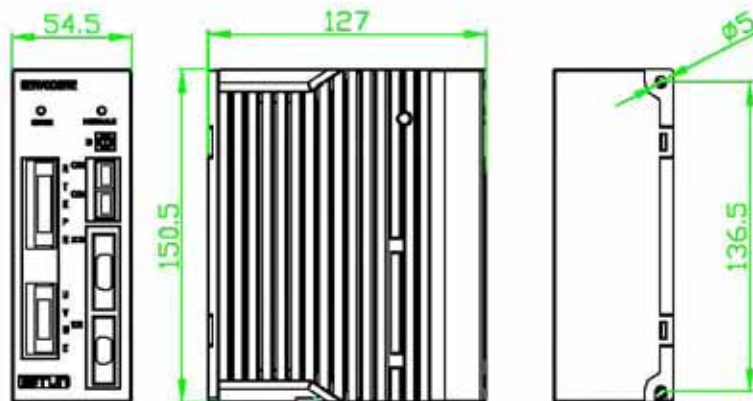

Appendix A

Parameter list

Para. No.	Name and Meaning	Unit	Setting range	Factory setting	Remarks
Pn000	Enable/Disable Servo On input signal (/S-ON) [0] Enable Servo ON input	—	0~1	0	①

Para. No.	Name and Meaning	Unit	Setting range	Factory setting	Remarks
	signal (/S-ON) [1] Enable internal servo ON (/S-ON)				
Pn001	Enable/Disable input signal prohibited (PN-OT) When 1CN-2 is set as PN-OT signal, limiting direction and enabling are selected according to this parameter. [0]disable input signal prohibited [1]enable forward run input signal prohibited [2]enable reverse run input signal prohibited	—	0~2	0	①
Pn002	Reserved	—	0	0	
Pn003	Select operation upon momentary power interruption [0] Servo alarm output is not available (ALM) [1] Servo alarm output is available (ALM)	—	0~1	0	①
Pn004	Stopping method for servomotor after Servo OFF or alarm occurrence [0] Stop the motor by applying DB (dynamic brake) [1] Stop the motor by coasting [2] Stop the motor by applying DB (dynamic brake), then the motor coasts to a stop [3] Stop the motor by coasting without using DB	—	0~3	0	①
Pn005	Clear error pulse signal is turn ON or not after Servo OFF [0] Turned on [1] turned off	—	0~1	0	①
Pn006	Select rotation direction [0] side view from load of servomotor , CCW means forward run	—	0~1	0	①

Para. No.	Name and Meaning	Unit	Setting range	Factory setting	Remarks
	[1] side view fromload of servomotor, CW means forward run				
Pn007	Speed control mode selection [0] ADRC control [1] PI control	—	0~1	0	
Pn008	Reference pulse form [0] SIGN + PULSE [1] CW+CCW [2] Phase A + Phase B (×4), positive logic	—	0~2	0	①
Pn009	Reference pulse form [0] does not invert PULSE reference, does not invert SIGN reference [1] does not invert PULSE reference, inverts SIGN reference [2] inverts PULSE reference, does not invert SIGN reference [3] inverts PULSE reference, inverts SIGN reference	—	0~3	0	①
Pn010	PG pulse dividing ratio	P/R	1~2500	2500	①
Pn011	Dividing output phase selection	—	0~1	0	①
Pn012	Speed feedforward selection [0] disable [1] enable	—	0~1	0	
Pn013	Speed loop gain	Hz	1~3000	80	②
Pn014	Speed loop integral time constant	ms	1~2000	180	②
Pn015	Position loop gain	1/s	1~1000	40	
Pn016	Speed error	r/min	0~300	0	
Pn017	Position feedforward	%	0~100	0	
Pn018	Torque reference filter	%	0~5000	0	
Pn019	Soft start acceleration time	ms	0~10000	100	
Pn020	Soft start deceleration time	ms	0~10000	100	
Pn021	S-shaped acceleration and deceleration time	ms	0~1000	0	
Pn022	Electronic gear ratio (numerator)	—	1~32767	1	
Pn023	Electronic gear ratio	—	1~32767	1	

Para. No.	Name and Meaning	Unit	Setting range	Factory setting	Remarks
	(denominator)				
Pn024	1 st position reference filter	ms	0~1000	0	
Pn025	Feedback filter	ms	0~1000	0	
Pn026	Forward torque limit	%	0~300	250	②
Pn027	Reverse torque limit	%	0~300	250	②
Pn028	Positioning complete detection filter	%	0~500	0	
Pn029	Speed coincidence error	r/min	0~100	10	
Pn030	In position error	Reference unit	0~500	10	
Pn031	Error counter overflow range	256 reference unit	1~32767	1024	
Pn032	JOG speed	r/min	0~3000	500	
Pn033	reserved	—	0	0	
Pn034	reserved	—	0	0	
Pn035	reserved	—	0	0	
Pn036	reserved	—	0	0	
Pn037	reserved	—	0	0	
Pn038	Automatic gain adjustment: [0] without automatic gain adjustment [1]after inertia detection, gain is adjusted automatically	—	0~1	0	
Pn039	P/PI Switching Terms [0] setting torque [1] error pulse [2] acceleration [3] motor speed [4] disable mode switch function	—	0~4	0	
Pn040	P/PI switching threshold	—	0~5000	200	
Pn041	Control mode selection [0] Position control (pulse train reference) [1] position contact control (internal position reference) [2]Speed control (contact reference)	—	0~2	0	①
Pn042	Reserved	—	0	0	
Pn043	Waiting time for Servo ON	ms	20~2000	200	
Pn044	Basic waiting procedure	ms	0~5000	10	
Pn045	Waiting speed for brake signal	r/min	10~500	100	

Para. No.	Name and Meaning	Unit	Setting range	Factory setting	Remarks
Pn046	Waiting time for brake signal	ms	10~1000	500	
Pn047	Position error pulse overflow alarm output [0] disable [1] enable	—	0~1	0	
Pn048	Run speed of programmed speed	r/min	-6000~600 0	500	
Pn049	1CN-2output signal selection	—	0~3	0	
Pn050	1CN-3output signal selection	—	0~3	1	
Pn051	1CN two input signal selection	—	0~3	0	
Pn052	Reserved	—	0~32	0	
Pn053	Input I/O signal filter time	ms	0~10000	100	
Pn054	Inverts input signal	—	0~15	0	
Pn055	Inverts output signal	—	0~7	0	
Pn056	2 nd electronic gear numerator	—	1~32767	1	
Pn057	Dynamic electronic gear enable	—	0~1	0	①
Pn058	reserved	—	0	0	
Pn059	RS232 COM input IO contact control	—	0~15	0	
Pn060	RS232 COM address	—	1~254	1	
Pn061	RS232 COM baudrate 0: 4800bit/s 1: 9600bit/s 2: 19200bit/s	bit/s	0~2	1	
Pn062	RS232 COM protocol 0: 7, N, 2 (Modbus, ASCII) 1: 7, E, 1 (Modbus, ASCII) 2: 7, O, 1 (Modbus, ASCII) 3: 8, N, 2 (Modbus, ASCII) 4: 8, E, 1 (Modbus, ASCII) 5: 8, O, 1 (Modbus, ASCII) 6: 8, N, 2 (Modbus, RTU) 7: 8, E, 1 (Modbus, RTU) 8: 8, O, 1 (Modbus, RTU)	—	0~8	5	
Pn063	CAN COM address	—	1~127	1	
Pn064	CAN COM baudrate 0: 50K 1: 100K 2: 125K 3: 250K 4: 500K 5: 1M	Kbit/s	0~5	2	

Para. No.	Name and Meaning	Unit	Setting range	Factory setting	Remarks
Pn065	CAN COM selection [0]disable [1]enable	—	0~1	0	
Pn066	Reserved	—	0	0	
Pn067	Reserved	—	0	0	
Pn068	Select cycle run [0]multi-point cycle run [1]multi-point single run	—	0~1	0	
Pn069	Enable/disable P-CON signal as step chang signal [0] Enable delay step change [1] use P-CON signal as step changing signal	—	0~1	0	
Pn070	Programming method [0]incremental [1]absolute	—	0~1	0	
Pn071	Origin searching method Z Y X Z=0 : turn off origin search function Z=1: Power on, after the 1 st S-ON, start origin search function automatically. Z=2: start origin search function automatically everytime after S-ON. Y=0: Search Pulse C after origin search is done Y=1: don't search Pulse C after origin search is done X=0: forward run origin search ZPS as origin X=1: reverse run origin search ZPS as origin	—	0~211	0	
Pn072	Start point of program	—	0~7	0	
Pn073	End point of program	—	0~7	1	
Pn074	Speed 1 when searching reference point (hit STROKE /travel distance switch)	r/min	0~3000	1000	
Pn075	Speed 3 when searching reference point (away from STRKE/travel distance switch)	r/min	0~300	5	

Para. No.	Name and Meaning	Unit	Setting range	Factory setting	Remarks
Pn076	reserved	—	0~300	0	
Pn077	Cycle number of origin search offset	10 ⁴ reference pulse	9999	0	
Pn078	Pulse number of origin search offset	1 pulse	9999	0	
Pn079	Reserved	—	0	0	
Pn080	moving distance 0 revolutions	10 ⁴ reference pulse	-32767~32767	1	
Pn081	moving distance 0	1 reference pulse	-9999~9999	0	
Pn082	moving distance 1 revolution	10 ⁴ reference pulse	-32767~32767	2	
Pn083	moving distance 1 low	1 reference pulse	-9999~9999	0	
Pn084	moving distance 2 revolutions	10 ⁴ reference pulse	-32767~32767	3	
Pn085	moving distance 2 low	1 reference pulse	-9999~9999	0	
Pn086	moving distance 3 revolutions	10 ⁴ reference pulse	-32767~32767	4	
Pn087	moving distance 3 low	1 reference pulse	-9999~9999	0	
Pn088	moving distance 4 revolutions	10 ⁴ reference pulse	-32767~32767	5	
Pn089	moving distance 4 low	1 reference pulse	-9999~9999	0	
Pn090	moving distance 5 revolutions	10 ⁴ reference pulse	-32767~32767	6	
Pn091	moving distance 5 low	1 reference pulse	-9999~9999	0	

Para. No.	Name and Meaning	Unit	Setting range	Factory setting	Remarks
Pn092	moving distance 6 revolutions	10 ⁴ reference pulse	-32767~32767	7	
Pn093	moving distance 6 low	1 reference pulse	-9999~9999	0	
Pn094	moving distance 7 revolutions	10 ⁴ reference pulse	-32767~32767	8	
Pn095	moving distance 7 low	1 reference pulse	-9999~9999	0	
Pn096	moving distance 0 speed	r/min	0~3000	500	
Pn097	moving distance 1 speed	r/min	0~3000	500	
Pn098	moving distance 2 speed	r/min	0~3000	500	
Pn099	moving distance 3 speed	r/min	0~3000	500	
Pn100	moving distance 4 speed	r/min	0~3000	500	
Pn101	moving distance 5 speed	r/min	0~3000	500	
Pn102	moving distance 6 speed	r/min	0~3000	500	
Pn103	moving distance 7 speed	r/min	0~3000	500	
Pn104	moving distance 0 first(1st) acceleration/deceleration time constant	ms	0~32767	0	
Pn105	moving distance 1 first(1st) acceleration/deceleration time constant	ms	0~32767	0	
Pn106	moving distance 2 first(1st) acceleration/deceleration time constant	ms	0~32767	0	
Pn107	moving distance 3 first(1st) acceleration/deceleration time constant	ms	0~32767	0	
Pn108	moving distance 4 first(1st) acceleration/deceleration time constant	ms	0~32767	0	
Pn109	moving distance 5 first(1st) acceleration/deceleration time constant	ms	0~32767	0	
Pn110	moving distance 6 first(1st) acceleration/deceleration time constant	ms	0~32767	0	
Pn111	moving distance 7 first(1st) acceleration/deceleration time constant	ms	0~32767	0	

Para. No.	Name and Meaning	Unit	Setting range	Factory setting	Remarks
Pn112	moving distance 0stop time	50ms	0~32767	10	
Pn113	moving distance 1stop time	50ms	0~32767	10	
Pn114	moving distance 2stop time	50ms	0~32767	10	
Pn115	moving distance 3stop time	50ms	0~32767	10	
Pn116	moving distance 4stop time	50ms	0~32767	10	
Pn117	moving distance 5stop time	50ms	0~32767	10	
Pn118	moving distance 6stop time	50ms	0~32767	10	
Pn119	moving distance 7stop time	50ms	0~32767	10	
Pn120	Current feed forward compensation	—	0~4096	0	②

⚠ Note:

① After changing the setting, always turn the power OFF, then Power ON again. This makes the new setting valid.

② The parameter may vary for motors of different models.

Appendix B

Alarm list

Alarm display on digital operator	Alarm output	Alarm Name	Meaning
A. 01	×	Parameter breakdown	Checksum results of parameters are abnormal.
A. 02	×	Current detection error	Internal detection circuit problem
A. 03 *	×	Overspeed	Rotation speed of the motor has exceeded 1.1 times of maximum speed
A. 04 *	×	Overload	The motor was running for several seconds to several tens of seconds under a torque largely exceeding ratings
A. 05	×	Position error counter overflows	Internal position error counter has exceeded the value
A. 06	×	Position error pulse overflows	Position error pulse has exceeded the value set in parameter Pn-031.
A. 09	×	Pulse loss of Encoder C	PC is disconnected or have interference
A. 10	×	Encoder disconnected	At least one of PA, PB, PC, PU, PV or PW is disconnected
A. 11	×	Encoder UVW code violation	Encoder UVW code violation
A. 12	×	Power module error	Power module failure
A. 13 *	×	overheat	Power module overheat
A. 14 *	×	Voltage error	Overvoltage or undervoltage of main circuit
A. 15 *	×	Frequency error of input pulse	Pulse frequency input is too high, has exceeded the allowance
A. 16	×	Parameter error	Parameter saved in external storage has errors
A. 17	×	I/O data error	I/O data error, such as ALM, BRK, COIN, Relay, LED lamps, etc. errors

A. 21 *	×	Power loss error	A power interruption exceeding one cycle occurred in AC power supply
A. 25	×	Watchdog reset	System reset by watchdog
A. 99	○	Not an error	Normal operation status

- : Photo-coupler is ON(ON)
 ×: Photo-coupler is OFF (OFF)
 *: Alarm can be deleted.