



Operating Instructions

VLT[®] Soft Starter - MCD500

Contents

1 Safety	5
1.1 Safety	5
2 Introduction	6
2.1.1 Feature List	6
2.1.2 Type Code	7
3 Installation	8
3.1 Mechanical Installation	8
3.2 Dimensions and Weights	9
4 Electrical Installation	10
4.1.1 Control Wiring	10
4.1.2 Control Terminals	10
4.1.3 Remote Inputs	11
4.1.4 Serial Communication	11
4.1.5 Earth Terminal	11
4.1.6 Power Terminations	12
4.1.7 Motor Connection	13
4.2 In-Line Installation	13
4.2.1 In-line Installation, Internally Bypassed	13
4.2.2 In-line Installation, Non-bypassed	13
4.2.3 In-line Installation, Externally Bypassed	14
4.3 Inside Delta Installation	14
4.3.1 Inside Delta Installation, Internally Bypassed	15
4.3.2 Inside Delta Installation, Non-bypassed	15
4.3.3 Inside Delta Installation, Externally Bypassed	16
4.4 Current Ratings	16
4.4.1 In-line Connection (Bypassed)	17
4.4.2 AC-53 Rating for Bypassed Operation	17
4.4.3 In-line Connection (Non-bypassed/Continuous)	18
4.4.4 AC-53 Rating for Continuous Operation	18
4.4.5 Inside Delta Connection (Bypassed)	19
4.4.6 AC-53 Rating for Bypassed Operation	19
4.4.7 Inside Delta Connection (Non-bypassed/Continuous)	20
4.4.8 AC-53 Rating for Continuous Operation	20
4.5 Minimum and Maximum Current Settings	21
4.6 Bypass Contactor	21
4.7 Main Contactor	21
4.8 Circuit Breaker	21

4.9 Power Factor Correction	21
4.10 Fuses	22
4.10.2 Bussman Fuses - Square Body (170M)	23
4.10.3 Bussman Fuses - British Style (BS88)	23
4.10.4 Ferraz Fuses - HSJ	24
4.10.5 Ferraz Fuses - North American Style (PSC 690)	25
4.10.6 UL Tested Fuses - Short Circuit Ratings	26
4.11 Schematic Diagrams	27
4.11.1 Internally Bypassed Models	27
4.11.2 Non-bypassed Models	28
5 Application Examples	29
5.1 Motor Overload Protection	29
5.2 AAC Adaptive Acceleration Control	29
5.3 Starting Modes	30
5.3.1 Constant Current	30
5.3.2 Current Ramp	30
5.3.3 AAC Adaptive Acceleration Control	30
5.3.4 Kickstart	31
5.4 Stopping Modes	31
5.4.1 Coast to Stop	31
5.4.2 TVR Soft Stop	31
5.4.3 AAC Adaptive Acceleration Control	31
5.4.4 Brake	32
5.5 Jog Operation	32
5.6 Inside Delta Operation	33
5.7 Typical Start Currents	33
5.8 Installation with Main Contactor	35
5.9 Installation with Bypass Contactor	36
5.10 Emergency Run Operation	37
5.11 Auxiliary Trip Circuit	38
5.12 Soft Braking	39
5.13 Two Speed Motor	40
6 Operation	42
6.1 Operation and LCP	42
6.1.1 Operating Modes	42
6.2 Control Methods	43
6.3 Local Control Buttons	43
6.4 Displays	44
6.4.1 Temperature Monitoring Screen (S1)	44

6.4.2 Programmable Screen (S2)	44
6.4.3 Average Current (S3)	44
6.4.4 Current Monitoring Screen (S4)	44
6.4.5 Frequency Monitoring Screen (S5)	44
6.4.6 Motor Power Screen (S6)	44
6.4.7 Last Start Information (S7)	44
6.4.8 Date and Time (S8)	45
6.4.9 SCR Conduction Bargraph	45
6.4.10 Performance Graphs	45
7 Programming	46
7.1 Access Control	46
7.2 Quick Menu	47
7.2.1 Quick Setup	47
7.2.2 Application Setups	48
7.2.3 Loggings	49
7.3 Main Menu	49
7.3.1 Parameters	49
7.3.2 Parameter Shortcut	49
7.3.3 Parameter List	50
7.4 Primary Motor Settings	51
7.4.1 Brake	52
7.5 Protection	52
7.5.1 Current Imbalance	52
7.5.2 Undercurrent	52
7.5.3 Instantaneous Overcurrent	53
7.5.4 Frequency Trip	53
7.6 Inputs	53
7.7 Outputs	55
7.7.1 Relay A Delays	55
7.7.2 Relays B and C	55
7.7.3 Low Current Flag and High Current Flag	55
7.7.4 Motor Temperature Flag	56
7.7.5 Analog Output A	56
7.8 Start/Stop Timers	56
7.9 Auto-Reset	57
7.9.1 Auto-Reset Delay	57
7.10 Secondary Motor Set	57
7.11 Display	59
7.11.1 User Programmable Screen	59
7.11.2 Performance Graphs	60

7.12 Restricted Parameters	60
7.13 Protection Action	61
7.14 Factory Parameters	61
8 Tools	62
8.1 Set Date and Time	62
8.2 Load/Save Settings	62
8.3 Reset Thermal Model	62
8.4 Protection Simulation	62
8.5 Output Signal Simulation	63
8.6 Digital I/O State	63
8.7 Temp Sensors State	63
8.8 Alarm Log	63
8.8.1 Trip Log	63
8.8.2 Event Log	64
8.8.3 Counters	64
9 Troubleshooting	65
9.1 Trip Messages	65
9.2 General Faults	68
10 Specifications	70
10.1 Accessories	71
10.1.1 Communication Modules	71
10.1.2 PC Software	72
10.1.3 Finger Guard Kit	72
11 Bus Bar Adjustment Procedure (MCD5-0360C - MCD5-1600C)	73

1 Safety

1.1 Safety

When reading this manual you will come across different symbols that require special attention. The symbols used are the following:

NOTE

Indicates something to be noted by the reader

CAUTION

Indicates a general warning

WARNING

Indicates a high voltage warning

The examples and diagrams in this manual are included solely for illustrative purposes. The information contained in this manual is subject to change at any time and without prior notice. In no event will responsibility or liability be accepted for direct, indirect or consequential damages resulting from the use or application of this equipment.

WARNING

WARNING - ELECTRICAL SHOCK HAZARD

MCD 500 soft starters contain dangerous voltages when connected to mains voltage. Only a competent electrician should carry out the electrical installation. Improper installation of the motor or the soft starter may cause equipment failure, serious injury or death. Follow this manual and local electrical safety codes.

WARNING

Disconnect the soft starter from mains voltage before carrying out repair work.

It is the responsibility of the user or person installing the soft starter to provide proper grounding and branch circuit protection according to local electrical safety codes.

Do not connect power factor correction capacitors to the output of MCD 500 soft starters. If static power factor correction is employed, it must be connected to the supply side of the soft starter.

In Auto On mode, the motor can be stopped using digital or bus commands while the soft starter is connected to mains.

CAUTION

These stop functions are not sufficient to avoid unintended start.

A motor that has been stopped may start if faults occur in the electronics of the soft starter, or a temporary fault in the supply mains or the motor connection ceases.

CAUTION

Use the auto-start feature with caution. Read all the notes related to auto-start before operation.

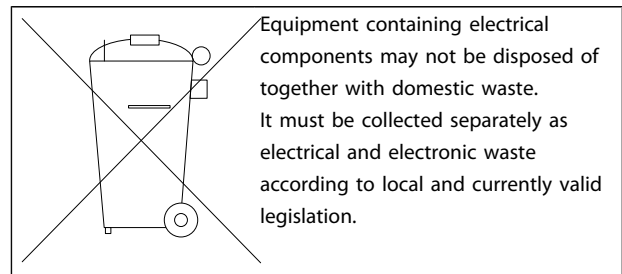

2 Introduction

The MCD 500 is an advanced digital soft start solution for motors from 7 kW to 800 kW. MCD 500 soft starters provide a complete range of motor and system protection features and have been designed for reliable performance in the most demanding installation situations.

2.1.1 Feature List

Models for all connection requirements

- 21 A to 1600 A (in-line connection)
- In-line or inside delta connection
- Internally bypassed up to 215 A
- Mains voltage: 200 - 525 VAC or 380 - 690 VAC
- Control voltage: 24 VAC/VDC, 110 - 120 VAC or 220 - 240 VAC

User-friendly LCP

- Loggings
- Real-time graphs
- SCR conduction bar graph

Tools

- Application setups
- Date and time stamped event log with 99 entries
- 8 most recent trips
- Counters
- Protection simulation
- Output signal simulation

Inputs and Outputs

- Local or remote control input options (3 x fixed 1 x programmable)
- Relay outputs (3 x programmable)
- Analog programmable output
- 24 VDC 200 mA supply output

Start and run modes

- AAC - Adaptive Acceleration Control
- Constant current
- Current ramp
- Kickstart
- Jog
- Emergency run operation

Stop modes

- AAC - Adaptive Acceleration Control
- Timed voltage ramp soft stop

- DC brake
- Soft brake
- Emergency stop

Other features

- Auto start/stop timer
- Second order thermal model
- Battery backup of clock and thermal model
- Optional DeviceNet, Modbus or Profibus communication modules

Comprehensive protection

- Wiring/Connection/Supply
 - Motor connection
 - Phase sequence
 - Power loss
 - Individual phase loss
 - Mains frequency
- Current
 - Excess start time
 - Current imbalance
 - Undercurrent
 - Instantaneous overcurrent
- Thermal
 - Motor thermistor
 - Motor overload
 - Bypass relay overload
 - Heatsink temperature
- Communication
 - Network comms
 - Starter comms
- External
 - Input trip
- Starter
 - Individual shorted SCR
 - Battery/Clock

2.1.2 Type Code

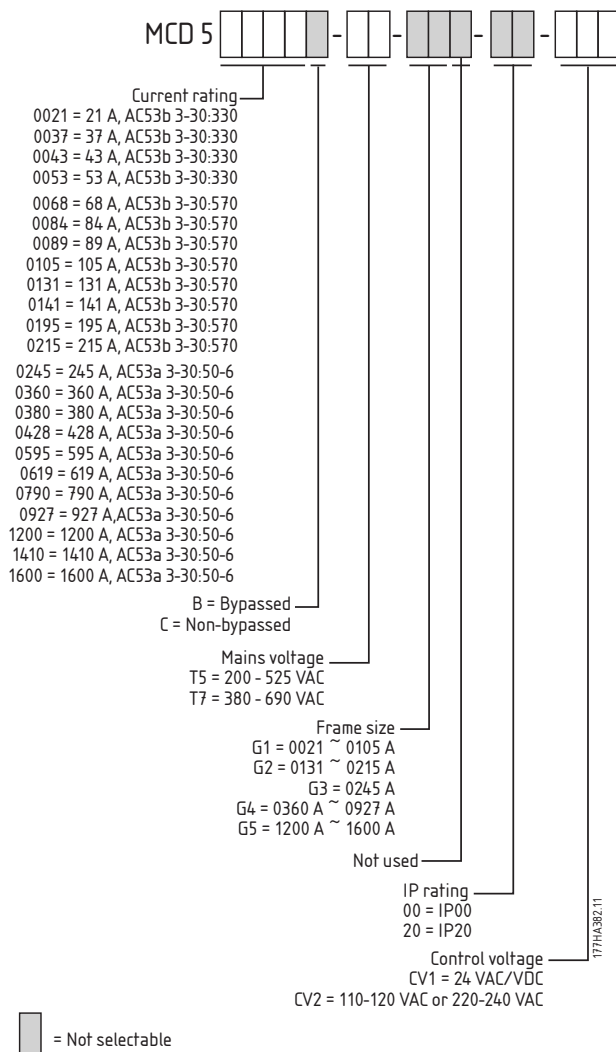

3 Installation

3

3.1 Mechanical Installation

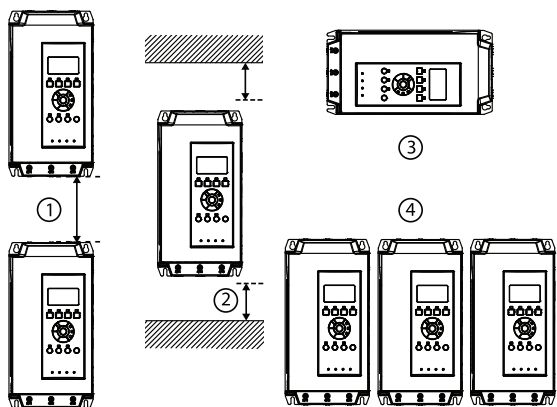

1	MCD5-0021B - MCD5-0245C: Allow 100 mm (3.94 inches) between soft starters. MCD5-0360C - MCD5-1600C: Allow 200 mm (7.88 inches) between soft starters.
2	MCD5-0021B - MCD5-0215B: Allow 50 mm (1.97 inches) between the soft starter and solid surfaces. MCD5-0245C: Allow 100 mm (3.94 inches) between the soft starter and solid surfaces. MCD5-0360C - MCD5-1600C: Allow 200 mm (7.88 inches) between the soft starter and solid surfaces.
3	The soft starter may be mounted on its side. Derate the soft starter's rated current by 15%.
4	Soft starters may be mounted side by side with clearance of 50 mm (1.97 inches) on both sides.

3.2 Dimensions and Weights

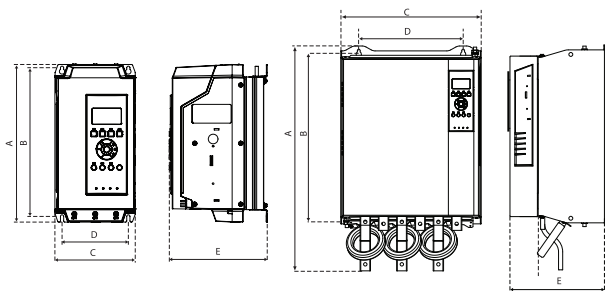

3

Model	A mm (inches)	B mm (inches)	C mm (inches)	D mm (inches)	E mm (inches)	Weight kg (lbs)
MCD5-0021B	295 (11.6)	278 (10.9)	150 (5.9)	124 (4.9)	183 (7.2)	4.2 (9.3)
MCD5-0037B					213 (8.14)	4.5 (9.9)
MCD5-0043B						
MCD5-0053B						
MCD5-0068B						
MCD5-0084B					250 (9.8)	4.9 (10.8)
MCD5-0089B						
MCD5-0105B						
MCD5-0131B	438 (17.2)	380 (15.0)	275 (10.8)	248 (9.8)	279 (11.0)	23.9 (52.7)
MCD5-0141B						
MCD5-0195B						
MCD5-0215B						
MCD5-0245C	689 (27.1)	522 (20.5)	430 (16.9)	320 (12.6)	300.2 (11.8)	35 (77.2)
MCD5-0360C						45 (99.2)
MCD5-0380C						
MCD5-0428C						
MCD5-0595C						
MCD5-0619C						
MCD5-0790C	856 (33.7)	727 (28.6)	585 (23.0)	500 (19.7)	364 (14.3)	120 (264.6)
MCD5-0927C						
MCD5-1200C						
MCD5-1410C						
MCD5-1600C						

4 Electrical Installation

4.1 Electrical Installation

4.1.1 Control Wiring

4

The soft starter can be controlled in three ways:

- using the buttons on the LCP
- via remote inputs
- via a serial communication link

The MCD 500 will always respond to a local start or stop command (via the **Hand On** and **Off** buttons on the LCP). Pressing the **Auto On** button selects remote control (the MCD 500 will accept commands from the remote inputs). In remote mode, the Auto On LED will be on. In local mode, the Hand On LED will be on if the MCD 500 is starting or running and the Off LED will be on if the MCD 500 is stopped or stopping.

4.1.2 Control Terminals

Control terminations use 2.5 mm² plug-in terminal blocks. Different models require control voltage to different terminals:

CV1 (24 VAC/VDC)	A5, A6
CV2 (110 - 120 VAC)	A5, A6
CV2 (220 - 240 VAC)	A4, A6

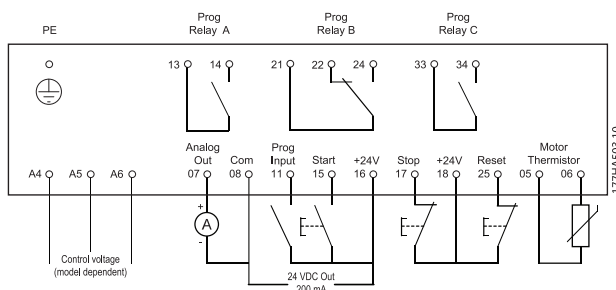

NOTE

If you are not using a thermistor, do not short terminals 05, 06.

All control terminals and relay terminals comply with SELV (Protective Extra Low Voltage). This protection does not apply to grounded Delta leg above 400V.

To maintain SELV, all connections made to the control terminals must be PELV (eg. thermistor must be reinforced/ double insulated from motor).

NOTE

SELV offers protection by way of extra low voltage. Protection against electric shock is ensured when the electrical supply is of the SELV type and the installation is made as described in local/national regulations on SELV supplies.

NOTE

Galvanic (ensured) isolation is obtained by fulfilling requirements for higher isolation and by providing the relevant creepages/clearance distances. These requirements are described in the IEC61140 standard. The components that make up the electrical isolation also comply with the requirements for higher isolation and the relevant test as described in IEC61140.

4.1.3 Remote Inputs

The MCD 500 has three fixed inputs for remote control. These inputs should be controlled by contacts rated for low voltage, low current operation (gold flash or similar).

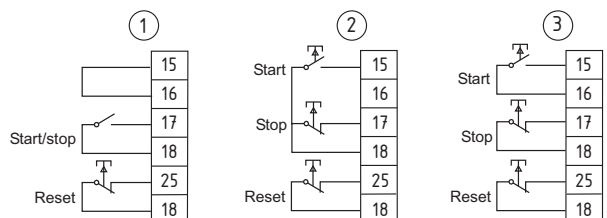

1	Two-wire control
2	Three-wire control
3	Four-wire control

The reset input can be normally open or normally closed. Use par. 3-8 to select the configuration.

CAUTION

Do not apply voltage to the control input terminals. These are active 24 VDC inputs and must be controlled with potential free contacts.
Cables to the control inputs must be segregated from mains voltage and motor cabling

4.1.4 Serial Communication

Serial communication is always enabled in local control mode, and can be enabled or disabled in remote control mode (see par. 3-2).

4.1.5 Earth Terminal

Earth terminals are located at the back of the soft starter.

- MCD5-0021B - MCD5-0105B have one terminal, on the input side.
- MCD5-0131B - MCD5-1600C have two terminals, one on the input side and one on the output side.

4.1.6 Power Terminations

Use only copper stranded or solid conductors, rated for 75° C.

NOTE

Some units are aluminium bus bars. When connecting power terminations, we recommend cleaning the surface contact area thoroughly (using an emery or stainless steel brush) and using an appropriate jointing compound to prevent corrosion.

4

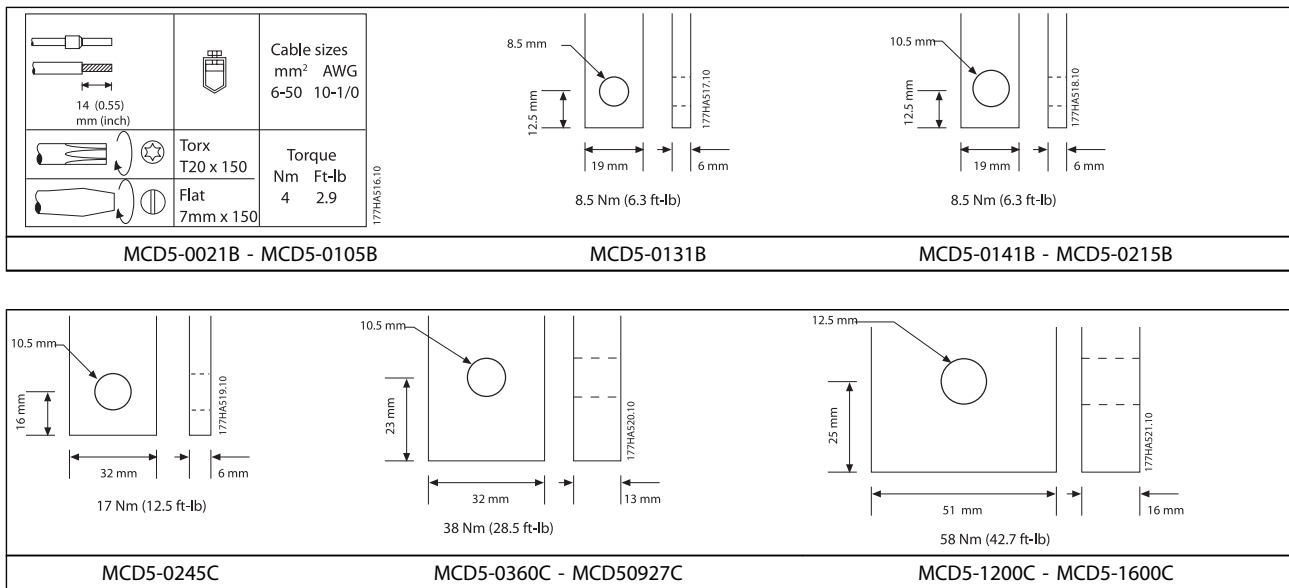

The bus bars on models MCD5-0360C - MCD5-1600C can be adjusted for top or bottom input and output as required. For step-by-step instructions on adjusting the bus bars, refer to the supplied insert.

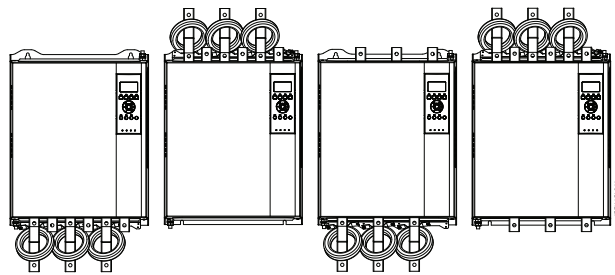

I/O	Input/Output
I	Input
O	Output

4.1.7 Motor Connection

MCD 500 soft starters can be connected to the motor in-line or inside delta (also called three-wire and six-wire connection). The MCD 500 will automatically detect the motor connection and perform the necessary calculations internally, so it is only necessary to program the motor full load current (par. 1-1).

NOTE

For personnel safety, the power terminals on models up to MCD5-0105B are protected by snap-off tabs. When using large cables, it may be necessary to break off these tabs. Models which are internally bypassed do not require an external bypass contactor.

4.2 In-Line Installation

4.2.1 In-line Installation, Internally Bypassed

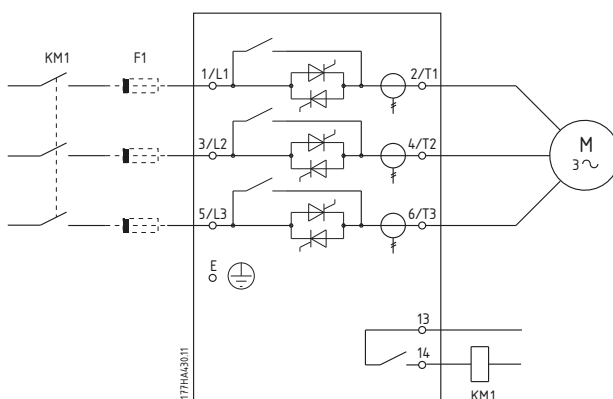

KM1	Main contactor (optional)
F1	Fuses (optional)

4.2.2 In-line Installation, Non-bypassed

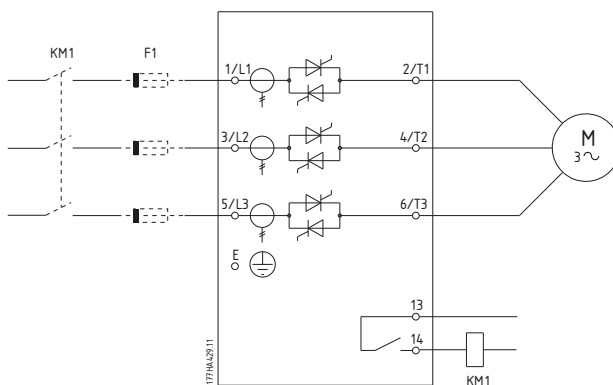

KM1	Main contactor (optional)
F1	Fuses (optional)

4.2.3 In-line Installation, Externally Bypassed

Non-bypassed models have dedicated bypass terminals, which allow the soft starter to continue providing protection and monitoring functions even when bypassed via external contactor. The bypass contactor must be connected to the bypass terminals and controlled by a programmable output configured to Run (see par. 4.1 - 4.9).

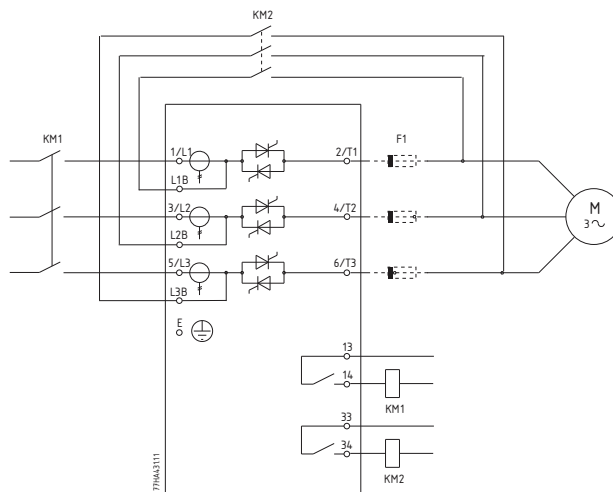

KM1	Main contactor
KM2	Bypass contactor
F1	Fuses (optional)

NOTE

The bypass terminals on MCD5-0245C are T1B, T2B, T3B. The bypass terminals on MCD5-0360C ~ MCD5-1600C are L1B, L2B, L3B.

The fuses can be installed on the input side if required.

4.3 Inside Delta Installation

CAUTION

When connecting the MCD 500 in inside delta configuration, always install a main contactor or shunt trip circuit breaker.

NOTE

When connecting in inside delta, enter the motor full load current (FLC) for par. 2-1 *Phase Sequence*. MCD 500 software calculates inside delta currents from this. Par. 15-7 *Motor Connection* is set to *Auto detect* as default and can be set to force the soft starter inside delta or in-line.

4.3.1 Inside Delta Installation, Internally Bypassed

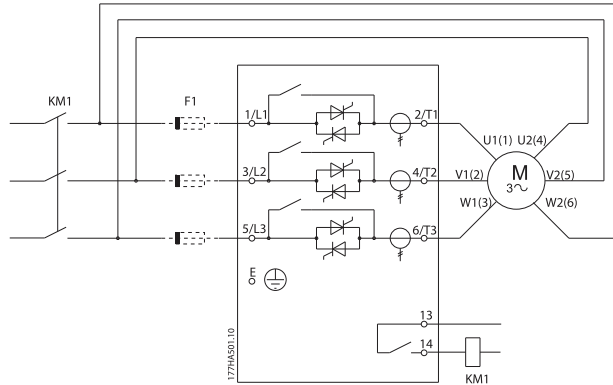

KM1	Main contactor
F1	Fuses (optional)

4.3.2 Inside Delta Installation, Non-bypassed

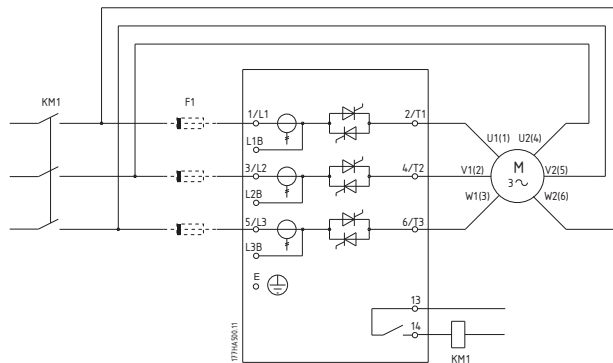

KM1	Main contactor
F1	Fuses (optional)

4.3.3 Inside Delta Installation, Externally Bypassed

Non-bypassed models have dedicated bypass terminals, which allow the MCD 500 to continue providing protection and monitoring functions even when bypassed via an external bypass contactor. The bypass relay must be connected to the bypass terminals and controlled by a programmable output configured to Run (see par. 4-1 - 4-9).

4

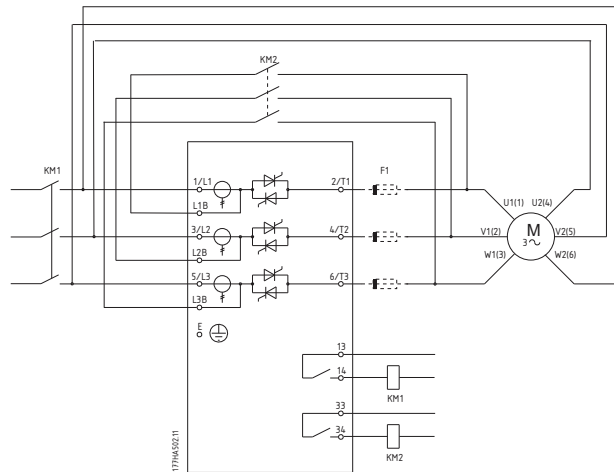

KM1	Main contactor
KM2	Bypass contactor
F1	Fuses (optional)

NOTE

The bypass terminals on MCD5-0245C are T1B, T2B, T3B. The bypass terminals on MCD5-0360C - MCD5-1600C are L1B, L2B, L3B.

The fuses can be installed on the input side if required.

4.4 Current Ratings

Contact your local supplier for ratings under operating conditions not covered by these ratings charts.

All ratings are calculated at altitude of 1000 metres and ambient temperature of 40° C.

4.4.1 In-line Connection (Bypassed)

NOTE

Models MCD5-0021B - MCD5-0215B are internally bypassed.

Models MCD5-0245C - MCD5-1600C require an external bypass contactor.

	AC-53b 3-30:330	AC-53b 4-20:340	AC-53b 4.5-30:330
MCD5-0021B	21 A	17 A	15 A
MCD5-0037B	37 A	31 A	26 A
MCD5-0043B	43 A	37 A	30 A
MCD5-0053B	53 A	46 A	37 A
	AC-53b 3-30:570	AC-53b 4-20:580	AC-53b 4.5-30:570
MCD5-0068B	68 A	55 A	47 A
MCD5-0084B	84 A	69 A	58 A
MCD5-0089B	89 A	74 A	61 A
MCD5-0105B	105 A	95 A	78 A
MCD5-0131B	131 A	106 A	90 A
MCD5-0141B	141 A	121 A	97 A
MCD5-0195B	195 A	160 A	134 A
MCD5-0215B	215 A	178 A	148 A
MCD5-0245C	255 A	201 A	176 A
MCD5-0360C	360 A	310 A	263 A
MCD5-0380C	380 A	359 A	299 A
MCD5-0428C	430 A	368 A	309 A
MCD5-0595C	620 A	540 A	434 A
MCD5-0619C	650 A	561 A	455 A
MCD5-0790C	790 A	714 A	579 A
MCD5-0927C	930 A	829 A	661 A
MCD5-1200C	1200 A	1200 A	1071 A
MCD5-1410C	1410 A	1319 A	1114 A
MCD5-1600C	1600 A	1600 A	1353 A

4

4.4.2 AC-53 Rating for Bypassed Operation

$141 \text{ A} : \text{AC-53b} : 4.5-30 : 570$
 Starter Current Rating Start Current (multiple of FLC) Start Time (seconds) Off Time (seconds)

177HA281.11

All ratings are calculated at altitude of 1000 metres and ambient temperature of 40° C.

4.4.3 In-line Connection (Non-bypassed/Continuous)

	AC-53a 3-30:50-6	AC-53a 4-20:50-6	AC-53a 4.5-30:50-6
MCD5-0245C	245 A	195 A	171 A
MCD5-0360C	360 A	303 A	259 A
MCD5-0380C	380 A	348 A	292 A
MCD5-0428C	428 A	355 A	300 A
MCD5-0595C	595 A	515 A	419 A
MCD5-0619C	619 A	532 A	437 A
MCD5-0790C	790 A	694 A	567 A
MCD5-0927C	927 A	800 A	644 A
MCD5-1200C	1200 A	1135 A	983 A
MCD5-1410C	1410 A	1187 A	1023 A
MCD5-1600C	1600 A	1433 A	1227 A

4

4.4.4 AC-53 Rating for Continuous Operation

245 A: AC-53a: 4.5-30 : 70-10
 Starter Current Rating Start Time (seconds)
 Start Current (multiple of FLC) On-load Duty Cycle Starts Per Hour

177HA280.11

All ratings are calculated at altitude of 1000 metres and ambient temperature of 40° C.

4.4.5 Inside Delta Connection (Bypassed)

NOTE

Models MCD5-0021B ~ MCD5-0215B are internally bypassed.

Models MCD5-0245C ~ MCD5-1600C require an external bypass contactor.

	AC-53b 3-30:330	AC-53b 4-20:340	AC-53b 4.5-30:330
MCD5-0021B	32 A	26 A	22 A
MCD5-0037B	56 A	47 A	39 A
MCD5-0043B	65 A	56 A	45 A
MCD5-0053B	80 A	69 A	55 A
	AC-53b 3-30:570	AC-53b 4-20:580	AC-53b 4.5-30:570
MCD5-0068B	102 A	83 A	71 A
MCD5-0084B	126 A	104 A	87 A
MCD5-0089B	134 A	112 A	92 A
MCD5-0105B	158 A	143 A	117 A
MCD5-0131B	197 A	159 A	136 A
MCD5-0141B	212 A	181 A	146 A
MCD5-0195B	293 A	241 A	201 A
MCD5-0215B	323 A	268 A	223 A
MCD5-0245C	383 A	302 A	264 A
MCD5-0360C	540 A	465 A	395 A
MCD5-0380C	570 A	539 A	449 A
MCD5-0428C	645 A	552 A	463 A
MCD5-0595C	930 A	810 A	651 A
MCD5-0619C	975 A	842 A	683 A
MCD5-0790C	1185 A	1072 A	869 A
MCD5-0927C	1395 A	1244 A	992 A
MCD5-1200C	1800 A	1800 A	1607 A
MCD5-1410C	2115 A	1979 A	1671 A
MCD5-1600C	2400 A	2400 A	2030 A

4.4.6 AC-53 Rating for Bypassed Operation

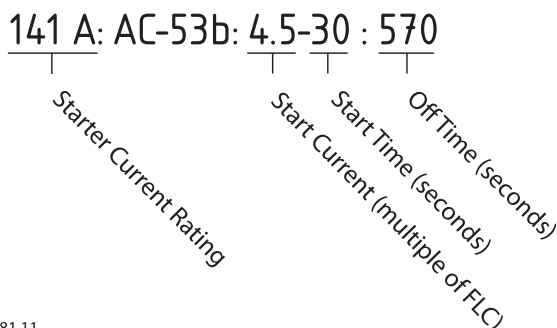

177HA281.11

All ratings are calculated at altitude of 1000 metres and ambient temperature of 40° C.

4.4.7 Inside Delta Connection (Non-bypassed/Continuous)

	AC-53a 3-30:50-6	AC-53a 4-20:50-6	AC-53a 4.5-30:50-6
MCD5-0245C	368 A	293 A	257 A
MCD5-0360C	540 A	455 A	389 A
MCD5-0380C	570 A	522 A	438 A
MCD5-0428C	643 A	533 A	451 A
MCD5-0595C	893 A	773 A	629 A
MCD5-0619C	929 A	798 A	656 A
MCD5-0790C	1185 A	1042 A	851 A
MCD5-0927C	1391 A	1200 A	966 A
MCD5-1200C	1800 A	1702 A	1474 A
MCD5-1410C	2115 A	1780 A	1535 A
MCD5-1600C	2400 A	2149 A	1841 A

4.4.8 AC-53 Rating for Continuous Operation

245 A: AC-53a: 4.5-30 : 70-10
 Starter Current Rating Start Time (seconds)
 Start Current (multiple of FLC) On-load Duty Cycle Starts Per Hour

177HA280.11

All ratings are calculated at altitude of 1000 metres and ambient temperature of 40° C.

4.5 Minimum and Maximum Current Settings

The MCD 500's minimum and maximum full load current settings depend on the model:

Model	In-line Connection		Inside Delta Connection	
	Minimum	Maximum	Minimum	Maximum
MCD5-0021B	5 A	23 A	7 A	34 A
MCD5-0037B	9 A	43 A	13 A	64 A
MCD5-0043B	10 A	50 A	15 A	75 A
MCD5-0053B	11 A	53 A	16 A	79 A
MCD5-0068B	15 A	76 A	23 A	114 A
MCD5-0084B	19 A	97 A	29 A	145 A
MCD5-0089B	20 A	100 A	30 A	150 A
MCD5-0105B	21 A	105 A	32 A	157 A
MCD5-0131B	29 A	145 A	44 A	217 A
MCD5-0141B	34 A	170 A	51 A	255 A
MCD5-0195B	40 A	200 A	60 A	300 A
MCD5-0215B	44 A	220 A	66 A	330 A
MCD5-0245C	51 A	255 A	77 A	382 A
MCD5-0360C	72 A	360 A	108 A	540 A
MCD5-0380C	76 A	380 A	114 A	570 A
MCD5-0428C	86 A	430 A	129 A	645 A
MCD5-0595C	124 A	620 A	186 A	930 A
MCD5-0619C	130 A	650 A	195 A	975 A
MCD5-0790C	158 A	790 A	237 A	1185 A
MCD5-0927C	186 A	930 A	279 A	1395 A
MCD5-1200C	240 A	1200 A	360 A	1800 A
MCD5-1410C	282 A	1410 A	423 A	2115 A
MCD5-1600C	320 A	1600 A	480 A	2400 A

4

4.6 Bypass Contactor

MCD 500 soft starters with model numbers MCD5-0021B - MCD5-0215B are internally bypassed and do not require an external bypass contactor.

MCD 500 soft starters with model numbers MCD5-0245C - MCD5-1600C are not internally bypassed and may be installed with an external bypass contactor. Select a contactor with an AC1 rating greater than or equal to the full load current rating of the connected motor.

4.7 Main Contactor

A main contactor must be installed if the MCD 500 is connected to the motor in inside delta format and is optional for in-line connection. Select a contactor with an AC3 rating greater than or equal to the full load current rating of the connected motor.

4.8 Circuit Breaker

A shunt trip circuit breaker may be used instead of a main contactor to isolate the motor circuit in the event of a soft starter trip. The shunt trip mechanism must be powered from the supply side of the circuit breaker or from a separate control supply.

4.9 Power Factor Correction

If power factor correction is used, a dedicated contactor should be used to switch in the capacitors. Power factor correction capacitors must be connected to the input side of the soft starter.

CAUTION

Power factor correction capacitors must be connected to the input side of the soft starter. Connecting power factor correction capacitors to the output side will damage the soft starter.

4.10 Fuses

4.10.1 Power Supply Fuses

Semiconductor fuses can be used for Type 2 coordination (according to IEC 60947-4-2 standard) and to reduce the risk of damage to SCRs from transient overload currents.

HRC fuses (such as Ferraz AJT fuses) can be used for Type 1 coordination according to IEC 60947-4-2 standard.

NOTE

Adaptive Acceleration Control (AAC) controls the motor's speed profile, within the programmed time limit. This may result in a higher level of current than traditional control methods.

For applications using Adaptive Acceleration Control to soft stop the motor with stop times greater than 30 seconds, motor branch protection should be selected as follows:

- Standard HRC line fuses: Minimum 150% motor full load current
- Motor rated line fuses: Minimum rating 100/150% motor full load current

- Motor control circuit breaker minimum long time setting: 150% motor full load current
- Motor control circuit breaker minimum short time setting: 400% motor full load current for 30 seconds

Fuses recommendations are calculated for 40° C, up to 1000 m.

NOTE

Fuse selection is based on a 400% FLC start for 20 seconds in conjunction with standard published starts per hour, duty cycle, 40° C ambient temperature and up to 1000 m altitude. For installations operating outside these conditions, consult your local supplier.

NOTE

These fuse tables contain recommendations only, always consult your local supplier to confirm the selection for your particular application.

For models marked - there is no suitable fuse.

4.10.2 Bussman Fuses - Square Body (170M)

Model	SCR I ² t (A ² s)	Supply Voltage (≤ 440 VAC)	Supply Voltage (≤ 575 VAC)	Supply Voltage (≤ 690 VAC)
MCD5-0021B	1150	170M1314	170M1314	170M1314
MCD5-0037B	8000	170M1316	170M1316	170M1316
MCD5-0043B	10500	170M1318	170M1318	170M1318
MCD5-0053B	15000	170M1318	170M1318	170M1318
MCD5-0068B	15000	170M1319	170M1319	170M1318
MCD5-0084B	512000	170M1321	170M1321	170M1319
MCD5-0089B	80000	170M1321	170M1321	170M1321
MCD5-0105B	125000	170M1321	170M1321	170M1321
MCD5-0131B	125000	170M1321	170M1321	170M1321
MCD5-0141B	320000	170M2621	170M2621	170M2621
MCD5-0195B	320000	170M2621	170M2621	170M2621
MCD5-0215B	320000	170M2621	170M2621	170M2621
MCD5-0245C	320000	170M2621	170M2621	170M2621
MCD5-0360C	320000	170M6010	170M6010	170M6010
MCD5-0380C	320000	170M6011	170M6011	-
MCD5-0428C	320000	170M6011	170M6011	-
MCD5-0595C	1200000	170M6015	170M6015	170M6014
MCD5-0619C	1200000	170M6015	170M6015	170M6014
MCD5-0790C	2530000	170M6017	170M6017	170M6016
MCD5-0927C	4500000	170M6019	170M6019	170M6019
MCD5-1200C	4500000	170M6021	-	-
MCD5-1410C	6480000	-	-	-
MCD5-1600C	12500000	170M6019*	-	-

* Two parallel connected fuses required per phase.

4.10.3 Bussman Fuses - British Style (BS88)

Model	SCR I ² t (A ² s)	Supply Voltage (< 440 VAC)	Supply Voltage (< 575 VAC)	Supply Voltage (< 690 VAC)
MCD5-0021B	1150	63FE	63FE	63FE
MCD5-0037B	8000	120FEE	120FEE	120FEE
MCD5-0043B	10500	120FEE	120FEE	120FEE
MCD5-0053B	15000	200FEE	200FEE	200FEE
MCD5-0068B	15000	200FEE	200FEE	200FEE
MCD5-0084B	512000	200FEE	200FEE	200FEE
MCD5-0089B	80000	280FM	280FM	280FM
MCD5-0105B	125000	280FM	280FM	280FM
MCD5-0131B	125000	280FM	280FM	280FM
MCD5-0141B	320000	450FMM	450FMM	450FMM
MCD5-0195B	320000	450FMM	450FMM	450FMM
MCD5-0215B	320000	450FMM	450FMM	450FMM
MCD5-0245C	320000	450FMM	450FMM	450FMM
MCD5-0360C	320000	-	-	-
MCD5-0380C	320000	400FMM*	400FMM	400FMM*
MCD5-0428C	320000	-	-	-
MCD5-0595C	1200000	630FMM*	630FMM*	-
MCD5-0619C	1200000	630FMM*	630FMM*	-
MCD5-0790C	2530000	-	-	-
MCD5-0927C	4500000	-	-	-
MCD5-1200C	4500000	-	-	-
MCD5-1410C	6480000	-	-	-
MCD5-1600C	12500000	-	-	-

* Two parallel connected fuses required per phase.

4.10.4 Ferraz Fuses - HSJ

4

Model	SCR I ² t (A ² s)	Supply Voltage (< 440 VAC)	Supply Voltage (< 575 VAC)	Supply Voltage (< 690 VAC)
MCD5-0021B	1150	HSJ40**	HSJ40**	Not suitable
MCD5-0037B	8000	HSJ80**	HSJ80**	
MCD5-0043B	10500	HSJ90**	HSJ90**	
MCD5-0053B	15000	HSJ110**	HSJ110**	
MCD5-0068B	15000	HSJ125**	HSJ125**	
MCD5-0084B	51200	HSJ175	HSJ175**	
MCD5-0089B	80000	HSJ175	HSJ175	
MCD5-0105B	125000	HSJ225	HSJ225	
MCD5-0131B	125000	HSJ250	HSJ250**	
MCD5-0141B	320000	HSJ300	HSJ300	
MCD5-0195B	320000	HSJ350	HSJ350	
MCD5-0215B	320000	HSJ400**	HSJ400**	
MCD5-0245C	320000	HSJ450**	HSJ450**	
MCD5-0360C	320000			
MCD5-0380C	320000			
MCD5-0428C	320000			
MCD5-0595C	1200000			
MCD5-0619C	1200000			
MCD5-0790C	2530000	Not suitable	Not suitable	
MCD5-0927C	4500000			
MCD5-1200C	4500000			
MCD5-1410C	6480000			
MCD5-1600C	12500000			

** Two series connected fuses required per phase,

4.10.5 Ferraz Fuses - North American Style (PSC 690)

Model	SCR I ² t (A ² s)	Supply Voltage < 440 VAC	Supply Voltage < 575 VAC	Supply Voltage < 690 VAC
MCD5-0021B	1150	A070URD30XXX0063	A070URD30XXX0063	-
MCD5-0037B	8000	A070URD30XXX0125	A070URD30XXX0125	A070URD30XXX0125
MCD5-0043B	10500	A070URD30XXX0125	A070URD30XXX0125	A070URD30XXX0125
MCD5-0053B	15000	A070URD30XXX0125	A070URD30XXX0125	A070URD30XXX0125
MCD5-0068B	15000	A070URD30XXX0160	A070URD30XXX0160	A070URD30XXX0160
MCD5-0084B	51200	A070URD30XXX0200	A070URD30XXX0200	A070URD30XXX0200
MCD5-0089B	80000	A070URD30XXX0200	A070URD30XXX0200	A070URD30XXX0200
MCD5-0105B	125000	A070URD30XXX0315	A070URD30XXX0315	A070URD30XXX0315
MCD5-0131B	125000	A070URD30XXX0315	A070URD30XXX0315	A070URD30XXX0315
MCD5-0141B	320000	A070URD30XXX0315	A070URD30XXX0315	A070URD30XXX0315
MCD5-0195B	320000	A070URD30XXX0450	A070URD30XXX0450	A070URD30XXX0450
MCD5-0215B	320000	A070URD30XXX0450	A070URD30XXX0450	A070URD30XXX0450
MCD5-0245C	320000	A070URD30XXX0450	A070URD30XXX0450	A070URD30XXX0450
MCD5-0360C	320000	A070URD33XXX0630	A070URD33XXX0630	A070URD33XXX0630
MCD5-0380C	320000	A070URD33XXX0700	A070URD33XXX0700	-
MCD5-0428C	320000	A070URD33XXX0700	A070URD33XXX0700	-
MCD5-0595C	1200000	A070URD33XXX1000	A070URD33XXX1000	A070URD33XXX1000
MCD5-0619C	1200000	A070URD33XXX1000	A070URD33XXX1000	A070URD33XXX1000
MCD5-0790C	2530000	A070URD33XXX1400	A070URD33XXX1400	A070URD33XXX1400
MCD5-0927C	4500000	A070URD33XXX1400	A070URD33XXX1400	A070URD33XXX1400
MCD5-1200C	4500000	A055URD33XXX2250	-	-
MCD5-1410C	6480000	A055URD33XXX2250	-	-
MCD5-1600C	12500000	-	-	-

XXX = blade type. Refer to Ferraz catalog for details.

4.10.6 UL Tested Fuses - Short Circuit Ratings

4

Model	Nominal Rating (A)	Short Circuit Rating 480V AC (kA)	Short Circuit Rating 600V AC (kA)	Fuse Ferraz	
MCD5-0021B	23	65	10	AJT50	A070URD30XXX0063
MCD5-0037B	43	65	10	AJT50	A070URD30XXX0125
MCD5-0043B	50	65	10	AJT50	A070URD30XXX0125
MCD5-0053B	53	65	10	AJT60	A070URD30XXX0125
MCD5-0068B	76	65	10	AJT80	A070URD30XXX0200
MCD5-0084B	97	65	10	AJT100	A070URD30XXX0200
MCD5-0089B	100	65	10	AJT100	A070URD30XXX0200
MCD5-0105B	105	65	10	AJT125	A070URD30XXX0315
MCD5-0131B	145	65	18	AJT150	A070URD30XXX0315
MCD5-0141B	170	65	18	AJT175	A070URD30XXX0315
MCD5-0195B	200	65	18	AJT200	A070URD30XXX0450
MCD5-0215B	220	65	18	AJT250	A070URD30XXX0450
MCD5-0245C	255	85	85	AJT300	A070URD30XXX0450
MCD5-0360C	360	85	85	AJT400	A070URD33XXX0630
MCD5-0380C	380	85	85	AJT450	A070URD33XXX0700
MCD5-0425B	430	85	85	AJT450	A070URD33XXX0700
MCD5-0595C	620	85	85	A4BQ800	A070URD33XXX1000
MCD5-0619C	650	85	85	A4BQ800	A070URD33XXX1000
MCD5-0790C	790	85	85	A4BQ1200	070URD33XXX1400
MCD5-0927C	930	85	85	A4BQ1200	A070URD33XXX1400
MCD5-1200C	1200	100	100	A4BQ1600	A065URD33XXX1800
MCD5-1410C	1410	100	100	A4BQ2000	A055URD33XXX2250
MCD5-1600C	1600	100	100	A4BQ2500	A055URD33XXX2250

4.11 Schematic Diagrams

4.11.1 Internally Bypassed Models

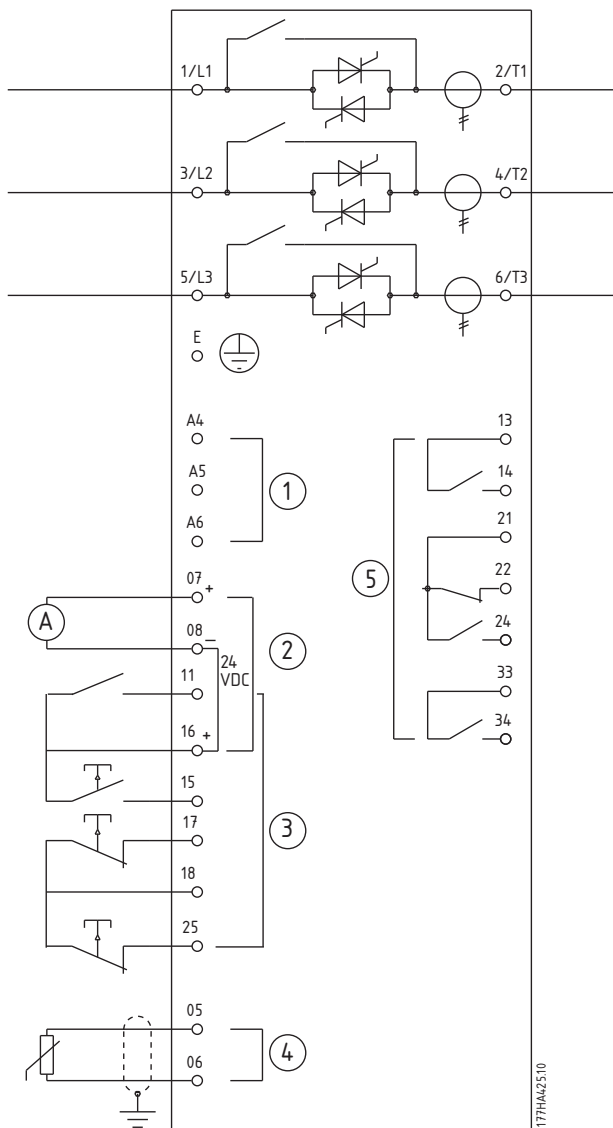

4

1	Control supply (model dependent)
2	Outputs
07, 08	Programmable analog output
16, 08	24 VDC output
3	Remote control inputs
11, 16	Programmable input
15, 16	Start
17, 18	Stop
25, 18	Reset
4	Motor thermistor input (PTC only)
5	Relay outputs
13, 14	Relay output A
21, 22, 24	Relay output B
33, 34	Relay output C

4.11.2 Non-bypassed Models

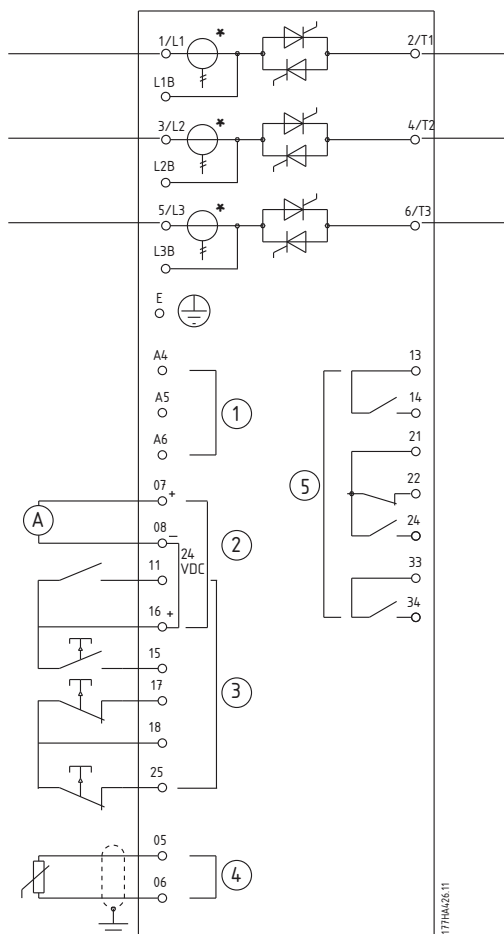

1	Control supply (model dependent)
2	Outputs
07, 08	Programmable analog output
16, 08	24 VDC output
3	Remote control inputs
11, 16	Programmable input
15, 16	Start
17, 18	Stop
25, 18	Reset
4	Motor thermistor input (PTC only)
5	Relay outputs
13, 14	Relay output A
21, 22, 24	Relay output B
33, 34	Relay output C

NOTE

* MCD5-0245C current transformers are located on the output. Bypass terminals are labelled T1B, T2B and T3B.

5 Application Examples

5.1 Motor Overload Protection

The thermal model used for motor overload in the MCD 500 has two components:

- **Motor windings:** These have a low thermal capacity and affects the short term thermal behaviour of the motor. This is where the heat is generated by the current.
- **Motor Body:** This has a large thermal capacity and affects the long term behaviour of the motor. The thermal model includes considerations for the following:
 - Motor current, iron losses, winding resistance losses, motor body and winding thermal capacities, cooling during run and cooling at standstill.
 - The percentage of the rated capacity of the motor. This sets the displayed value for the winding model and is affected by the motor FLC setting amongst others.

NOTE

Par. 1-1 *Motor FLC* should be set to the motor's rated FLC. Do not add the overload rating as this is computed by the MCD500.

The thermal overload protection used in MCD500 has a number of advantages over the thermal relays.

- The effect of fan cooling is accounted for when the motor is running
- The actual full load current and locked rotor time can be used to more accurately tune the model. The thermal characteristics of the windings are treated separately from the rest of the motor (ie. the model recognises that the windings have low thermal mass and high thermal resistance).
- The winding portion of the thermal model responds very rapidly compared with the body portion, meaning the motor can be run closer to its safe maximum operating temperature while still being protected from thermal damage.
- The percentage of motor thermal capacity used during each start is stored in memory. The starter can be configured to automatically determine whether or not the motor has sufficient thermal capacity remaining to successfully complete another start.

- The memory function of the model means that the motor is fully protected in "warm start" situations. The model uses data from the real time clock to account for elapsed cooling time, even if control power has been removed.

The overload protection function provided by this model is compliant with a NEMA 10 curve, but will provide superior protection at low levels of overload due to the separation of the winding thermal model.

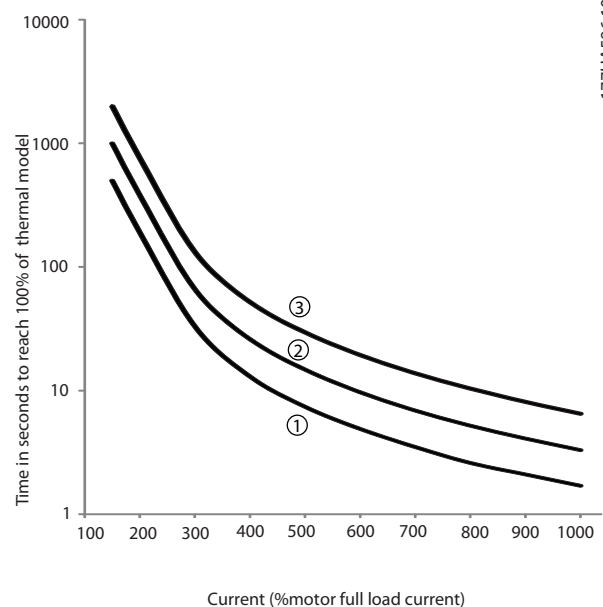

1. $MSTC^1 = 5$
2. $MSTC^1 = 10$
3. $MSTC^1 = 20$

¹ MSTC is the Motor Start Time Constant and is defined as the Locked Rotor Time (par. 1-2) when the Locked Rotor Current is 600% of FLC.

5.2 AAC Adaptive Acceleration Control

AAC Adaptive Acceleration Control is a new form of motor control based on the motor's own performance characteristics. With AAC, the user selects the starting or stopping profile that best matches the load type and the starter automatically controls the motor to match the profile. The MCD 500 offers three profiles - early, constant and late acceleration and deceleration.

AAC uses two algorithms, one to measure the motor's characteristics and one to control the motor. The MCD 500 uses the first start to determine the motor's characteristics at

zero speed and at maximum speed. During each subsequent start and stop, the starter dynamically adjusts its control to ensure the motor's actual performance matches the selected profile throughout the start. The starter increases power to the motor if the actual speed is too low for the profile, or decreases power if the speed is too high.

5.3 Starting Modes

5.3.1 Constant Current

5

Constant current is the traditional form of soft starting, which raises the current from zero to a specified level and keeps the current stable at that level until the motor has accelerated.

Constant current starting is ideal for applications where the start current must be kept below a particular level.

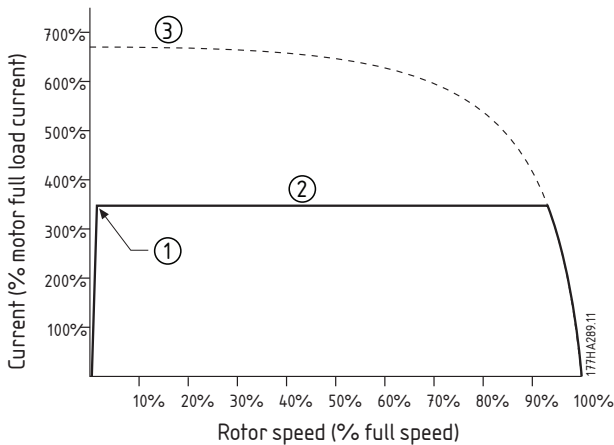

1: Initial current (Par. 1-5)
2: Current limit (Par. 1-4)
3: Full voltage current

5.3.2 Current Ramp

Current ramp soft starting raises the current from a specified starting level (1) to a maximum limit (3), over an extended period of time (2).

Current ramp starting can be useful for applications where:

- the load can vary between starts (for example a conveyor which may start loaded or unloaded). Set the initial current (Par. 1-5) to a level that will start the motor with a light load, and the current limit (Par. 1-4) to a level that will start the motor with a heavy load.
- the load breaks away easily, but starting time needs to be extended (for example a centrifugal

pump where pipeline pressure needs to build up slowly).

- the electricity supply is limited (for example a generator set), and a slower application of load will allow greater time for the supply to respond.

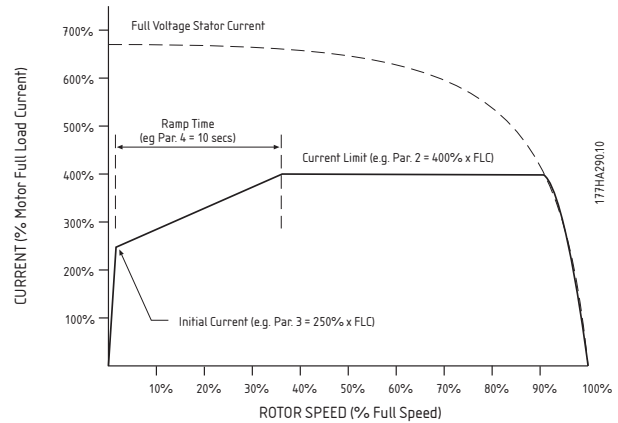

5.3.3 AAC Adaptive Acceleration Control

To use AAC Adaptive Acceleration Control to control starting performance:

- Select Adaptive Control from the Start Mode menu (Par. 1-3)
- Set the desired Start Ramp Time (Par. 1-6)
- Select the desired Adaptive Start Profile (Par. 1-13)
- Set a start Current Limit (Par. 1-4) sufficiently high to allow a successful start. The first AAC start will be a Constant Current start. This allows the MCD 500 to learn the characteristics of the connected motor. This motor data is used by the MCD 500 during subsequent AAC Adaptive Acceleration Control starts.

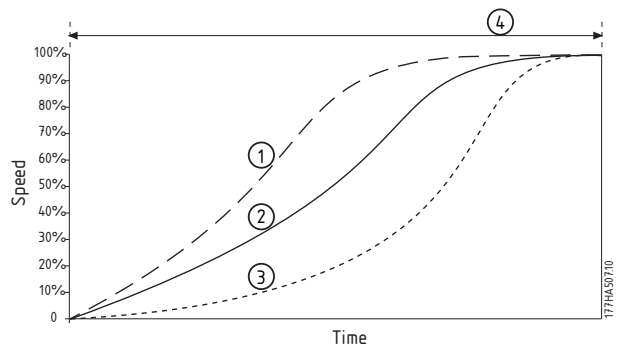

1. Early acceleration
2. Constant acceleration
3. Late acceleration
4. Start ramp time (Par. 1-6)

Table 5.1 Adaptive Start Profile (Par. 1-13)

NOTE

AAC Adaptive Acceleration Control will control the load according to the programmed profile. Start current will vary according to the selected acceleration profile and the programmed start time.

If replacing a motor connected to an MCD 500 programmed for AAC Adaptive Control starting or stopping, or if the starter has been tested on a different motor prior to actual installation, the starter will need to learn the characteristics of the new motor. The MCD 500 will automatically re-learn the motor's characteristics if Par. 1-1 *Motor Full Load Current* or Par. 1-12 *Adaptive Control Gain* is changed.

5.3.4 Kickstart

Kickstart provides a short boost of extra torque at the beginning of a start, and can be used in conjunction with current ramp or constant current starting.

Kickstart can be useful to help start loads that require high breakaway torque but then accelerate easily (for example flywheel loads such as presses).

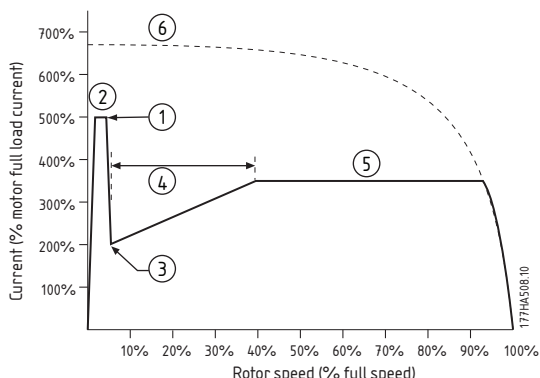

1: Kickstart level (Par. 1-7)
2: Kickstart time (Par. 1-8)
3: Initial current (Par. 1-5)
4: Start ramp time (Par. 1-6)
5: Current limit (Par. 1-4)
6: Full voltage current

5.4 Stopping Modes

5.4.1 Coast to Stop

Coast to stop lets the motor slow at its natural rate, with no control from the soft starter. The time required to stop will depend on the type of load.

5.4.2 TVR Soft Stop

Timed voltage ramp reduces the voltage to the motor gradually over a defined time. The load may continue to run after the stop ramp is complete.

Timed voltage ramp stopping can be useful for applications where the stop time needs to be extended, or to avoid transients on generator set supplies.

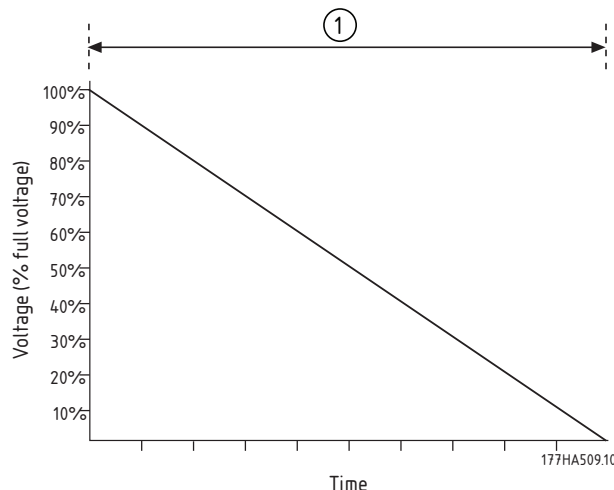

1: Stop time (Par. 1-11)

5.4.3 AAC Adaptive Acceleration Control

To use AAC Adaptive Acceleration Control to control stopping performance:

1. Select Adaptive Control from the Stop Mode menu (Par. 1-10)
2. Set the desired Stop Time (Par. 1-11)
3. Select the required Adaptive Stop Profile (Par. 1-14)

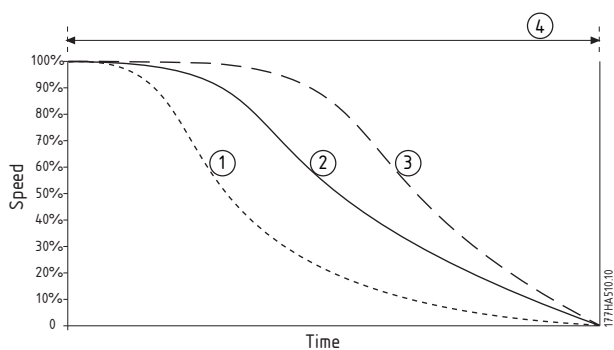

1. Early deceleration
2. Constant deceleration
3. Late deceleration
4. Stop time (Par. 1-10)

Table 5.2 AAC Adaptive Stop Profile (Par. 1-14)

NOTE

Adaptive control does not actively slow the motor down and will not stop the motor faster than a coast to stop. To shorten the stopping time of high inertia loads, use brake.

The first AAC Adaptive Deceleration Control stop will be a normal soft stop. This allows the MCD 500 to learn the characteristics of the connected motor. This motor data is used by the MCD 500 during subsequent Adaptive Control stops.

NOTE

Adaptive Control will control the load according to the programmed profile. Stopping current will vary according to the selected deceleration profile and stop time. If replacing a motor connected to an MCD 500 programmed for AAC Adaptive Control starting or stopping, or if the starter has been tested on a different motor prior to actual installation, the starter will need to learn the characteristics of the new motor. The MCD 500 will automatically re-learn the motor's characteristics if Par. 1-1 Motor Full Load Current or Par. 1-12 Adaptive Control Gain is changed.

5.4.4 Brake

NOTE

If the brake torque is set too high, the motor will stop before the end of the brake time and the motor will suffer unnecessary heating which could result in damage.

MCD 500 braking:

- Does not require the use of a DC brake contactor
- Controls all three phases so that the braking currents and associated heating is evenly distributed through the motor.

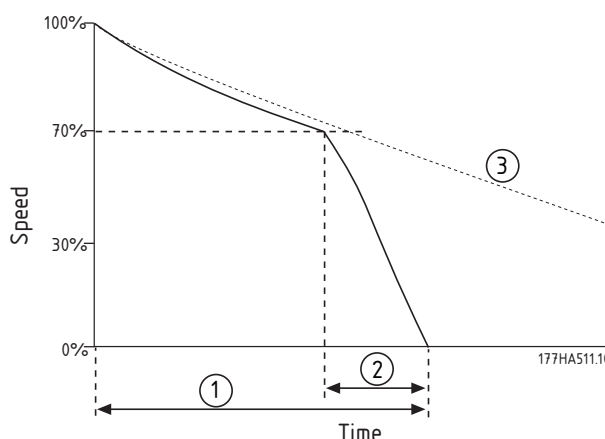

1: Stop time (Par. 1-11)
2: Brake time (Par. 1-16)
3: Coast to stop time

Braking has two stages:

1. Pre-brake: Provides an intermediate level of braking to slow motor speed to a point where full brake can be operated successfully (approximately 70% speed).
2. Full brake: Brake provides maximum braking torque, but is ineffective at speeds greater than approximately 70%.

To configure the MCD 500 for brake operation:

1. Set Par. 1-11 for the desired stopping time duration (1). This is the total braking time and must be set sufficiently longer than the brake time (Par 1-16) to allow the pre-braking stage to reduce motor speed to approximately 70. If the stop time is too short, braking will not be successful and the motor will coast to stop.
2. Set Brake Time (Par. 1-16) to approximately one quarter of the programmed Stop Time. This sets the time for the Full Brake stage (2).
3. Adjust the Brake Torque (Par. 1-15) so that the desired stopping performance is achieved. If set too low, the motor will not stop completely and will coast to stop by the end of the braking period.

Contact your local supplier for further information for installations using an external zero-speed sensor (e.g. applications with variable load during the braking cycle).

5.5 Jog Operation

Jog runs the motor at reduced speed, to allow alignment of the load or to assist servicing. The motor can be jogged in either forward or reverse direction.

The maximum available torque for jog is approximately 50% - 75% of motor full load torque (FLT) depending on the motor. Available jog torque in reverse is approximately 50% - 75% of the jog torque in forward direction. To set the jog torque level, use Par. 15-8.

NOTE

Setting Par. 15-8 above 50% may cause increased shaft vibration.

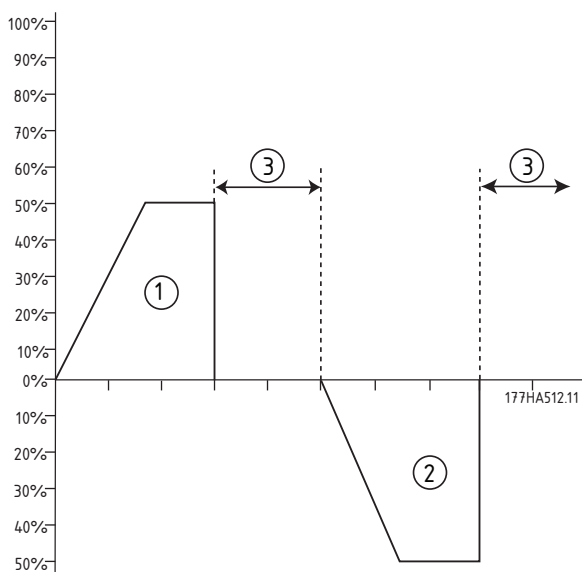

1. Jog Forward
2. Jog Reverse
3. Normal Operation

To activate jog operation, use a programmable input (Par. 3-3 *Input A Function*).

To stop a jog operation, perform either of the following:

- Remove the jog command
- Press the OFF button on the LCP
- Activate Emergency Stop using the LCP programmable inputs

Jog will recommence at the end of a restart delay if the jog command is still present. All other commands except the above will be ignored during jog operation.

NOTE

Jog will operate in 2-wire mode regardless of the state of the remote Start, Stop and Reset inputs.

NOTE

Jog is only available for the primary motor (for more information on primary and secondary sets, see Secondary motor set. Soft start and soft stop are not available during jog operation.

CAUTION

Slow speed running is not intended for continuous operation due to reduced motor cooling. Jog changes the motor's heating profile and reduced the accuracy of the motor thermal model. Do not rely on motor overload protection to protect the motor during jog operation.

5

5.6 Inside Delta Operation

AAC, Jog and Brake functions are not supported in inside delta (six-wire) operation. If these functions are programmed when the starter is connected inside delta the behaviour is as given below:

AAC Start	The starter performs a Constant Current Start.
AAC Stop	The starter performs a TVR Soft Stop if Stop Time is >0 secs. If Stop Time is set to 9 secs the starter performs a Coast to Stop.
Jog	The starter issues a warning with the error message Unsupported Option.
Brake	The starter performs a Coast to Stop.

NOTE

When connected in inside delta, current imbalance is the only phase loss protection that is active during run. Do not disable current imbalance protection during inside delta operation.

NOTE

Inside delta operation is only possible with mains voltage ≤ 600 VAC.

5.7 Typical Start Currents

Use this information to determine the appropriate start current for your application.

NOTE

These start current requirements are appropriate and typical in most circumstances, However, the performance and start torque requirements of motors and machines do vary. For further assistance, contact your local supplier.

Application	Typical Start Current
General & Water	
Agitator	4.0 x FLC
Centrifugal pump	3.5 x FLC
Compressor (Screw, unloaded)	3.0 x FLC
Compressor (Reciprocating, unloaded)	4.0 x FLC
Conveyor	4.0 x FLC
Fan (damped)	3.5 x FLC
Fan (undamped)	4.5 x FLC
Mixer	4.5 x FLC
Positive displacement pump	4.0 x FLC
Submersible pump	3.0 x FLC
Metals & Mining	
Belt conveyor	4.5 x FLC
Dust collector	3.5 x FLC
Grinder	3.0 x FLC
Hammer mill	4.5 x FLC
Rock crusher	4.0 x FLC
Roller conveyor	3.5 x FLC
Roller mill	4.5 x FLC
Tumbler	4.0 x FLC
Wire draw machine	5.0 x FLC
Food Processing	
Bottle washer	3.0 x FLC
Centrifuge	4.0 x FLC
Dryer	4.5 x FLC
Mill	4.5 x FLC
Palletiser	4.5 x FLC
Separator	4.5 x FLC
Slicer	3.0 x FLC
Pulp and Paper	
Dryer	4.5 x FLC
Re-pulper	4.5 x FLC
Shredder	4.5 x FLC
Petrochemical	
Ball mill	4.5 x FLC
Centrifuge	4.0 x FLC
Extruder	5.0 x FLC
Screw conveyor	4.0 x FLC
Transport & Machine Tool	
Ball mill	4.5 x FLC
Grinder	3.5 x FLC
Material conveyor	4.0 x FLC
Palletiser	4.5 x FLC
Press	3.5 x FLC
Roller mill	4.5 x FLC
Rotary table	4.0 x FLC
Lumber & Wood products	
Bandsaw	4.5 x FLC
Chipper	4.5 x FLC
Circular saw	3.5 x FLC
Debarker	3.5 x FLC
Edger	3.5 x FLC
Hydraulic power pack	3.5 x FLC
Planer	3.5 x FLC
Sander	4.0 x FLC

5.8 Installation with Main Contactor

The MCD 500 is installed with a main contactor (AC3 rated). Control voltage must be supplied from the input side of the contactor.

The main contactor is controlled by the MCD 500 Main Contactor output, which by default is assigned to Output Relay A (terminals 13, 14).

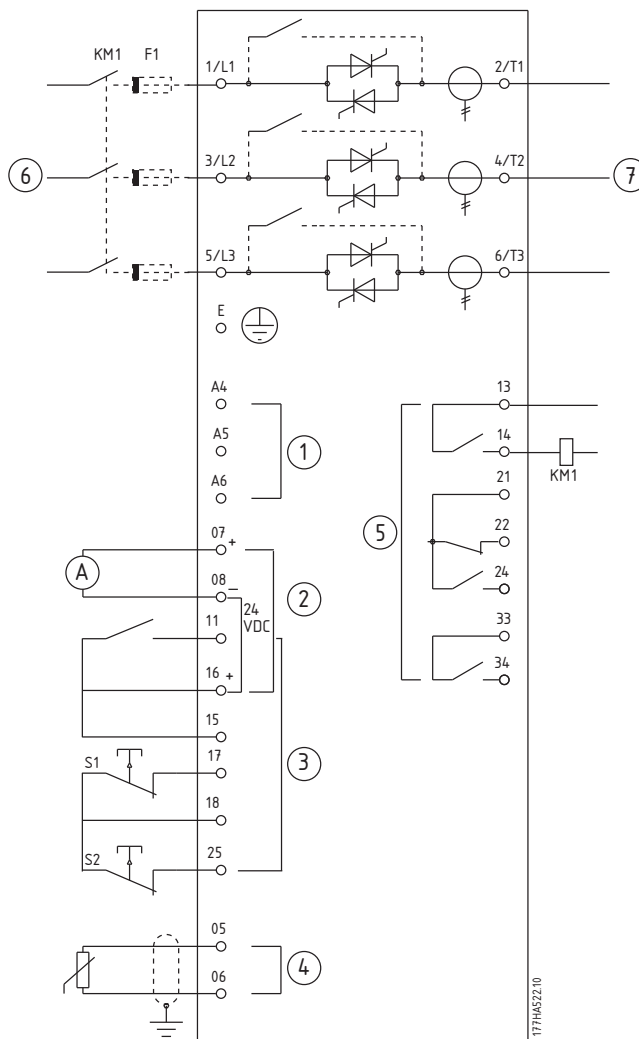

1	Control voltage (model dependent)	KM1	Main contactor
2	24 VDC output	F1	Semiconductor fuses (optional)
3	Remote control inputs	S1	Start /stop
4	Motor thermistor input (PTC only)	S2	Reset contact
5	Relay outputs	13, 14	Relay output A
6	3-phase supply	21, 22, 24	Relay output B
7	Motor terminals	33, 34	Relay output C

Parameter settings:

- Par. 4-1 *Relay A Function*
 - Select Main Contactor - assigns the Main Contactor function to Relay Output A (default value).

5.9 Installation with Bypass Contactor

The MCD 500 is installed with a bypass contactor (AC1 rated). The bypass contactor is controlled by the MCD 500 Run Output which by default is assigned to Output Relay B (terminals 21, 22, 24).

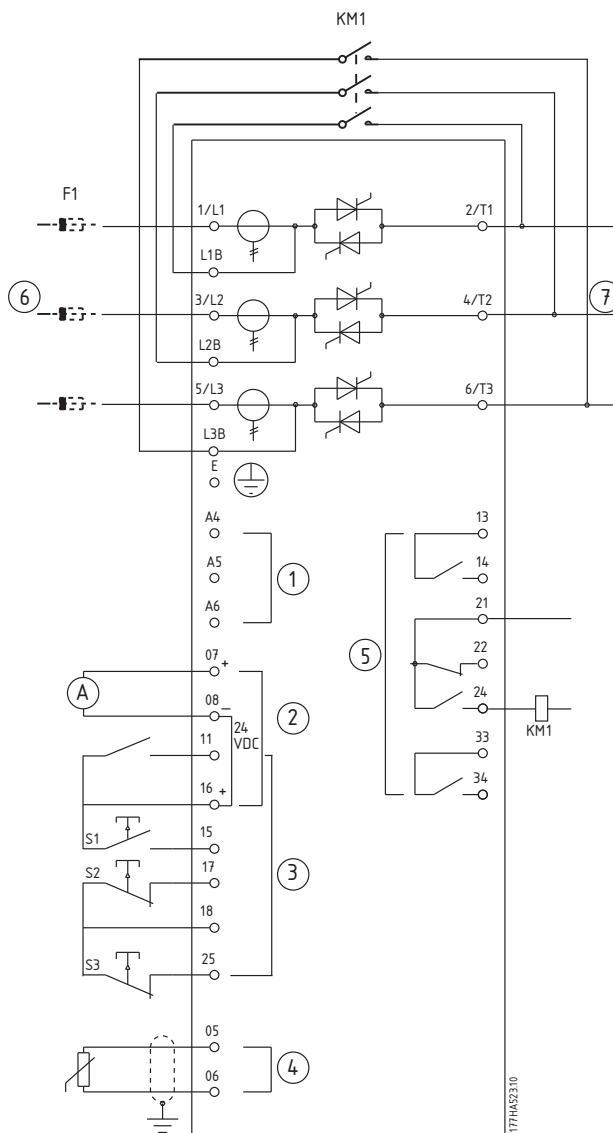

1	Control voltage (model dependent)	KM1	Bypass contactor
2	24 VDC output	F1	Semiconductor fuses (optional)
3	Remote control inputs	S1	Start contact
4	Motor thermistor input (PTC only)	S2	Stop contact
5	Relay outputs	S3	Reset contact
6	3-phase supply	13, 14	Relay output A
7	Motor terminals	21, 22, 24	Relay output B
		33, 34	Relay output C

Parameter settings:

- Parameter 4-4 *Relay B Function*
 - Select Run - assigns the run output function to Relay Output B (default value).

5.10 Emergency Run Operation

In normal operation the MCD 500 is controlled via a remote two wire signal (terminals 17, 18).

Emergency Run is controlled by a two wire circuit connected to Input A (terminals 11, 16). Closing Input A causes the MCD 500 to run the motor and ignore all trip conditions.

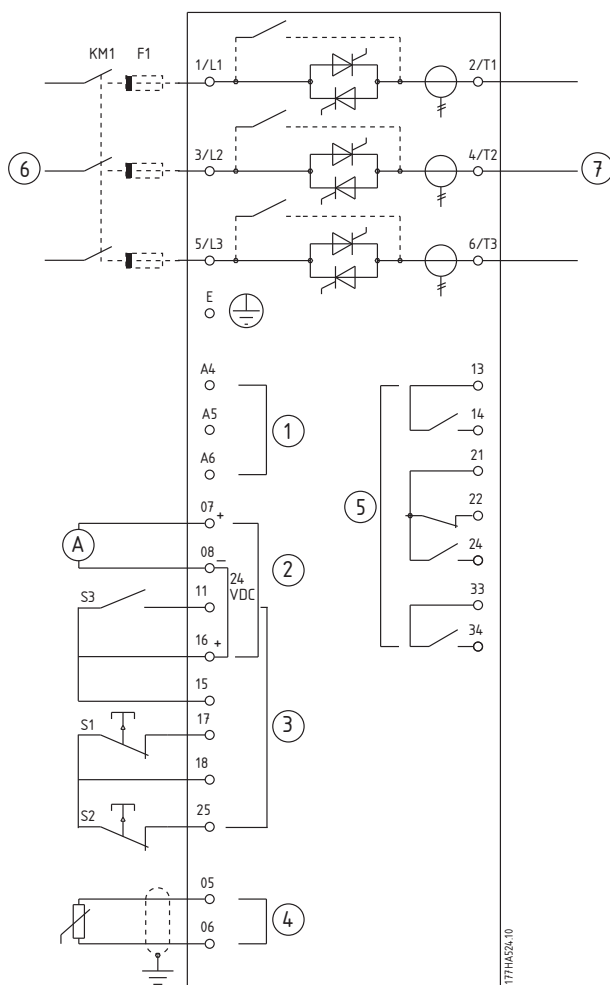

5

1	Control voltage (model dependent)	S1	Start/stop contact
2	24 VDC output	S2	Reset contact
3	Remote control inputs	S3	Emergency Run contact
4	Motor thermistor input (PTC only)	13, 14	Relay output A
5	Relay outputs	21, 22, 24	Relay output B
6	3-phase supply	33, 34	Relay output C
7	Motor terminals		

Parameter settings:

- Par. 3-3 *Input A Function*
 - Select Emergency Run - assigns Input A to Emergency Run Function
- Par. 15-3 (*Emergency Run*)
 - Select Enable - Enables the Emergency Run mode

5.11 Auxiliary Trip Circuit

In normal operation the MCD 500 is controlled via a remote two wire signal (terminals 17, 18).

Input A (terminals 11, 16) is connected to an external trip circuit (such as a low pressure alarm switch for a pumping system). When the external circuit activates, the soft starter trips, which stops the motor.

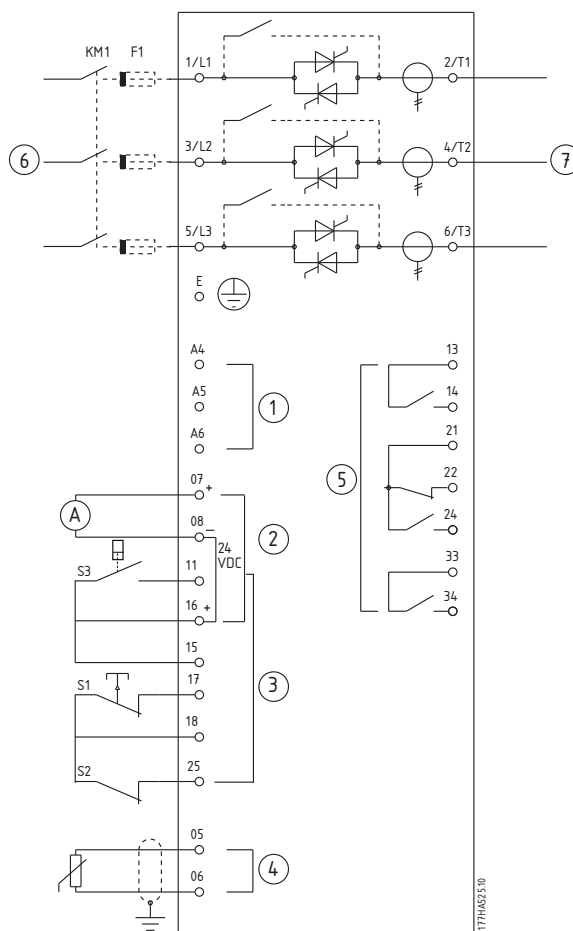

1	Control voltage (model dependent)	S1	Start/stop contact
2	24 VDC output	S2	Reset contact
3	Remote control inputs	S3	Auxiliary trip contact
4	Motor thermistor input (PTC only)	13, 14	Relay output A
5	Relay outputs	21, 22, 24	Relay output B
6	3-phase supply	33, 34	Relay output C
7	Motor terminals		

Parameter settings:

- Par. 3-3 *Input A Function*
 - Select Input Trip (N/O) assigns the Input A to Auxiliary Trip (N/O) function
- Par. 3-4 *Input A Name*
 - Select a name e.g. Low Pressure - assigns a name to Input A.
- Par. 3-8 *Remote Reset Logic*
 - Select as required e.g. Normally Closed - the input behaves like a normally closed contact.

5.12 Soft Braking

For high inertia loads the MCD 500 can be configured for soft braking.

In this application the MCD 500 is employed with forward run and braking contactors. When MCD 500 receives a start signal (button S1), it closes the forward run contactor (KM1) and controls the motor according to the programmed primary motor settings.

When the MCD 500 receives a stop signal (button S2), it opens the forward run contactor (KM1) and closes the braking contactor (KM2) after a delay of approximately 2-3 seconds (KT1). KA3 is also closed to activate the secondary motor settings, which should be user programmed for the desired stopping performance characteristics.

When motor speed approaches zero, the external shaft rotation sensor (A2) stops the soft starter and opens the braking contactor (KM2).

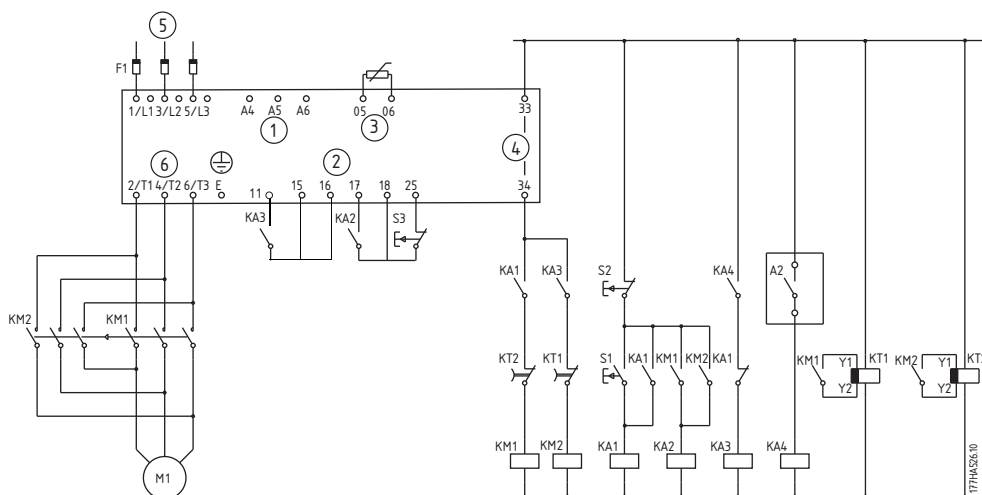

1	Control voltage (model dependent)	KA3	Brake relay
2	Remote control inputs	KA4	Rotation sensing relay
3	Motor thermistor input (PTC only)	KM1	Line contactor (Run)
4	Relay outputs	KM2	Line contactor (Brake)
5	3-phase supply	KT1	Run delay timer
6	Motor terminals	KT2	Brake delay timer
A2	Shaft rotation sensor	S1	Start contact
KA1	Run relay	S2	Stop contact
KA2	Start relay	S3	Reset contact

Parameter settings:

- Par. 3-3 *Input A Function*
 - Select Motor Set Select - assigns Input A for Motor set selection
 - Set starting performance characteristics using the primary motor set (parameter group 1)
 - Set braking performance characteristics using the secondary motor settings (parameter group 7)
- Par. 4-7 *Relay C Function*
 - Select Trip - assigns Trip function to Relay Output C

NOTE

If the MCD-500 trips on supply frequency (Par. 16-5 Frequency) when the braking contactor KM2 opens, modify the setting of Pars. 2-8 - 2-10.

5.13 Two Speed Motor

The MCD 500 can be configured for control of dual speed Dahlander type motors, using a high speed contactor (KM1), low speed contactor (KM2) and a star contactor (KM3).

When the soft starter receives a high speed start signal, it closes the high speed contactor (KM1) and star contactor (KM3), then controls the motor according to the primary motor settings (par. 1-1 - 1-16.)

NOTE

Pole Amplitude Modulated (PAM) motors alter the speed by effectively changing the stator frequency using external winding configuration. Soft starters are not suitable for use with this type of two-speed motor.

When the soft starter receives a low speed start signal, it closes the low speed contactor (KM2). This closes Input A and the MCD 500 controls the motor according to the secondary motor settings (par. 7-1 - 7-16).

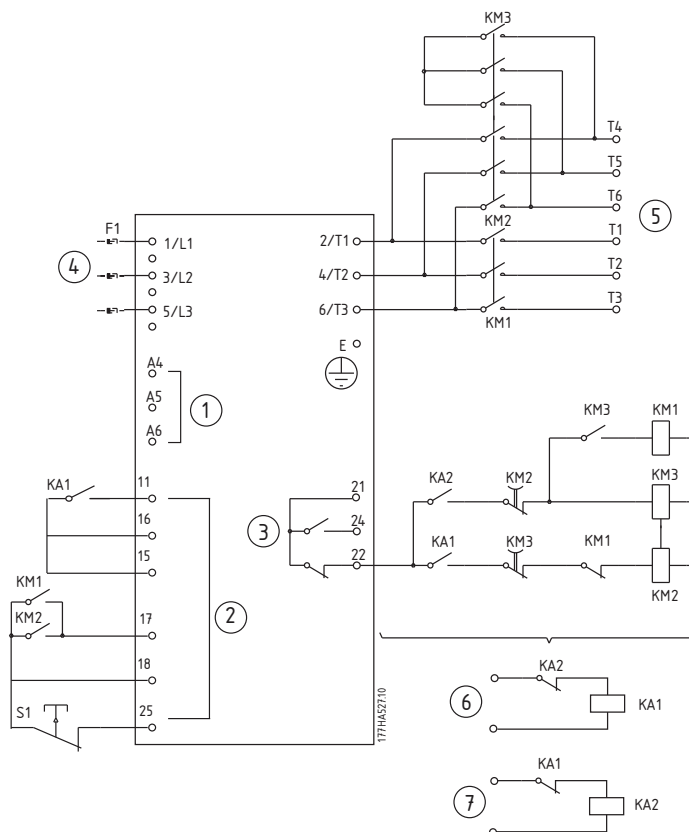

1	Control voltage	KA1	Remote start relay (low speed)
2	Remote control inputs	KA2	Remote start relay (high speed)
3	Relay outputs	KM1	Line contactor (high speed)
4	3-phase supply	KM2	Line contactor (low speed)
5	Motor terminals	KM3	Star contactor (high speed)
6	Remote low-speed start input	S1	Reset contact
7	Remote high-speed start input	21, 22, 24	Relay output B

NOTE

Contactors KM2 and KM3 must be mechanically interlocked.

Parameter settings:

- Par. 3-3 *Input A Function*
 - Select Motor Set Select - assigns Input A for Motor set selection
 - Set high speed performance characteristics using par. 1-1 - 2-9
 - Set low speed performance characteristics using par. 7-1 - 7-16.
- Par. 4-4 *Relay B Function*
 - Select Trip - assigns Trip function to Relay Output B

NOTE

If the MCD 500 trips on supply frequency (Par. 16-5 *Frequency*) when the high-speed start signal (7) is removed, modify the setting of pars. 2-8 - 2-10.

6 Operation

6.1 Operation and LCP

6.1.1 Operating Modes

In Hand On mode:

- To soft start the motor, press **[HAND ON]** on the LCP
- To stop the motor, press **[OFF]** on the LCP
- To reset a trip on the starter, press **[RESET]** on the LCP
- To emergency stop the motor, press the local **[OFF]** and **[RESET]** buttons at the same time. The soft starter will remove power from the motor and open the main contactor, and the motor will coast to stop. Emergency stop can also be controlled via a programmable input.

In Auto On mode:

- To soft start the motor, activate the Start remote input
- To stop the motor, activate the Stop remote input
- To reset a trip on the starter, activate the Reset remote input

NOTE

Brake and Jog functions operate only with in-line connected motors (see Inside Delta Operation)

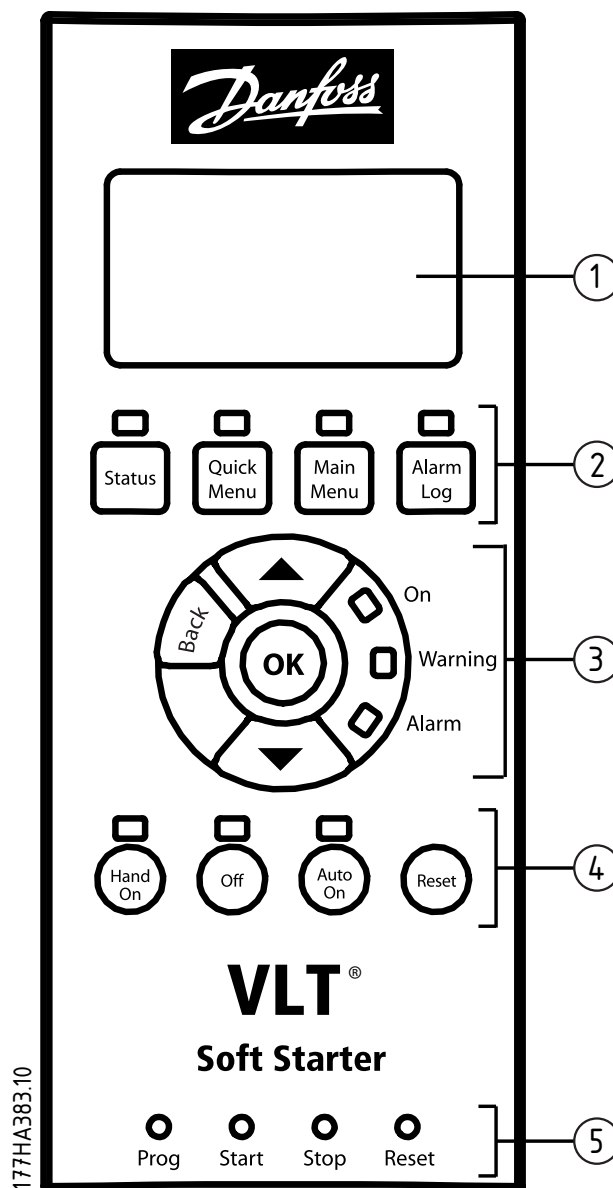

1	Four-line display for status and programming details.
2	Display control buttons: Status: Return to the status displays Quick Menu: Open the Quick Menu Main Menu: Open the Main Menu Alarm Log: Open the Alarm Log
3	Menu navigation buttons: BACK: Exit the menu or parameter, or cancel a parameter change OK: Enter a menu or parameter, or save a parameter change ▲ ▼: Scroll to the next or previous menu or parameter, change the setting of the current parameter or scroll through the status screens.
4	Soft starter local control buttons: Hand On: Start the motor and enter local control mode. Off: Stop the motor (only active in Hand On mode). Auto On: Set the starter to Auto On mode. RESET: Reset a trip (Hand On mode only).
5	Remote input status LEDs.

- Local control is only available in Hand On mode.
- Remote control is only available in Auto On mode.
- Control via the serial communication network is always disabled in Hand On mode, and Start/Stop commands via the serial network may be enabled or disabled in Auto On mode by changing the setting of Par. 3-2 *Comms in Remote*.

The MCD 500 can also be configured to auto-start or auto-stop. Auto-start/stop operation is only available in Auto On mode, and must be configured using pars. 5-1 - 5-4. In Hand On mode, the starter will ignore any auto-start/stop setting.

To switch between Hand On and Auto On modes, use the local control buttons on the LCP.

HAND ON: Start the motor and enter Hand On mode.
OFF: Stop the motor and enter Hand On mode.
AUTO ON: Set the starter to Auto On mode.
RESET: Reset a trip (Hand On mode only).

The MCD 500 can also be set to allow local control only or remote control only, using par. 3-1 *Local/Remote*.

If par. 3-1 is set to *Remote Control Only*, the OFF button is disabled and the motor must be stopped by remote control or via the serial communication network.

6.2 Control Methods

The MCD 500 can be controlled via the control buttons on the LCP (local control), via the remote inputs (remote control) or via the serial communication network.

	Hand On mode	Auto On mode
To soft start the motor	press the HAND ON button on the LCP	activate the Start remote input
To stop the motor	press the OFF button on the LCP	activate the Stop remote input
To reset a trip on the starter	press the RESET button on the LCP	activate the Reset remote input
Auto start/stop operation	Disabled	Enabled

To emergency stop the motor, press the local OFF and RESET buttons at the same time. The soft starter will remove power from the motor and open the main contactor, and the motor will coast to stop. Emergency stop can also be controlled via a programmable input.

NOTE

Brake and Jog functions operate only with in-line connected motors (see *Inside Delta Operation*)

6.3 Local Control Buttons

If Par. 3-1 is set to LCL/RMT Anytime or LCL/RMT When OFF, the **Hand On** and **Auto On** buttons are always active. If the MCD-500 is in Auto On mode, pressing the **Hand On** button will enter Hand On mode and start the motor.

If Par. 3-1 is set to Remote Control Only, the **Off** button is disabled and the motor must be stopped by remote control or via the serial communication network.

6.4 Displays

The LCP displays a wide range of performance information about the soft starter. Press the **STATUS** button to access the status display screens, then use the ▲ and ▼ buttons to select the information to display. To return to the status screens from within a menu, press the **BACK** button repeatedly or press the **STATUS** button.

- Temperature monitoring
- Programmable screen (see Par. 8-2 - 8-5)
- Current
- Frequency
- Motor power
- Last start information
- Date and time
- SCR Conduction bar-graph
- Performance graphs

NOTE

Screens shown here are with the default settings.

6.4.1 Temperature Monitoring Screen (S1)

The temperature screen shows the temperature of the motor as a percentage of total thermal capacity, and also shows which motor data set is in use.

The temperature monitoring screen is the default status screen.

Ready			S1
MS1	000.0A	000.0kW	
	Primary Motor Set		
M1	000%		

6.4.2 Programmable Screen (S2)

The MCD 500's user-programmable screen can be configured to show the most important information for the particular application. Use parameters 8-2 to 8-5 to select which information to display.

Ready			S2
MS1	000.0A	000.0kW	
	-.- pf		
	00000 hrs		

6.4.3 Average Current (S3)

The average current screen shows the average current of all three phases.

Ready			S3
MS1	000.0A	000.0kW	
	0.0A		

6.4.4 Current Monitoring Screen (S4)

The current screen shows real-time line current on each phase.

Ready			S4
MS1	000.0A	000.0kW	
	Phase currents		
000.0A	000.0A	000.0A	

6.4.5 Frequency Monitoring Screen (S5)

The frequency screen shows the mains frequency as measured by the soft starter.

Ready			S5
MS1	000.0A	000.0kW	
	00.0Hz		

6.4.6 Motor Power Screen (S6)

The motor power screen shows motor power (kW, HP and kVA) and power factor.

Ready			S6
MS1	000.0A	000.0kW	
	000.0kW		0000HP
	0000kVA		-.- pf

6.4.7 Last Start Information (S7)

The last start information screen shows details of the most recent successful start:

- start duration (seconds)
- maximum start current drawn (as a percentage of motor full load current)
- calculated rise in motor temperature

Ready			S7
MS1	000.0A	000.0kW	
Last start			000 s
000 % FLC			ΔTemp 0%

6.4.8 Date and Time (S8)

The date/time screen shows the current system date and time (24 hour format). For details on setting the date and time, see *Set Date and Time*.

Ready		S8
MS1	000.0A	000.0kW
	YYYY MMM DD	
	HH:MM:SS	

6.4.9 SCR Conduction Bargraph

The SCR conduction bargraph shows the level of conduction on each phase.



6.4.10 Performance Graphs

The MCD 500 can display real-time performance information for:

- Current
- Motor temperature
- Motor kW
- Motor kVA
- Motor power factor

The newest information is displayed at the right hand edge of the screen. Older data is not stored. The graph can also be paused, to allow past performance to be analysed. To pause or unpause the graph, press and hold the OK button for more than 0.5 seconds.

NOTE

The MCD 500 will not collect data while the graph is paused. When graphing resumes, a small gap will be shown between the old data and the new data.

7 Programming

You can access the programming menus at any time, including while the soft starter is running. All changes take effect immediately.

7.1 Access Control

Critical parameters (parameter group 15 and higher) are protected by a four-digit security access code, preventing unauthorised users from viewing or modifying parameter settings.

When a user attempts to enter a restricted parameter group, the LCP prompts for an access code. The access code is requested once for the programming session, and authorisation continues until the user closes the menu.

To enter the access code, use the **BACK** and **OK** buttons to select a digit, and the **▲** and **▼** buttons to change the value. When all four digits match your access code, press **OK**. The LCP will display an acknowledgement message before continuing.

To change the access code, use par. 15-1.

Enter Access Code	
####	
	OK
Access Allowed	
SUPERVISOR	

NOTE

The protection simulation and output simulation are also protected by the security access code. The counters and thermal model reset can be viewed without entering an access code, but an access code must be entered in order to reset.

The default access code is 0000.

You can lock the menus to prevent users from altering parameter settings. The adjustment lock can be set to allow Read & Write, Read Only or No Access using Par. 15-2.

If a user attempts to change a parameter value or access the Main Menu when the adjustment lock is active, an error message is displayed:

Access Denied
Adj Lock is On

7.2 Quick Menu

7.2.1 Quick Setup

Quick setup provides access to commonly used parameters, allowing the user to configure the MCD 500 as required for the application. For details of individual parameters, see *Parameter Descriptions*.

1	Primary Mtr Set
1-1	Motor FLC
1-3	Start Mode
1-4	Current Limit
1-5	Initial Current
1-6	Start Ramp Time
1-9	Excess Start Time
1-10	Stop Mode
1-11	Stop Time
2	Protection
2-1	Phase Sequence
2-4	Undercurrent
2-5	Undercurrent Dly
2-6	Inst Overcurrent
2-7	Inst Overcurrent Dly
3	Inputs
3-3	Input A Function
3-4	Input A Name
3-5	Input A Trip
3-6	Input A Trip Dly
3-7	Input A Initial Dly
4	Outputs
4-1	Relay A Function
4-2	Relay A On Delay
4-3	Relay A Off Delay
4-4	Relay B Function
4-5	Relay B On Delay
4-6	Relay B Off Delay
4-7	Relay C Function
4-8	Relay C On Delay
4-9	Relay C Off Delay
4-10	Low Current Flag
4-11	High Current FFlag
4-12	Motor Temp Flag
5	Start/Stop Timers
5-1	Auto-Start Type
5-2	Auto-Start Time
5-3	Auto-Stop Type
5-4	Auto-Stop Time
8	Display
8-1	Language
8-2	User Scrn Top L
8-3	User Scrn Top R
8-4	User Scrn Btm L
8-5	User Scrn Btm R

7.2.2 Application Setups

The application setups menu makes it easy to configure the MCD 500 for common applications. The MCD 500 selects the parameters relevant to the application and suggests a typical setting, and you can adjust each parameter to suit your exact requirements.

On the display the highlighted values are suggested values and the values indicated by a ► are the loaded values.

Always set par. 1-1 *Motor FLC* to match the motor's nameplate full load current. The suggested value for motor FLC is the starter's minimum FLC.

7

Pump Centrifugal	Suggested Value	Compressor Recip	Suggested Value
Motor Full Load Current		Motor Full Load Current	
Start Mode	Adaptive Control	Start Mode	Constant Current
Adaptive Start Profile	Early Acceleration	Start Ramp Time	10 seconds
Start Ramp Time	10 seconds	Current Limit	450%
Stop Mode	Adaptive Control		
Adaptive Stop Profile	Late Deceleration		
Stop Time	15 seconds		
Pump Submersible		Conveyor	
Motor Full Load Current		Motor Full Load Current	
Start Mode	Adaptive Control	Start Mode	Constant Current
Adaptive Start Profile	Early Acceleration	Start Ramp Time	5 seconds
Start Ramp Time	5 seconds	Current Limit	400%
Stop Mode	Adaptive Control	Stop Mode	Adaptive Control
Adaptive Stop Profile	Late Deceleration	Adaptive Stop Profile	Constant Deceleration
Stop Time	5 seconds	Stop Time	10 seconds
Fan Damped		Crusher Rotary	
Motor Full Load Current		Motor Full Load Current	
Start Mode	Constant Current	Start Mode	Constant Current
Current Limit	350%	Start Ramp Time	10 seconds
		Current Limit	400%
		Excess Start Time	30 seconds
		Locked Rotor Time	20 seconds
Fan Undamped		Crusher Jaw	
Motor Full Load Current		Motor Full Load Current	
Start Mode	Adaptive Control	Start Mode	Constant Current
Adaptive Start Profile	Constant Acceleration	Start Ramp Time	10 seconds
Start Ramp Time	20 seconds	Current Limit	450%
Excess Start Time	30 seconds	Excess Start Time	40 seconds
Locked Rotor Time	20 seconds	Locked Rotor Time	30 seconds
Compressor Screw			
Motor Full Load Current			
Start Mode	Constant Current		
Start Ramp Time	5 seconds		
Current Limit	400%		

7.2.3 Loggings

The Loggings menu allows the user to view performance information in real-time graphs.

- Current (%FLC)
- Motor Temp (%)
- Motor kW (%)
- Motor kVA (%)
- Motor pf

The newest information is displayed at the right hand edge of the screen. The graph can be paused to analyse data by pressing and holding the OK button. To re-start the graph, press and hold OK.

7.3 Main Menu

The Main Menu button provides access to menus for setting up the MCD 500 for complex applications and for monitoring its performance.

7.3.1 Parameters

Parameters lets you view and change all programmable parameters that control how the MCD 500 operates.

To open Parameters, press the **Main Menu** button then select Parameters.

To navigate through Parameters:

- to scroll through parameter groups, press the **▲** or **▼** button.
- to view the parameters in a group, press the **OK** button.

- to return to the previous level, press the **BACK** button.
- to close Parameters, press the **BACK** button.

To change a parameter value:

- scroll to the appropriate parameter and press **OK** to enter edit mode.
- to alter the parameter setting, use the **▲** and **▼** buttons.
- to save changes, press **OK**. The setting shown on the display will be saved and the LCP will return to the parameter list.
- to cancel changes, press **Back**. The LCP will return to the parameter list without saving changes.

7.3.2 Parameter Shortcut

The MCD 500 also includes a parameter shortcut, which allows you to directly access a parameter within the Parameters menu.

- To access the parameter shortcut, press the **MAIN MENU** button for three seconds
- Use the **▲** or **▼** button to select the parameter group.
- Press **OK** or **BACK** to move the cursor.
- Use the **▲** or **▼** button to select the parameter number.

Parameter shortcut
Please enter a Parameter number 01-01



7.3.3 Parameter List

1	Primary Mtr Set	4	Outputs	7-11	Stop Time-2
1-1	Motor FLC	4-1	Relay A Function	7-12	Adaptv Ctrl Gain-2
1-2	Locked Rotor Time	4-2	Relay A On Delay	7-13	Adaptv Start Prof-2
1-3	Start Mode	4-3	Relay A Off Delay	7-14	Adaptv Stop Prof-2
1-4	Current Limit	4-4	Relay B Function	7-15	Brake Torque-2
1-5	Initial Current	4-5	Relay B On Delay	7-16	Brake Time-2
1-6	Start Ramp Time	4-6	Relay B Off Delay	8	Display
1-7	Kickstart Level	4-7	Relay C Function	8-1	Language
1-8	Kickstart Time	4-8	Relay C On Delay	8-2	User Scrn Top L
1-9	Excess Start Time	4-9	Relay C Off Delay	8-3	User Scrn Top R
1-10	Stop Mode	4-10	Low Current Flag	8-4	User Scrn Btm L
1-11	Stop Time	4-11	High Current FLag	8-5	User Scrn Btm R
1-12	Adaptv Control Gain	4-12	Motor Temp Flag	8-6	Graph Timebase
1-13	Adaptv Start Profile	4-13	Analog Output A	8-7	Graph Max Adj
1-14	Adaptv Stop Profile	4-14	Analog A Scale	8-8	Graph Min Adj
1-15	Brake Torque	4-15	Analog A Max Adj	8-9	Mains Ref Volt
1-16	Brake Time	4-16	Analog A Min Adj	15	Restrict Paramtr
2	Protection	5	Start/Stop Timers	15-1	Access Code
2-1	Phase Sequence	5-1	Auto-Start Type	15-2	Adjustment Lock
2-2	Current Imbalance	5-2	Auto-Start Time	15-3	Emergency Run
2-3	Current Imbal Dly	5-3	Auto-Stop Type	15-4	Current Calibrat
2-4	Undercurrent	5-4	Auto-Stop Time	15-5	Main Cont Time
2-5	Undercurrent Dly	6	Auto-Reset	15-6	Bypass Cont Time
2-6	Inst Overcurrent	6-1	Auto-Reset Action	15-7	Motor Connection
2-7	Inst Ocrnt Dly	6-2	Maximum Resets	15-8	Jog Torque
2-8	Frequency Check	6-3	Reset Dly Grp A & B	16	Protection Action
2-9	Freq Variation	6-4	Reset Delay Grp C	16-1	Motor Overload
2-10	Frequency Delay	7	Secondary Mtr Set	16-2	Current Imbalance
2-11	Restart Delay	7-1	Motor FLC-2	16-3	Undercurrent
2-12	Motor Temp Check	7-2	Lock Rotor Time-2	16-4	Inst Overcurrent
3	Inputs	7-3	Start Mode-2	16-5	Frequency
3-1	Local/Remote	7-4	Current Limit-2	16-6	Heatsink Overtemp
3-2	Comms in Remote	7-5	Initial Crnt-2	16-7	Excess Start Time
3-3	Input A Function	7-6	Start Ramp-2	16-8	Input A Trip
3-4	Input A Name	7-7	Kickstart Lvl-2	16-9	Motor Thermistor
3-5	Input A Trip	7-8	Kickstart Time-2	16-10	Starter Comms
3-6	Input A Trip Dly	7-9	Excess Strt Time-2	16-11	Network Comms
3-7	Input A Initial Dly	7-10	Stop Mode-2	16-12	Battery/Clock
3-8	Remote Reset Logic				

7.4 Primary Motor Settings

NOTE

Default settings are marked with *.

The parameters in Primary Motors Settings configure the soft starter to match the connected motor. These parameters describe the motor's operating characteristics and allow the soft starter to model the motor's temperature.

1-1 Motor FLC

Option:	Function:
Model dependent	Matches the starter to the connected motor's full load current. Set to the full load current (FLC) rating shown on the motor nameplate.

1-2 Locked Rotor Time

Range:	Function:
10 secs* [0:01 - 2:00 (min:sec)]	Sets the maximum length of the time the motor can run at locked rotor current from cold before reaching its maximum temperature. Set according to the motor datasheet. If this information is not available, we recommend the value should be less than 20 seconds.

1-3 Start Mode

Option:	Function:
	Selects the soft start mode. See <i>Starting Modes</i> in chapter <i>Application Examples</i> for more details.
Constant Current*	
Adaptive Control	

1-4 Current Limit

Range:	Function:
350%* [100% - 600% FLC]	Sets the current limit for constant current and current ramp soft starting, as a percentage of motor full load current. See <i>Starting Modes</i> in chapter <i>Application Examples</i> for more details.

1-5 Initial Current

Range:	Function:
350%* [100% - 600% FLC]	Sets the initial start current level for current ramp starting, as a percentage of motor full load current. Set so that the motor begins to accelerate immediately after a start is initiated. If current ramp starting is not required, set the initial current equal to the current limit. See <i>Starting Modes</i> in chapter <i>Application Examples</i> for more details.

1-6 Start Ramp Time

Range:	Function:
10 secs* [1 - 180 secs]	Sets the total start time for an AAC Adaptive Control start or the ramp time for current ramp starting (from the initial current to the current limit). See <i>Starting Modes</i> in chapter <i>Application Examples</i> for more details.

1-7 Kickstart Level

Range:	Function:
500%* [100% - 700% FLC]	Sets the level of the kickstart current. CAUTION Kickstart subjects the mechanical equipment to increased torque levels. Ensure the motor, load and couplings can handle the additional torque before using this feature.

1-8 Kickstart Time

Range:	Function:
0000 msec* [0 - 2000 msec]	Sets the kickstart duration. A setting of 0 disables kickstart. See <i>Starting Modes</i> in chapter <i>Application Examples</i> for more details. CAUTION Kickstart subjects the mechanical equipment to increased torque levels. Ensure the motor, load and couplings can handle the additional torque before using this feature.

1-9 Excess Start Time

Range:	Function:
	Excess start time is the maximum time the MCD 500 will attempt to start the motor. If the motor does not reach full speed within the programmed limit, the starter will trip. Set for a period slightly longer than required for a normal healthy start. A setting of 0 disables excess start time protection.
20 sec* [0:00 - 4:00 (min:secs)]	Set as required.

1-10 Stop Mode

Option:	Function:
	Selects the stop mode. See <i>Stopping Modes</i> in chapter <i>Application Examples</i> for more details.
Coast to Stop*	
TVR Soft Stop	
Adaptive Control	
Brake	

7

7

1-11 Stop Time

Range:		Function:
0 secs*	[0:00 - 4:00 (min:secs)]	Sets the time for soft stopping the motor using timed voltage ramp or Adaptive Control (AAC). If a main contactor is installed, the contactor must remain closed until the end of the stop time. Use a programmable output configured to Run to control the main contactor. Sets the total stopping time when using brake. See <i>Stopping Modes</i> in chapter <i>Application Examples</i> for more details.

1-12 Adaptive Control Gain

Range:		Function:
75%*	[1% - 200%]	Adjusts the performance of AAC adaptive acceleration control. This setting affects both starting and stopping control. NOTE We recommend leaving the gain setting at the default level unless AAC performance is not satisfactory. If the motor accelerates or decelerates quickly at the end of a start or stop, increase the gain setting by 5%~10%. If the motor speed fluctuates during starting or stopping, decrease the gain setting slightly.

1-13 Adaptive Start Profile

Option:	Function:
	Selects which profile the MCD 500 will use for an AAC adaptive acceleration control soft start. See <i>Starting Modes</i> in chapter <i>Application Examples</i> for more details.
Early Acceleration	
Constant Acceleration*	
Late Acceleration	

1-14 Adaptive Stop Profile

Option:	Function:
	Selects which profile the MCD 500 will use for an AAC adaptive acceleration control soft stop. See <i>Stopping Modes</i> in chapter <i>Application Examples</i> for more details.
Early Deceleration	
Constant Deceleration*	
Late Acceleration	

7.4.1 Brake

Brake uses DC injection to actively slow the motor. See *Stopping Modes* in chapter *Application Examples* for more details.

1-15 Brake Torque

Range:		Function:
20%*	[20 - 100%]	Sets the amount of brake torque the MCD 500 will use to slow the motor.

1-16 Brake Time

Range:		Function:
1 sec*	[1 - 30 secs]	Sets the duration for DC injection during a braking stop. NOTE Parameter 1-16 is used in conjunction with Par. 1-11. See <i>Brake</i> for details.

7.5 Protection

2-1 Phase Sequence

Option:	Function:
	Selects which phase sequences the soft starter will allow at a start. During its pre-start checks, the starter examines the sequence of the phases at its input terminals and trips if the actual sequence does not match the selected option.
Any sequence*	
Positive only	
Negative only	

7.5.1 Current Imbalance

The MCD 500 can be configured to trip if the currents on the three phases vary from each other by more than a specified amount. The imbalance is calculated as the difference between the highest and lowest currents on all three phases, as a percentage of the highest current.

Current imbalance detection is desensitised by 50% during starting and soft stopping.

2-2 Current Imbalance

Range:		Function:
30%*	[10% - 50%]	Sets the trip point for current imbalance protection.

2-3 Current Imbalance Delay

Range:		Function:
3 secs*	[0:00 - 4:00 (min:secs)]	Slows the MCD 500's response to current imbalance, avoiding trips due to momentary fluctuations.

7.5.2 Undercurrent

The MCD 500 can be configured to trip if the average current of all three phases drops below a specified level while the motor is running.

2-4 Undercurrent

Range:		Function:
20%*	[0% - 100%]	Sets the trip point for undercurrent protection, as a percentage of motor full load current. Set to a level between the motor's normal working range and the motor's magnetising (no load) current (typically 25% to 35% of full load current). A setting of 0% disables undercurrent protection.

2-5 Undercurrent Delay

Range:		Function:
5 secs*	[0:00 - 4:00 (min:secs)]	Slows the MCD 500's response to undercurrent, avoiding trips due to momentary fluctuations.

7.5.3 Instantaneous Overcurrent

The MCD 500 can be configured to trip if the average current of all three phases exceeds a specified level while the motor is running.

2-6 Instantaneous Overcurrent

Range:		Function:
400%*	[80% - 600% FLC]	Sets the trip point for instantaneous overcurrent protection, as a percentage of motor full load current.

2-7 Instantaneous Overcurrent Delay

Range:		Function:
0 secs*	[0:00 - 1:00 (min:secs)]	Slows the MCD 500's response to overcurrent, avoiding trips due to momentary overcurrent events.

7.5.4 Frequency Trip

The MCD 500 monitors mains frequency throughout operation, and can be configured to trip if the frequency varies beyond a specified tolerance.

2-8 Frequency Check

Option:	Function:
Do not Check	
Start Only	
Start/Run*	
Run Only	
	Determines when the starter will monitor for a frequency trip.

2-9 Frequency Variation

Option:	Function:
	Selects the soft starter's tolerance for frequency variation. Running a motor outside its specified frequency for long periods can cause damage and premature failure.
± 2 Hz	

2-9 Frequency Variation

Option:	Function:
± 5 Hz*	
± 10 Hz	
± 15 Hz	

2-10 Frequency Delay

Range:	Function:
1 sec* [0:01 - 4:00 (min:sec)]	Slows the MCD 500's response to frequency disturbances, avoiding trips due to momentary fluctuations. NOTE If the mains frequency drops below 35 Hz or rises above 75 Hz, the starter will trip immediately.

2-11 Restart Delay

Range:	Function:
10 secs* [00:01 - 60:00 (min:secs)]	The MCD 500 can be configured to force a delay between the end of a stop and the beginning of the next start. During the restart delay, the display shows the time remaining before another start can be attempted. NOTE The restart delay is measured from the end of each stop. Changes to the restart delay setting take effect immediately.

2-12 Motor Temperature Check

Option:	Function:
	Selects whether the MCD 500 will verify the motor has sufficient thermal capacity for a successful start. The soft starter compares the motor's calculated temperature with the temperature rise from the last motor start and only operates if the motor is cool enough to start successfully.
Do not Check*	
Check	

7.6 Inputs

3-1 Local/Remote

Option:	Function:
	Selects when the AUTO ON and HAND ON buttons can be used to switch to Hand On or Auto On modes.
Lcl/Rmt anytime*	The user can change between local and remote control at any time.
Local Control Only	All remote inputs are disabled.
Remote Control Only	Selects whether the starter can be used in Hand On or Auto On modes.

3-2 Comms in Remote

Option:	Function:
	Selects whether the starter will accept Start and Stop commands from the serial communication network when in Remote mode. The Force Comms Trip, Local/Remote Control and Test Start and Reset commands are always enabled.
Disable Ctrl in RMT	
Enable Ctrl in RMT*	

3-3 Input A Function

Option:	Function:
	Selects the function of Input A.
Motor Set Select*	The MCD 500 can be configured with two separate sets of motor data. The primary motor data is programmed using Par. 1-1 to 1-16. The secondary motor data is programmed using Par. 7-1 to 7-16. To use the secondary motor data, Par. 3-3 must be set to Motor Set Select and 11, 16 must be closed when a start command is given. The MCD 500 checks which motor data to use at a start, and will use that motor data for the entire start/stop cycle.
Input Trip (N/O)	Input A can be used to trip the soft starter. When Par. 3-3 is set to Input Trip (N/O), a closed circuit across 11, 16 trips the soft starter (Par. 3-5, 3-6, 3-7).
Input Trip (N/C)	When Par. 3-3 is set to Input Trip (N/C), an open circuit across 11, 16 trips the soft starter (Par. 3-5, 3-6, 3-7).
Local/Remote Select	Input A can be used to select between local and remote control, instead of using the buttons on the LCP. When the input is open, the starter is in local mode and can be controlled via the LCP. When the input is closed, the starter is in remote mode. The HAND ON and AUTO ON buttons are disabled, and the soft starter will ignore any Local/Remote select command from the serial communications network. To use Input A to select between local and remote control, Par. 3-1 must be set to LCL/RMT Anytime.
Emergency Run	In emergency run the soft starter continues to run until stopped, ignoring all trips and warnings (see Par. 15-3 for details). Closing the circuit across 11, 16 activates emergency run. Opening the circuit ends emergency run and the MCD 500 stops the motor.
Emergency Stop	The MCD 500 can be commanded to emergency stop the motor, ignoring the soft stop mode set in Par. 1-10. When the circuit across 11, 16 is opened, the soft starter allows the motor to coast to stop.

3-3 Input A Function

Option:	Function:
Jog Forward	Activates jog operation in a forward direction (will operate only in Remote mode).
Jog Reverse	Activates jog operation in reverse direction (will operate only in Remote mode).

3-4 Input A Name

Option:	Function:
	Selects a message for the LCP to display when Input A is active.
Input Trip*	
Low Pressure	
High Pressure	
Pump Fault	
Low Level	
High Level	
No Flow	
Emergency Stop	
Controller	
PLC	
Vibration Alarm	

3-5 Input A Trip

Option:	Function:
	Selects when an input trip can occur.
Always Active*	A trip can occur at any time when the soft starter is receiving power.
Operating Only	A trip can occur while the soft starter is running, stopping or starting.
Run Only	A trip can only occur while the soft starter is running.

3-6 Input A Trip Delay

Range:	Function:
0 secs* [0:00 - 4:00 (min:secs)]	Sets delay between the input activating and soft starter tripping.

3-7 Input A Initial Delay

Range:	Function:
0 secs* [00:00 - 30:00 (min:secs)]	Sets a delay before an input trip can occur. The initial delay is counted from the time a start signal is received. The state of the input is ignored until the initial delay has elapsed.

3-8 Remote Reset Logic

Option:	Function:
	Selects whether the MCD 500's remote reset input (terminals 25, 18) is normally open or normally closed.
Normally Closed*	
Normally Open	

7.7 Outputs

4-1 Relay A Function	
Option:	Function:
	Selects the function of Relay A (normally open).
Off	Relay A is not used
Main Contactor*	The relay closes when the MCD 500 receives a start command, and remains closed as long as the motor is receiving voltage.
Run	The relay closes when the starter changes to run state.
Trip	The relay closes when the starter trips.
Warning	The relay closes when the starter issues a warning.
Low Current Flag	The relay closes when the low current flag activates (Par. 4-10 <i>Low Current Flag</i>).
High Current Flag	The relay closes when the high current flag activates (Par. 4-11 <i>High Current Flag</i>).
Motor Temp Flag	The relay closes when the motor temperature flag activates (Par. 4-12 <i>Motor Temperature Flag</i>).

7.7.1 Relay A Delays

The MCD 500 can be configured to wait before opening or closing Relay A.

4-2 Relay A On Delay		
Range:		Function:
0 secs*	[0:00 - 5:00 (min:secs)]	Sets the delay for closing Relay A.

4-3 Relay A Off Delay		
Range:		Function:
0 secs*	[0:00 - 5:00 (min:secs)]	Sets the delay for re-opening Relay A.

7.7.2 Relays B and C

Parameters 4-4 to 4-9 configure the operation of Relays B and C in the same way as parameters 4-1 to 4-3 configure Relay A.

4-4 Relay B Function	
Option:	Function:
	Selects the function of Relay B (changeover).
Off	Relay B is not used
Main Contactor	The relay closes when the MCD 500 receives a start command, and remains closed as long as the motor is receiving voltage.
Run*	The relay closes when the starter changes to run state.
Trip	The relay closes when the starter trips.
Warning	The relay closes when the starter issues a warning.

4-4 Relay B Function	
Option:	Function:
Low Current Flag	The relay closes when the low current flag activates (Par. 4-10 <i>Low Current Flag</i>).
High Current Flag	The relay closes when the high current flag activates (Par. 4-11 <i>High Current Flag</i>).
Motor Temp Flag	The relay closes when the motor temperature flag activates (Par. 4-12 <i>Motor Temperature Flag</i>).

4-5 Relay B On Delay		
Range:		Function:
0 secs*	[0:00 - 5:00 (min:secs)]	Sets the delay for closing Relay B.

4-6 Relay B Off Delay		
Range:		Function:
0 secs*	[0:00 - 5:00 (min:secs)]	Sets the delay for re-opening Relay B.

4-7 Relay C Function	
Option:	Function:
	Selects the function of Relay C (normally open).
Off	Relay C is not used
Main Contactor	The relay closes when the MCD 500 receives a start command, and remains closed as long as the motor is receiving voltage.
Run	The relay closes when the starter changes to run state.
Trip*	The relay closes when the starter trips.
Warning	The relay closes when the starter issues a warning.
Low Current Flag	The relay closes when the low current flag activates (Par. 4-10 <i>Low Current Flag</i>).
High Current Flag	The relay closes when the high current flag activates (Par. 4-11 <i>High Current Flag</i>).
Motor Temp Flag	The relay closes when the motor temperature flag activates (Par. 4-12 <i>Motor Temperature Flag</i>).

4-8 Relay C On Delay		
Range:		Function:
0 secs*	[0:00 - 5:00 (min:secs)]	Sets the delay for closing Relay C.

4-9 Relay C Off Delay		
Range:		Function:
0 secs*	[0:00 - 5:00 (min:secs)]	Sets the delay for re-opening Relay C.

7.7.3 Low Current Flag and High Current Flag

The MCD 500 has low and high current flags to give early warning of abnormal operation. The current flags can be configured to indicate an abnormal current level during operation, between the normal operating level and the

undercurrent or instantaneous overcurrent trip levels. The flags can signal the situation to external equipment via one of the programmable outputs. The flags clear when the current returns within the normal operating range by 10% of the programmed motor full load current.

4-10 Low Current Flag

Range:	Function:
50%* [1% - 100% FLC]	Sets the level at which the low current flag operates, as a percentage of motor full load current.

4-11 High Current Flag

Range:	Function:
100%* [50% - 600% FLC]	Sets the level at which the high current flag operates, as a percentage of motor full load current.

7.7.4 Motor Temperature Flag

The MCD 500 has a motor temperature flag to give early warning of abnormal operation. The flag can indicate that the motor is operating above its normal operating temperature, but lower than the overload limit. The flag can signal the situation to external equipment via one of the programmable outputs.

4-12 Motor Temperature Flag

Range:	Function:
80%* [0% - 160%]	Sets the level at which the motor temperature flag operates, as a percentage of the motor's thermal capacity.

7.7.5 Analog Output A

The MCD 500 has an analog output, which can be connected to associated equipment to monitor motor performance.

4-13 Analog Output A

Option:	Function:
	Selects which information will be reported via analog output A.
Current (% FLC)*	Current as a percentage of motor full load current.
Motor Temp (%)	Motor temperature as a percentage of the motor service factor (calculated by the soft starter's thermal model).
Motor kW (%)	Motor kilowatts. 100% is motor FLC (Par. 1-1) multiplied by mains reference voltage (Par. 8-9). Power factor is assumed to be 1.0. $\frac{\sqrt{3} \times V \times I_{FLC} \times pf}{1000}$
Motor kVA (%)	Motor kilovolt amperes. 100% is motor FLC (Par. 1-1) multiplied by mains reference voltage (Par. 8-9).

4-13 Analog Output A

Option:	Function:
	$\frac{\sqrt{3} \times V \times I_{FLC}}{1000}$
Motor pf	Motor power factor, measured by the soft starter.

4-14 Analog A Scale

Option:	Function:
	Selects the range of the output.
0-20 mA	
4-20 mA*	

4-15 Analog A Maximum Adjustment

Range:	Function:
100%* [0% - 600%]	Calibrates the upper limit of the analog output to match the signal measured on an external current measuring device.

4-16 Analog A Minimum Adjustment

Range:	Function:
0%* [0% - 600%]	Calibrates the lower limit of the analog output to match the signal measured on an external current measuring device.

7.8 Start/Stop Timers

CAUTION

The auto-start timer overrides any other form of control. The motor may start without warning.

5-1 Auto-Start Type

Option:	Function:
	Selects whether the soft starter will auto-start after a specified delay, or at a time of day.
Off*	The soft starter will not auto-start.
Timer	The soft starter will auto-start after a delay from the next stop, as specified in Par. 5-2.
Clock	The soft starter will auto-start at the time programmed in Par. 5-2.

5-2 Auto-Start Time

Range:	Function:
1 min* [00:01 - 24:00 (hrs:min)]	Sets the time for the soft starter to auto-start, in 24 hour clock format.

5-3 Auto-Stop Type

Option:	Function:
	Selects whether the soft starter will auto-stop after a specified delay, or at a time of day.
Off*	The soft starter will not auto-stop.
Time	The soft starter will auto-stop after a delay from the next start, as specified in Par. 5-4.
Clock	The soft starter will auto-stop at the time programmed in Par. 5-4.

5-4 Auto-Stop Time

Range:	Function:
1 min* [00:01 - 24:00 (hrs:min)]	Sets the time for the soft starter to auto-stop, in 24 hour clock format.

CAUTION
This function should not be used in conjunction with remote two-wire control. The soft starter will still accept start and stop commands from the remote inputs or serial communication network. To disable local or remote control, use Par. 3-1 Local/Remote. If auto-start is enabled and the user is in the menu system, auto-start will become active if the menu times out (if no keypad activity is detected for five minutes).

7.9 Auto-Reset

The MCD 500 can be programmed to automatically reset certain trips, which can help minimise operating downtime. Trips are divided into three categories for auto-reset, depending on the risk to the soft starter:

Group	
A	Current Imbalance
	Phase Loss
	Power Loss
	Mains Frequency
B	Undercurrent
	Instantaneous Overcurrent
	Input A Trip
C	Motor Overload
	Motor Thermistor
	Starter Overtemperature

Other trips cannot be automatically reset.

This function is ideal for remote installations using 2-wire control in Auto On mode. If the 2-wire start signal is present after an auto-reset, the MCD 500 will restart.

6-1 Auto-Reset Action

Option:	Function:
	Selects which trips can be auto-reset.
Do not Auto-Reset*	
Reset Group A	
Reset Group A & B	
Reset Group A, B & C	

6-2 Maximum Resets

Range:	Function:
1* [1 - 5]	Sets how many times the soft starter will auto-reset, if it continues to trip. The reset counter increases by one each time the soft starter auto-resets, and

6-2 Maximum Resets

Range:	Function:
	decreases by one after each successful start/stop cycle.

NOTE

The reset counter will return to 0 if the starter is manually reset.

7.9.1 Auto-Reset Delay

The MCD 500 can be configured to wait before auto-resetting a trip. Separate delays can be set for trips in Groups A and B, or in Group C.

6-3 Reset Delay Groups A & B

Range:	Function:
5 secs* [00:05 - 15:00 (min:secs)]	Sets the auto-reset delay for Group A and Group B trips.

6-4 Reset Delay Group C

Range:	Function:
5 min* [5 - 60 (minutes)]	Sets the auto-reset delay for Group C trips.

7.10 Secondary Motor Set

7-1 Motor FLC-2

Range:	Function:
[Motor dependent]	Matches the starter to the second motor's full load current. Set to the full load current (FLC) rating shown on the motor nameplate.

7-2 Locked Rotor Time-2

Range:	Function:
10 secs* [0:01 - 2:00 (min:secs)]	Sets the maximum length of the time the motor can run at locked rotor current from cold before reaching its maximum temperature. Set according to the motor datasheet. If this information is not available, we recommend the value should be less than 20 seconds.

7-3 Start Mode-2

Option:	Function:
	Selects the start mode for the secondary motor.
Constant Current*	
Adaptive Control	

7-4 Current Limit-2

Range:	Function:
350%* [100% - 600% FLC]	Sets the current limit for constant current and current ramp soft starting, as a percentage of motor full load current.



7-5 Initial Current-2

Range:	Function:
350%* [100% - 600% FLC]	Sets the initial start current level for current ramp starting, as a percentage of motor full load current. Set so that the motor begins to accelerate immediately after a start is initiated. If current ramp starting is not required, set the initial current equal to the current limit.

7-6 Start Ramp Time-2

Range:	Function:
10 secs* [1 - 180 secs]	Sets the total start time for an AAC Adaptive Control start or the ramp time for current ramp starting (from the initial current to the current limit).

7-7 Kickstart Level-2

Range:	Function:
500%* [100% - 700% FLC]	Sets the level of the kickstart current.

7-8 Kickstart Time-2

Range:	Function:
0000 msec* [0 - 2000 msec]	Sets the kickstart duration. A setting of 0 disables kickstart.

7-9 Excess Start Time-2

Range:	Function:
	Excess start time is the maximum time the MCD 500 will attempt to start the motor. If the motor does not reach full speed within the programmed limit, the starter will trip. Set for a period slightly longer than required for a normal healthy start. A setting of 0 disables excess start time protection.
20 sec* [0:00 - 4:00 (min:secs)]	Set the excess time for the secondary motor.

7-10 Stop Mode-2

Option:	Function:
	Selects the stop mode for the secondary motor.
Coast to Stop*	
TVR Soft Stop	
Adaptive Control	
Brake	

7-11 Stop Time-2

Range:	Function:
0 sec* [0:00 - 4:00 (min:secs)]	Sets the time for soft stopping the motor using timed voltage ramp or Adaptive Control (AAC). If a main contactor is installed, the contactor must remain closed until the end of the stop time. Use a programmable output configured to Run

7-11 Stop Time-2

Range:	Function:
	to control the main contactor. Sets the total stopping time when using brake.

7-12 Adaptive Control Gain-2

Range:	Function:
75%* [1% - 200%]	Adjusts the performance of AAC adaptive acceleration control. NOTE We recommend leaving the gain setting at the default level unless AAC performance is not satisfactory. If the motor accelerates or decelerates quickly at the end of a start or stop, increase the gain by setting by 5% - 10%. If the motor speed fluctuates during starting or stopping, decrease the gain setting slightly.

7-13 Adaptive Start Profile-2

Option:	Function:
	Selects which profile the MCD 500 will use for an AAC adaptive acceleration control soft start.
Early Acceleration	
Constant Acceleration*	
Late Acceleration	

7-14 Adaptive Stop Profile-2

Option:	Function:
	Selects which profile the MCD 500 will use for an AAC adaptive acceleration control soft stop.
Early Deceleration	
Constant Deceleration*	
Late Acceleration	

7-15 Brake Torque-2

Range:	Function:
20%* [20 - 100%]	Sets the amount of brake torque the MCD 500 will use to slow the motor.

7-16 Brake Time-2

Range:	Function:
1 sec* [1 - 30 sec]	Sets the duration for DC injection during a braking stop. NOTE Parameter 7-16 is used in conjunction with Par. 7-11.

7.11 Display

8-1 Language	
Option:	Function:
	Selects which language the LCP will use to display messages and feedback.
English*	
Chinese (中文)	
Spanish (Español)	
German (Deutsch)	
Portuguese (Português)	
French (Français)	
Italian (Italiano)	
Russian (Русский)	

7.11.1 User Programmable Screen

Selects which four items will be displayed on the programmable monitoring screen.

8-2 User Screen - Top Left	
Option:	Function:
	Selects the item displayed in the top left part of the screen.
Blank	Displays no data in the selected area, allowing long messages to be shown without overlapping.
Starter State	The starter's operating state (starting, running, stopping or tripped). Only available for "Top L" and "Btm L".
Motor Current	The average current measured on three phases.
Motor pf*	The motor's power factor, measured by the soft starter.
Mains Frequency	The average frequency measured on three phases.
Motor kW	The motor's running power in kilowatts.
Motor HP	The motor's running power in horsepower.
Motor Temp	The motor's temperature, calculated by the thermal model.
kWh	The number of kilowatt hours the motor has run via the soft starter.
Hours Run	The number of hours the motor has run via the soft starter.

8-3 User Screen - Top Right	
Option:	Function:
	Selects the item displayed in the top right part of the screen.
Blank*	Displays no data in the selected area, allowing long messages to be shown without overlapping.
Starter State	The starter's operating state (starting, running, stopping or tripped). Only available for "Top L" and "Btm L".

8-3 User Screen - Top Right	
Option:	Function:
Motor Current	The average current measured on three phases.
Motor pf	The motor's power factor, measured by the soft starter.
Mains Frequency	The average frequency measured on three phases.
Motor kW	The motor's running power in kilowatts.
Motor HP	The motor's running power in horsepower.
Motor Temp	The motor's temperature, calculated by the thermal model.
kWh	The number of kilowatt hours the motor has run via the soft starter.
Hours Run	The number of hours the motor has run via the soft starter.

8-4 User Screen - Bottom Left	
Option:	Function:
	Selects the item displayed in the bottom left part of the screen.
Blank	Displays no data in the selected area, allowing long messages to be shown without overlapping.
Starter State	The starter's operating state (starting, running, stopping or tripped). Only available for "Top L" and "Btm L".
Motor Current	The average current measured on three phases.
Motor pf	The motor's power factor, measured by the soft starter.
Mains Frequency	The average frequency measured on three phases.
Motor kW	The motor's running power in kilowatts.
Motor HP	The motor's running power in horsepower.
Motor Temp	The motor's temperature, calculated by the thermal model.
kWh	The number of kilowatt hours the motor has run via the soft starter.
Hours Run*	The number of hours the motor has run via the soft starter.

8-5 User Screen - Bottom Right	
Option:	Function:
	Selects the item displayed in the bottom right part of the screen.
Blank*	Displays no data in the selected area, allowing long messages to be shown without overlapping.
Starter State	The starter's operating state (starting, running, stopping or tripped). Only available for "Top L" and "Btm L".
Motor Current	The average current measured on three phases.
Motor pf	The motor's power factor, measured by the soft starter.

7

8-5 User Screen - Bottom Right

Option:	Function:
Mains Frequency	The average frequency measured on three phases.
Motor kW	The motor's running power in kilowatts.
Motor HP	The motor's running power in horsepower.
Motor Temp	The motor's temperature, calculated by the thermal model.
kWh	The number of kilowatt hours the motor has run via the soft starter.
Hours Run	The number of hours the motor has run via the soft starter.

7.11.2 Performance Graphs

The loggings menu allows the user to view performance information in real-time graphs.

The newest information is displayed at the right hand edge of the screen. The graph can be paused to analyse data by pressing and holding the OK button. To re-start the graph, press and hold OK.

8-6 Graph Timebase

Option:	Function:
	Sets the graph time scale. The graph will progressively replace the old data with new data.
10 secs*	
30 secs	
1 min	
5 minutes	
10 minutes	
30 minutes	
1 hour	

8-7 Graph Maximum Adjustment

Range:	Function:
400%* [0% - 600%]	Adjusts the upper limit of the performance graph

8-8 Graph Minimum Adjustment

Range:	Function:
0%* [0% - 600%]	Adjusts the lower limit of the performance graph.

8-9 Mains Reference Voltage

Range:	Function:
400 V* [100 - 690 V]	Sets the nominal voltage for the LCP's monitoring functions. This is used to calculate motor kilowatts and kilovolt amperes (kVA), but does not affect the MCD 500's motor control protection. Enter the measured mains voltage.

7.12 Restricted Parameters

15-1 Access Code

Range:	Function:
0000* [0000 - 9999]	<p>Sets the access code to enter the simulation tools and counter resets or the restricted section of the Programming Menu (parameter group 15 and higher).</p> <p>Use the BACK and OK buttons to select which digit to alter and use the ▲ and ▼ buttons to change the value.</p> <p>NOTE In the event of a lost access code, contact your supplier for master access code that allows you to re-program a new access code.</p>

15-2 Adjustment Lock

Option:	Function:
	Selects whether the LCP will allow parameters to be changed via the Programming Menu.
Read & Write*	Allows users to alter parameter values in the Programming Menu
Read Only	Prevents users altering parameter values in the Programming Menu. Parameter values can still be viewed.
No Access	Prevents users adjusting parameters in the Programming Menu unless an access code is entered.
	<p>NOTE Changes to the Adjustment Lock setting take effect only after the Programming Menu has been closed.</p>

15-3 Emergency Run

Option:	Function:
	<p>Selects whether the soft starter will permit emergency run operation. In emergency run, the soft starter will start (if not already running) and continue to operate until emergency run ends, ignoring stop commands and trips. Emergency run is controlled using a programmable input. When Emergency Run is activated in internally bypassed models which are not running, the starter will attempt a normal start while ignoring all trips. If a normal start is not possible, a DOL start via the internal bypass relays will be attempted. For non-bypassed models, an external emergency run bypass contactor may be used.</p>

15-4 Current Calibration

Range:	Function:
100%* [85% - 115%]	<p>Motor Current Calibration calibrates the soft starter's current monitoring circuits to match an external current metering device.</p> <p>Use the following formula to determine the necessary adjustment:</p>

15-4 Current Calibration	
Range:	Function:
	$\text{Calibration (\%)} = \frac{\text{Current shown on MCD 500 display}}{\text{Current measured by external device}}$ <p>e.g. 102% = $\frac{66\text{ A}}{65\text{ A}}$</p> <p>NOTE This adjustment affects all current-based functions.</p>

15-5 Main Contactor Time	
Range:	Function:
150 msec* msec*]	[100 - 2000 msec] Sets the delay period between the starter switching the main contactor output (terminals 13, 14) and beginning the pre-start checks (before start) or entering the not ready state (after a stop). Set according to the specifications of the main contactor used.

15-6 Bypass Contactor Time	
Range:	Function:
150 msec* msec*]	[100 - 2000 msec] Sets the starter to match the bypass contactor closing time. Set according to the specifications of the bypass contactor used. If the time is too short, the starter will trip.

15-7 Motor Connection	
Option:	Function:
	Selects the soft starter will automatically detect the format of the connection to the motor.
Auto-Detect*	
In-line	
Inside Delta	

15-8 Jog Torque	
Range:	Function:
50%*]	[20% - 100%] Sets the torque level for jog operation. See the section <i>Jog Operation</i> for more details.

NOTE

Setting Par. 15-8 above 50% may cause increased shaft vibration.

7.13 Protection Action

16-1 - 16-12 Protection Action	
Option:	Function:
	Selects the soft starter's response to each protection. <ul style="list-style-type: none"> • 16-1 Motor Overload • 16-2 Current Imbalance • 16-3 Undercurrent • 16-4 Inst Overcurrent

16-1 - 16-12 Protection Action	
Option:	Function:
	<ul style="list-style-type: none"> • 16-5 Frequency • 16-6 Heatsink Overtemp • 16-7 Excess Start Time • 16-8 Input A Trip • 16-9 Motor Thermistor • 16-10 Starter/Comms • 16-11 Network/Comms • 16-12 Battery/Clock
Trip Starter*	
Warn and Log	
Log Only	

7.14 Factory Parameters

These parameters are restricted for Factory use and are not available to the user.

8 Tools

To access Tools, open the Main Menu, scroll to Tools and press **OK**.

8.1 Set Date and Time

To set the date and time:

1. Open the Tools Menu.
2. Scroll to *Set Date & Time*.
3. Press the **OK** button to enter edit mode.
4. Press the **OK** button to select which part of the date or time to edit.
5. Use the **▲** and **▼** buttons to change the value.

To save changes, press the **OK** button repeatedly. The MCD 500 will confirm the changes. To cancel changes, press the **BACK** button repeatedly.

8.2 Load/Save Settings

The MCD 500 includes options to:

- Load defaults: Load the MCD 500's parameters with default values
- Load User Set 1: Reload previously saved parameter settings from an internal file
- Save User Set 1: Save the current parameter settings to an internal file

In addition to the factory default values file, the MCD 500 can store a user-defined parameter file. This file contains default values until a user file is saved.

To load or save parameter settings:

1. Open the Tools Menu.
2. Use the **▼** button to select the required function, then press the **OK** button.
3. At the confirmation prompt, select YES to confirm or NO to cancel and then **OK** to load/save the selection or exit the screen.

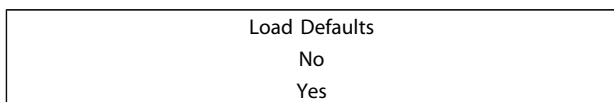
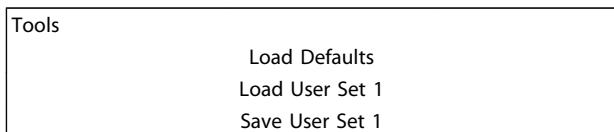

When the action has been completed, the screen will briefly display a confirmation message, then return to the status screens.

8.3 Reset Thermal Model

NOTE

This function is protected by the security access code.

The MCD 500's advanced thermal modelling software constantly monitors the motor's performance. This allows the MCD 500 to calculate the motor's temperature and ability to start successfully at any time.

The thermal model can be reset if required.

1. Open Tools.
2. Scroll to Reset Thermal Model and press **OK**.
3. At the confirmation prompt, press **OK** to confirm then enter the access code, or press **Back** to cancel the action.
4. Select Reset or Do Not Reset, then press **OK**. When the thermal model has been reset, the MCD 500 will return to the previous screen.

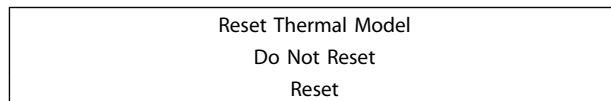
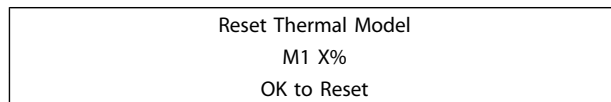

CAUTION

Adjusting the motor thermal model may compromise motor life and should only be done in the case of emergency.

8.4 Protection Simulation

NOTE

This function is protected by the security access code.

Software simulation functions let you test the soft starter's operation and control circuits without connecting the soft starter to mains voltage.

The MCD 500 can simulate each different protection, in order to confirm that the soft starter is responding correctly and reporting the situation on the display and across the communication network.

To use the protection simulation:

1. Open the Main Menu.
2. Scroll to Protection Sim and press **OK**.
3. Use the ▲ and ▼ buttons to select the protection you want to simulate.
4. Press **OK** to simulate the selected protection.
5. The protection message is displayed while **OK** is pressed. The soft starter's response depends on the Protection Action setting (parameter group 16).
6. Press **BACK** to return to the simulation list.
7. Use ▲ or ▼ to select another simulation, or press **BACK** to return to the Main Menu.

MS1	000.0A	0000.0kW
Tripped		
Selected Protection		

NOTE

If the protection trips the soft starter, reset before simulating another protection. If the protection action is set to 'Warn or Log', no reset is required.

If the protection is set to 'Warn & Log', the warning message can be viewed only while the 'OK' button is pressed.

If the protection is set to 'Log only', nothing appears on the screen but an entry will appear in the log.

8.5 Output Signal Simulation

NOTE

This function is protected by the security access code.

The top line of the screen shows the start, stop, reset and programmable input.

The bottom line of the screen shows programmable outputs A, B and C.

The screen shot shows the stop input (17) as closed (1) and the start, reset and Input A inputs (15, 25, 11) as open (0). Relay A (13, 14) is closed and relays B and C (21, 22, 24 and 33, 34) are open,

Digital I/O State	
Inputs: 0100	
Outputs: 100	

8.7 Temp Sensors State

This screen shows the state of the motor thermistor. The screen shot shows the thermistor state as O (open).

The LCP allows the user to simulate output signalling in order to confirm that the output relays are operating correctly.

NOTE

To test operation of the flags (motor temperature and low/high current), set an output relay to the appropriate function and monitor the relay's behaviour.

To use the output signal simulation:

1. Open the Main Menu.
2. Scroll to Output Signal Sim and press **OK**, then enter the access code.
3. Use the ▲ and ▼ buttons to select a simulation, then press **OK**.
4. Use the ▲ and ▼ buttons to turn the signal on and off. To confirm correct operation, monitor the state of the output.
5. Press **BACK** to return to the simulation list.

Prog Relay A	
Off	
On	

8.6 Digital I/O State

This screen shows the current status of the Digital I/O in order.

Temp Sensors State	
Thermistor: O	
S = shrt H=hot C=cld O=opn	

8.8 Alarm Log

The **Alarm Log** button opens the Alarm Logs, which contains a Trip Log, Event Log, and Counters which store information on the MCD 500's operating history.

8.8.1 Trip Log

The Trip Log stores details of the eight most recent trips, including the date and time the trip happened. Trip 1 is the most recent and trip 8 is the oldest stored trip.

To open the Trip Log:

1. Open the Alarm Logs.
2. Scroll to Trip Log and press **OK**.
3. Use the ▲ and ▼ buttons to select a trip to view, and press **OK** to display details.

To close the log and return to the main display, press **BACK**.

8.8.2 Event Log

The Event Log stores time-stamped details of the starter's 99 most recent events (actions, warnings and trips), including the date and time of the event. Event 1 is the most recent and event 99 is the oldest stored event.

To open the Event Log:

1. Open the Alarm Logs.
2. Scroll to Event Log and press **OK**.
3. Use the ▲ and ▼ buttons to select an event to view, and press **OK** to display details.

To close the log and return to the main display, press **BACK**.

8.8.3 Counters

NOTE

This function is protected by the security access code.

The performance counters store statistics on the starter's operation:

- Hours run (lifetime and since counter last reset)
- Number of starts (lifetime and since counter last reset)
- Motor kWh (lifetime and since counter last reset)
- Number of times the thermal model has been reset

The resettable counters (hours run, starts and motor kWh) can only be reset if the correct access code is entered.

To view the counters:

1. Open the Alarm Logs.
2. Scroll to Counters and press **OK**.
3. Use the ▲ and ▼ buttons to scroll through the counters. Press **OK** to view details.
4. To reset a counter, press **OK** then enter the access code. Select Reset, then press **OK** to confirm.

To close the counter and return to the Alarm Logs, press **BACK**.

9 Troubleshooting

When a protection condition is detected, the MCD 500 will write this to the event log and may also trip or issue a warning. The soft starter's response to some protections may depend on the Protection Action settings (parameter group 16).

If the MCD 500 trips you will need to reset the soft starter before restarting. If the MCD 500 has issued a warning, the soft starter will reset itself once the cause of the warning has been resolved.

Some protections cause a fatal trip. This response is pre-defined and cannot be overridden. These protection

mechanisms are designed to protect the soft starter, or can be caused by a fault within the soft starter.

9.1 Trip Messages

This table lists soft starter's protection mechanisms and the probable cause of the trip. Some of these can be adjusted using parameter group 2 *Protection* and parameter group 16 *Protection Action*, other settings are built-in system protections and cannot be set or adjusted.

Display	Possible cause/Suggested solution
Battery/Clock	A verification error has occurred on the real time clock, or the backup battery voltage is low. If the battery is low and the power is off, date/time settings will be lost. Reprogram the date and time. Related Pars.: 16-12
Current Imbalance	Current imbalance can be caused by problems with the motor, the environment or the installation, such as: <ul style="list-style-type: none"> - An imbalance in the incoming mains voltage - A problem with the motor windings - A light load on the motor Current imbalance can also be caused by incorrect cabling between the external bypass contactor and the soft starter or an internal problem with the soft starter, particularly an SCR that has failed open circuit. A failed SCR can only be definitely diagnosed by replacing the SCR and checking the starter's performance. Related Pars.: 2-2, 2-3, 16-2
Excess Start Time	Excess start time trip can occur in the following conditions: <ul style="list-style-type: none"> • 1-1 <i>Motor Full Load Current</i> is not appropriate for the motor • 1-4 <i>Current Limit</i> • 1-6 <i>Start Ramp Time</i> has been set greater than the setting for 1-9 <i>Excess Start Time Setting</i> • 1-6 <i>Start Ramp Time</i> is set too short for a high inertia load when using Adaptive Acceleration Control Related Pars.: 1-1, 1-6, 1-4, 1-9, 7-9, 7-1, 7-6, 7-4, 16-7
FLC Too High	The MCD 500 can support higher motor FLC values when connected to the motor using inside delta configuration rather than in-line connection. If the soft starter is connected in-line but the programmed setting for 1-1 <i>Motor Full Load Current</i> is above the in-line maximum, the soft starter will trip at start. Related Pars.: 1-1, 7-1
Frequency	The mains frequency has gone beyond the specified range. Check for other equipment in the area that could be affecting the mains supply (particularly variable speed drives). If the MCD 500 is connected to a generator set supply, the generator may be too small or could have a speed regulation problem. Related Pars.: 2-8, 2-9, 2-10, 16-5

Display	Possible cause/Suggested solution
Heatsink Overtemp	<p>Check if cooling fans are operating. If mounted in an enclosure, check if ventilation is adequate. Fans operate during Start, Run and for 10 minutes after the starter exits the Stop state.</p> <p>NOTE Models MCD5-0021B to MCD4-0053B and MCD5-0141B do not have a cooling fan. Models without internal bypass will operate the cooling fans from a Start until 10 minutes after a Stop.</p> <p>Related Pars.: 16-6</p>
Input A Trip	<p>Identify and resolve the condition which caused Input A to activate.</p> <p>Related Pars.: 3-3, 3-4, 3-5, 3-6, 3-7, 16-8</p>
Inst Overcurrent	<p>The motor has experienced a sharp rise in motor current, probably caused by a locked rotor condition (shearpin) while running. This may indicate a jammed load.</p> <p>Related Pars.: 2-6, 2-7, 16-4</p>
Internal Fault X	<p>The MCD 500 has tripped on an internal fault. Contact your local supplier with the fault code (X).</p> <p>Related Pars.: None</p>
L1 Phase Loss L2 Phase Loss L3 Phase Loss	<p>During prestart checks the starter has detected a phase loss as indicated.</p> <p>In run state, the starter has detected that the current on the affected phase has dropped below 3.3% of the programmed motor FLC for more than 1 second, indicating that either the incoming phase or connection to the motor has been lost.</p> <p>Check the supply and the input and output connections at the starter and at the motor end. Phase loss can also be caused by a failed SCR, particularly an SCR that has failed open circuit. A failed SCR can only be definitely diagnosed by replacing the SCR and checking the starter's performance.</p> <p>Related Pars.: None</p>
L1-T1 Shorted L2-T2 Shorted L3-T3 Shorted	<p>During prestart checks the starter has detected a shorted SCR or a short within the bypass contactor as indicated.</p> <p>Related Pars.: none</p>
Low Control Volts	<p>The internal 24 VDC rail has dropped below 19V. This may have been caused by a fluctuation of the control supply. Reset the trip. If the problem persists:</p> <ul style="list-style-type: none"> • The 24 V supply in the main control PCB may be faulty; or • the bypass driver PCB may be faulty (internally bypassed models only). <p>These trips cannot be reset. Contact your local supplier for advice.</p> <p>Related Pars: None</p>
Motor Overload/ Motor 2 Overload	<p>The motor has reached its maximum thermal capacity. Overload can be caused by:</p> <ul style="list-style-type: none"> - The soft starter protection settings not matching the motor thermal capacity. - Excessive starts per hour - Excessive throughput - Damage to the motor windings. <p>Resolve the cause of the overload and allow the motor to cool.</p> <p>Related Pars.: 1-1, 1-2, 1-3, 1-4, 7-1, 7-2, 7-3, 7-4, 16-1</p>
Motor Connection	<p>The motor is not connected correctly to the soft starter for inline or inside delta use.</p> <ul style="list-style-type: none"> - Check individual motor connections to the soft starter for power circuit continuity. - Check connections at the motor terminal box. <p>Related Pars.: 15-7</p>

Display	Possible cause/Suggested solution
Motor Thermistor	<p>The motor thermistor input has been enabled and:</p> <ul style="list-style-type: none"> - The resistance at the thermistor input has exceeded 3.6 kΩ for more than one second. - The motor winding has overheated. Identify the cause of the overheating and allow the motor to cool before restarting. - The motor thermistor input has been open. <p>NOTE If a valid motor thermistor is no longer used, a 1.2 kΩ resistor must be fitted across terminals 05, 06.</p> <p>Related Pars.: 16-9</p>
Network Comms	<p>The network master has sent a trip command to the starter, or there may be a network communication problem.</p> <p>Check the network for causes of communication inactivity.</p> <p>Related Pars.: 16-11</p>
Parameter out of Range	<ul style="list-style-type: none"> - A parameter value is outside the valid range. <p>The starter will load the default value for all affected parameters. Press MAIN MENU to go to the first invalid parameter and adjust the setting.</p> <p>Related Pars.: None</p>
Phase Sequence	<p>The phase sequence on the soft starter's input terminals (L1, L2, L3) is not valid.</p> <p>Check the phase sequence on L1, L2, L3 and ensure the setting in Par. 2-1 is suitable for the installation.</p> <p>Related Pars.: 2-1</p>
Power Loss	<p>The starter is not receiving mains supply on one or more phases when a Start Command is given.</p> <p>Check that the main contactor closes when a start command is given, and remains closed until the end of a soft stop.</p> <p>Related Pars.: 15-5</p>
Starter/Comms	<ul style="list-style-type: none"> - There is a problem with the connection between the soft starter and the optional communications module. Remove and reinstall the module. If the problem persists, contact your local distributor. - There is an internal communications error within the soft starter. Contact your local distributor. <p>Related Pars.: 16-10</p>
Thermistor Cct	<p>The thermistor input has been enabled and:</p> <ul style="list-style-type: none"> - The resistance at the input has fallen below 20 Ω (the cold resistance of most thermistors will be over this value) or - A short circuit has occurred. Check and resolve this condition. <p>Check that a PT100 (RTD) is not connected to 05, 06.</p> <p>Related Pars.: None.</p>
Time - Overcurrent	<p>The MCD 500 is internally bypassed and has drawn high current during running. (The 10A protection curve trip has been reached or the motor current has risen to 600% of the motor FLC setting.)</p> <p>Related Pars.: None</p>
Undercurrent	<p>The motor has experienced a sharp drop in current, caused by loss of load. Causes can include broken components (shafts, belts or couplings), or a pump running dry.</p> <p>Related Pars.: 2-4, 2-5, 16-3</p>
Unsupported Option	<p>The selected function is not available (e.g. jog is not supported in inside delta configuration).</p> <p>Related Pars.: None</p>

9.2 General Faults

This table describes situations where the soft starter does not operate as expected but does not trip or give a warning.

Symptom	Probable Cause
Soft starter does not respond to commands.	<ul style="list-style-type: none"> - If the soft starter does not respond to the RESET button on the LCP: The soft starter may be in Auto On mode and will only accept commands from the remote control inputs. In Auto On mode, the Auto On LED on the LCP is active. Press the Hand On or Off button to enable control via the LCP (this will also send a start or stop command to the MCD 500). - If the soft starter does not respond to commands from the control inputs: The soft starter may be in Hand On mode and will only accept commands from the LCP. When the soft starter is in Hand On control mode, the Off or Hand On LED on the LCP is active. To change to Auto On mode, press the Auto On button once. The control wiring may be incorrect. Check that the remote start, stop and reset inputs are configured correctly (see <i>Control Wiring</i> for details). The signals to the remote inputs may be incorrect. Test the signalling by activating each input signal in turn. The appropriate remote control input LED should activate on the LCP. The soft starter will only execute a start command from the remote inputs if the remote stop input is inactive and the remote reset input is activated (the Reset LED on the starter will be on). - If the soft starter does not respond to a start command from either the local or remote controls: The soft starter may be waiting for the restart delay to elapse. The length of the restart delay is controlled by Par. 2-11 <i>Restart Delay</i>. The motor may be too hot to permit a start. If Par. 2-12 <i>Motor Temperature Check</i> is set to Check, the soft starter will only permit a start when it calculates that the motor has sufficient thermal capacity to complete the start successfully. Wait for the motor to cool before attempting another start. The emergency stop function may be active. If Par. 3-3 is set to Emergency Stop and there is an open circuit on the corresponding input, the MCD 500 will not start. If the emergency stop situation has been resolved, close the circuit on the input.
The soft starter does not control the motor correctly during starting.	<ul style="list-style-type: none"> - Start performance may be unstable when using a low Motor Full Load Current setting (Par. 1-1). This can affect use on a small test motor with full load current between 5 A and 50 A. - Power factor correction (PFC) capacitors must be installed on the supply side of the soft starter. To control a dedicated PFC capacitor contactor, connect the contactor to run relay terminals.
Motor does not reach full speed.	<ul style="list-style-type: none"> - If the start current is too low, the motor will not produce enough torque to accelerate to full speed. The soft starter may trip on excess start time. <p>NOTE Make sure the motor starting parameters are appropriate for the application and that you are using the intended motor starting profile. If Par. 3-3 is set to Motor Set Select, check that the corresponding input is in the expected state.</p> <ul style="list-style-type: none"> - The load may be jammed. Check the load for severe overloading or a locked rotor situation.
Erratic motor operation.	<ul style="list-style-type: none"> - The SCRs in the MCD 500 require at least 5 A of current to latch. If you are testing the soft starter on a motor with full load current less than 5 A, the SCRs may not latch correctly.
Soft stop ends too quickly.	<ul style="list-style-type: none"> - The soft stop settings may not be appropriate for the motor and load. Review the settings of Pars. 1-10, 1-11, 7-10 and 7-11. - If the motor is very lightly loaded, soft stop will have limited effect.

Symptom	Probable Cause
AAC adaptive acceleration control, DC brake and Jog functions not working	<ul style="list-style-type: none"> - These features are only available with in-line installation. If the MCD 500 is installed inside delta, these features will not operate.
A reset does not occur after an Auto-Reset, when using a remote 2-wire control.	<ul style="list-style-type: none"> - The remote 2-wire start signal must be removed and reapplied for a re-start.
Remote start/stop command is overriding Auto Start/Stop settings when using remote 2-wire control.	<ul style="list-style-type: none"> - Auto Start/Stop function should only be used in HAND ON mode or in tandem with HAND OFF mode, 3 and 4-wire control.
After selecting AAC the motor used an ordinary start and/or the second start was different to the first.	<ul style="list-style-type: none"> - The first AAC start is current limit so that the starter can learn from the motor characteristics. Subsequent starts use AAC.
Non-resettable THERMISTOR CCT trip, when there is a link between Thermistor input 05, 06 or when the motor thermistor connected between 05, 06 is permanently removed.	<ul style="list-style-type: none"> - The thermistor input is enabled once a link is fitted and short circuit protection has activated. <p>Remove the link then load the default parameter set. This will disable the thermistor input and clear the trip.</p> <p>Place a 1k2 Ω resistor across the thermistor input.</p> <p>Turn thermistor protection to 'Log only' (Par. 16-9).</p>
Parameter settings cannot be stored.	<ul style="list-style-type: none"> - Make sure you are saving the new value by pressing the OK button after adjusting a parameter setting. If you press BACK, the change will not be saved. - Check that the adjustment lock (Par. 15-2) is set to Read/Write. If the adjustment lock is on, settings can be viewed but not changed. You need to know the security access code to change the adjustment lock setting. - The EEPROM may be faulty on the Main Control PCB. A faulty EEPROM will also trip the soft starter, and the LCP will display the message <i>Par. Out of Range</i>. Contact your local supplier for advice.

10 Specifications

Supply

Mains voltage (L1, L2, L3)	
MCD5-xxxx-T5	200 VAC - 525 VAC ($\pm 10\%$)
MCD5-xxxx-T7	380 VAC - 600 VAC ($\pm 10\%$) (inside delta connection)
MCD5-xxxx-T7	380 VAC - 690 VAC ($\pm 10\%$) (earthed star supply system only)
Control voltage (A4, A5, A6)	
CV1 (A5, A6)	24 VAC/VDC ($\pm 20\%$)
CV2 (A5, A6)	110~120 VAC (+ 10% / - 15%)
CV2 (A4, A6)	220~240 VAC (+ 10% / - 15%)
Current consumption (maximum)	
CV1	2.8 A
CV2 (110 - 120 VAC)	1 A
CV2 (220 - 240 VAC)	500 mA
Mains frequency	50/60 Hz ($\pm 10\%$)
Rated insulation voltage to earth	600 VAC
Rated impulse withstand voltage	4 kV
Form designation	Bypassed or continuous, semiconductor motor starter form 1

Short circuit capability

Coordination with semiconductor fuses	Type 2
Coordination with HRC fuses	Type 1
MCD5-0021B to MCD5-0215B	prospective current 65 kA
MCD5-0245C to MCD5-0927B	prospective current 85 kA
MCD5-1200C to MCD5-1600C	prospective current 100 kA

Electromagnetic capability (compliant with EU Directive 89/336/EEC)

EMC Emissions	IEC 60947-4-2 Class B and Lloyds Marine No 1 Specification
EMC Immunity	IEC 60947-4-2

Inputs

Input Rating	Active 24 VDC, 8 mA approx
Start (15, 16)	Normally open
Stop (17, 18)	Normally closed
Reset (25, 18)	Normally closed
Programmable input (11, 16)	Normally open
Motor thermistor (05, 06)	Trip >3.6 k Ω , reset <1.6k Ω

Outputs

Relay Outputs	10A @ 250 VAC resistive, 5A @ 250 VAC AC15 pf 0.3
Programmable Outputs	
Relay A (13, 14)	Normally open
Relay B (21, 22, 24)	Changeover
Relay C (33, 34)	Normally open
Analog Output (07, 08)	0-20 mA or 4-20 mA (selectable)
Maximum load	600 Ω (12 VDC @ 20 mA)
Accuracy	$\pm 5\%$
24 VDC Output (16, 08) Maximum load	200 mA
Accuracy	$\pm 10\%$

Environmental

Protection	
MCD5-0021B - MCD5-0105B	IP20 & NEMA, UL Indoor Type 1
MCD5-0131B - MCD5-1600C	IP00, UL Indoor Open Type
Operating temperature	-10° C to 60° C, above 40° C with derating

Storage temperature	- 25° C to + 60° C
Operating Altitude	0 - 1000 m, above 1000 m with derating
Humidity	5% to 95% Relative Humidity
Pollution degree	Pollution Degree 3
Heat Dissipation	
During start	4.5 watts per ampere
During run	
MCD5-0021B - MCD5-0053B	= 39 watts approx
MCD5-0068B - MCD5-0105B	= 51 watts approx
MCD5-0131B - MCD5-0215B	= 120 watts approx
MCD5-0245C - MCD5-0927C	4.5 watts per ampere approx
MCD5-1200C - MCD5-1600C	4.5 watts per ampere approx
Certification	
C✓	IEC 60947-4-2
UL/ C-UL	UL 508
CE	IEC 60947-4-2
CCC	GB 14048-6
Marine	
(MCD5-0021B - MCD5-0215B only)	Lloyds Marine No 1 Specification
RoHS	Compliant with EU Directive 2002/95/EC

10.1 Accessories

10.1.1 Communication Modules

MCD 500 soft starters support network communication using the Profibus, DeviceNet and Modbus RTU protocols, via an easy-to-install communications module. The communications module plugs directly onto the side of the starter.

- 175G9000 Modbus Module
- 175G9001 Profibus Module
- 175G9002 DeviceNet Module
- 175G9009 MCD USB Module

10.1.2 PC Software

MCD PC Software can be used in conjunction with a communications module to provide the following functionality for networks of up to 99 soft starters.

Feature	MCD-201	MCD-202	MCD-3000	MCD500
Operational control (Start, Stop, Reset, Quick Stop)	•	•	•	•
Starter status monitoring (Ready, Starting, Running, Stopping, Tripped)	•	•	•	•
Performance monitoring (motor current, motor temperature)		•	•	•
Upload parameter settings			•	•
Download parameter settings			•	•

The PC software available from Danfoss's website is:

- WinMaster: VLT® Soft Starter software for control, configuration and management
- MCT10: VLT® software for configuration and management.

10.1.3 Finger Guard Kit

Finger guards may be specified for personnel safety and can be used on MCD 500 soft starter models 0131B - 1600C. Finger guards fit over the soft starter terminals to prevent accidental contact with live terminals. Finger guards provide IP20 protection.

- MCD5-0131B ~MCD5-0215B: 175G5662
- MCD5-245C: 175G5663
- MCD5-0360C ~MCD5-0927C: 175G5664
- MCD5-1200C ~MCD5-1600C: 175G5665

11 Bus Bar Adjustment Procedure (MCD5-0360C - MCD5-1600C)

NOTE

Many electronic components are sensitive to static electricity. Voltages so low that they cannot be felt, seen or heard, can reduce the life, affect performance, or completely destroy sensitive electronic components. When performing service, proper ESD equipment should be used to prevent possible damage from occurring.

All units are manufactured with input and output bus bars at the bottom of the unit as standard. The input and/or output bus bars can be moved to the top of the unit if required.

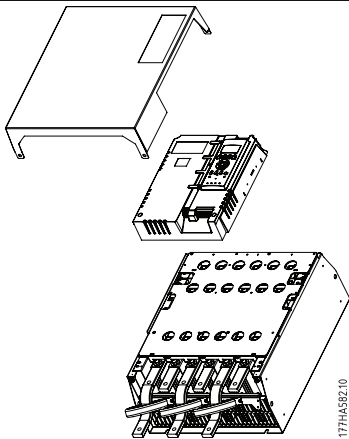

1. Remove all wiring and links from the soft starter before dismantling the unit.
2. Remove the unit cover (4 screws).
3. Unscrew the main plastic and fold away from the starter (4 screws).
4. Unplug the keypad loom from CON 1 (see note).
5. label each SCR firing loom with the number of the corresponding terminal on the main control PCB, then unplug the looms.
6. Unplug the thermistor, fan and CT wires from the main control PCB.

NOTE

Remove the main plastic slowly to avoid damaging the keypad wiring loom which runs between the main plastic and the backplane PCB.

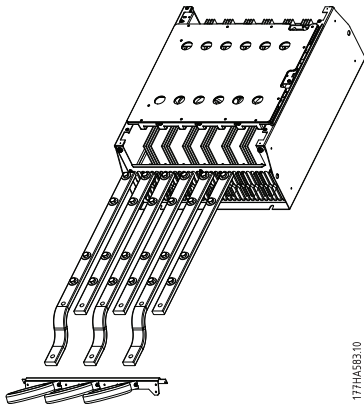

1. Unscrew and remove the magnetic bypass plates (models MCD5-0620C to MCD5-1600c ONLY).
2. Remove the CT assembly (three screws).
3. Identify which bus bars are to be moved. Remove the bolts holding these bus bars in place then slide the bus bars out through the bottom of the starter (four bolts per bus bar).

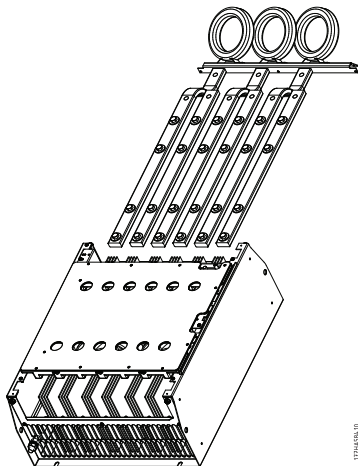

1. Slide the bus bars in through the top of the starter. For input bus bars, the short curved end should be outside the starter. For output bus bars, the unthreaded hole should be outside the starter.
2. Replace the dome washers with the flat face towards the bus bar, then tighten the bolts holding the bus bars in place to 20 Nm.
3. Place the CT assembly over the input bus bars and screw the assembly to the body of the starter (see note).
4. Run all wiring to the side of the starter and secure with cable ties.

NOTE

If moving the input bars, the CTs must also be reconfigured.

1. Label the CTs L1, L2 and L3 (L1 is leftmost when working from the front of the starter). Remove the cable ties and unscrew the CTs from the bracket.
2. Move the CT bracket to the top of the starter. Position the CTs for the correct phases, then screw the CTs to the bracket. For models MCD5-0360C - MCD5-0930, the CTs must be placed on an angle (the left hand legs of each CT will be on the top row of holes and the right hand legs will be on the bottom tabs).



www.danfoss.com/drives

Danfoss can accept no responsibility for possible errors in catalogues, brochures and other printed material. Danfoss reserves the right to alter its products without notice. This also applies to products already on order provided that such alterations can be made without subsequential changes being necessary in specifications already agreed. All trademarks in this material are property of the respective companies. Danfoss and the Danfoss logotype are trademarks of Danfoss A/S. All rights reserved.

